

# MDS-JA555ES

## SERVICE MANUAL

**Self Diagnosis**  
Supported model

*US Model  
Canadian Model  
AEP Model  
UK Model*



Photo : GOLD

U.S. and foreign patents licensed from Dolby Laboratories Licensing Corporation.

|                                    |              |
|------------------------------------|--------------|
| Model Name Using Similar Mechanism | MDS-JA20ES   |
| MD Mechanism Type                  | MDM-6A       |
| Base Unit Type                     | MBU-5C       |
| Optical Pick-up Type               | KMS-260B/J1N |

### SPECIFICATIONS

|                        |   |
|------------------------|---|
| System                 | MiniDisc digital audio system   |
| Disc                   | MiniDisc  |
| Laser                  | Semiconductor laser ( $\lambda=780$ nm)<br>Emission duration : continuous   |
| Laser output           | Less than 44.6 $\mu$ W*<br>* This output is the value measured at a distance of 200 mm from the objective lens surface on the Optical Pick-up Block with 7 mm aperture. |
| Laser diode properties | Material: GaAlAs  |
| Revolutions (CLV)      | 400 rpm to 900 rpm  |
| Error correction       | ACIRC (Advanced Cross Interleave Reed Solomon Code)   |
| Sampling frequency     | 44.1 kHz  |
| Coding                 | ATRAC (Adaptive TRansform Acoustic Coding)  |
| Modulation system      | EFM (Eight-to-Fourteen Modulation)  |
| Number of channels     | 2 stereo channels   |
| Frequency response     | 5 Hz to 20,000 Hz $\pm$ 0.3 dB  |
| Signal-to-noise ratio  | Over 105 dB during playback   |
| Wow and flutter        | Below measurable limit  |

#### Inputs

|                    | Jack type                     | Input impedance            | Rated input        | Minimum input |
|--------------------|-------------------------------|----------------------------|--------------------|---------------|
| LINE (ANALOG) IN   | Phono jacks                   | 47 k $\Omega$              | 500 mVrms          | 125 mVrms     |
| DIGITAL IN OPT1    | Square optical connector jack | Optical wave length 660 nm | —                  | —             |
| DIGITAL IN OPT2    | Square optical connector jack | Optical wave length 660 nm | —                  | —             |
| DIGITAL IN COAXIAL | Phono jack                    | 75 $\Omega$                | 0.5 Vp-p $\pm$ 20% | —             |

— Continued on next page —

MINIDISC DECK



**SONY**<sup>®</sup>

## SAFETY CHECK-OUT

After correcting the original service problem, perform the following safety checks before releasing the set to the customer: Check the antenna terminals, metal trim, “metallized” knobs, screws, and all other exposed metal parts for AC leakage. Check leakage as described below.

### LEAKAGE

The AC leakage from any exposed metal part to earth ground and from all exposed metal parts to any exposed metal part having a return to chassis, must not exceed 0.5 mA (500 microamperes). Leakage current can be measured by any one of three methods.

1. A commercial leakage tester, such as the Simpson 229 or RCA WT-540A. Follow the manufacturers’ instructions to use these instruments.
2. A battery-operated AC milliammeter. The Data Precision 245 digital multimeter is suitable for this job.
3. Measuring the voltage drop across a resistor by means of a VOM or battery-operated AC voltmeter. The “limit” indication is 0.75 V, so analog meters must have an accurate low-voltage scale. The Simpson 250 and Sanwa SH-63Trd are examples of a passive VOM that is suitable. Nearly all battery operated digital multimeters that have a 2V AC range are suitable. (See Fig. A)

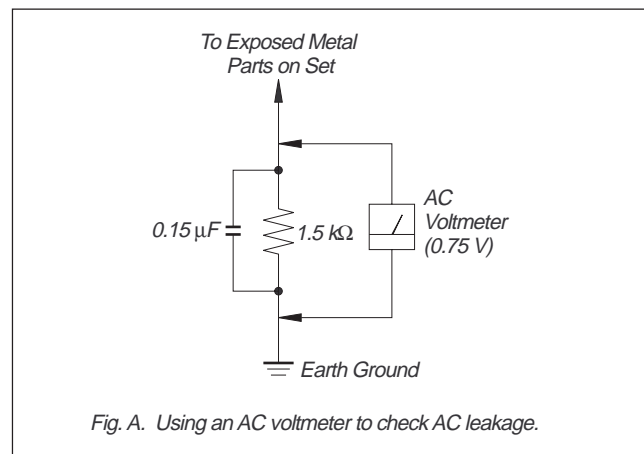

Fig. A. Using an AC voltmeter to check AC leakage.

### Output

|                     | Jack type                     | Rated output                   | Load impedance             |
|---------------------|-------------------------------|--------------------------------|----------------------------|
| PHONES              | Stereo phone jacks            | 28 mW                          | 32 Ω                       |
| LINE(ANALOG) OUT    | Phono jacks                   | 2 V <sub>rms</sub> (at 50 kΩ)  | Over 10 kΩ                 |
| DIGITAL OUT OPTICAL | Square optical connector jack | -18 dBm                        | Optical Wave length 660 nm |
| DIGITAL OUT COAXIAL | Phono jack                    | 0.5 V <sub>p-p</sub> (at 75 Ω) | 75 Ω                       |

### General

#### Power requirements

| Where purchased           | Power requirements       |
|---------------------------|--------------------------|
| Continental Europe and UK | 220V – 230V AC, 50/60 Hz |
| U.S.A. and Canada         | 120 V AC, 60 Hz          |

Power consumption 24 W

Dimensions (approx.)(w/h/d) incl. projecting parts and controls  
430 × 125.5 × 375.5 mm  
(17 × 5 × 13 3/4 in.)

Mass (approx.) 15.3 kg (33 lbs 11 oz)

### Supplied accessories

- Audio connecting cords (2)
- Remote commander (remote) RM-D34M (1)
- R6 (size-AA) batteries (2)

Design and specifications are subject to change without notice.

### CAUTION

Danger of explosion if battery is incorrectly replaced. Replace only with the same or equivalent type recommended by the equipment manufacturer. Discard used batteries according to manufacture’s instructions.

### ADVARSEL!

Lithiumbatteri - Eksplosionsfare ved fejlagtig håndtering. Udskiftning må kun ske med batteri af samme fabrikat og type. Levér det brugte batteri tilbage til leverandøren.

### ADVARSEL

Eksplosjonsfare ved feilaktig skifte av batteri. Benytt samme batteritype eller en tilsvarende type anbefalt av apparatfabrikanten. Brukte batterier katterier kasseres i henhold til fabrikantens

### VARNIG

Explosionsfara vid felaktigt batteribyte. Använd samma batterityp eller en likvärdig typ som rekommenderas av apparattillverkaren. Kassera använt batteri enligt gällande föreskrifter.

### VAROITUS

Parist voi räjähtää, jos se on virheellisesti asennettu. Vaihda paristo ainoastaan laitevalmistajan suosittelemaan tyyppiin. Hävitä käytetty paristo valmistajan ohjeiden mukaisesti.

### SAFETY-RELATED COMPONENT WARNING!!

COMPONENTS IDENTIFIED BY MARK  $\triangle$  OR DOTTED LINE WITH MARK  $\triangle$  ON THE SCHEMATIC DIAGRAMS AND IN THE PARTS LIST ARE CRITICAL TO SAFE OPERATION. REPLACE THESE COMPONENTS WITH SONY PARTS WHOSE PART NUMBERS APPEAR AS SHOWN IN THIS MANUAL OR IN SUPPLEMENTS PUBLISHED BY SONY.

### ATTENTION AU COMPOSANT AYANT RAPPORT À LA SÉCURITÉ!

LES COMPOSANTS IDENTIFIÉS PAR UNE MARQUE  $\triangle$  SUR LES DIAGRAMMES SCHÉMATIQUES ET LA LISTE DES PIÈCES SONT CRITIQUES POUR LA SÉCURITÉ DE FONCTIONNEMENT. NE REMPLACER CES COMPOSANTS QUE PAR DES PIÈCES SONY DONT LES NUMÉROS SONT DONNÉS DANS CE MANUEL OU DANS LES SUPPLÉMENTS PUBLIÉS PAR SONY.

Laser component in this product is capable of emitting radiation exceeding the limit for Class 1.



This appliance is classified as a CLASS 1 LASER product. The CLASS 1 LASER PRODUCT MARKING is located on the rear exterior.

The following caution label is located inside the unit.

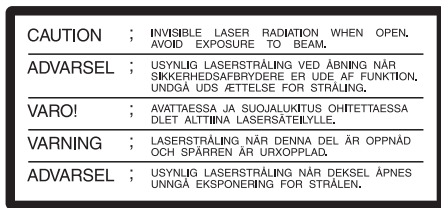

**CAUTION**  
Use of controls or adjustments or performance of procedures other than those specified herein may result in hazardous radiation exposure.

**Notes on chip component replacement**

- Never reuse a disconnected chip component.
- Notice that the minus side of a tantalum capacitor may be damaged by heat.

**Flexible Circuit Board Repairing**

- Keep the temperature of soldering iron around 270°C during repairing.
- Do not touch the soldering iron on the same conductor of the circuit board (within 3 times).
- Be careful not to apply force on the conductor when soldering or unsoldering.

**MODEL IDENTIFICATION — BACK PANEL —**

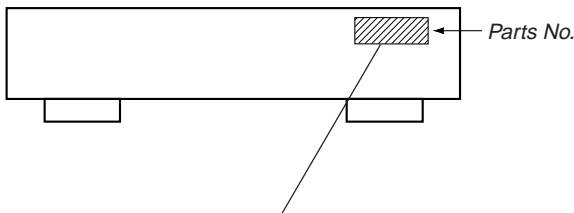

- 4-220-300-1 □ : AEP, UK model
- 4-220-300-2 □ : US model
- 4-220-300-3 □ : Canadian model

**TABLE OF CONTENTS**

**1. SERVICING NOTE** ..... 6

**2. GENERAL** ..... 12

**3. DISASSEMBLY**

3-1. Case ..... 14

3-2. Loading Panel ..... 14

3-3. Front Panel Assembly ..... 15

3-4. MD Mechanism Deck ..... 15

3-5. Tray Assembly ..... 16

3-6. BU Holder Assembly ..... 17

3-7. Motor (Loading) Assembly (M10) ..... 17

3-8. Base Unit (MBU-5C) ..... 18

3-9. BD Board ..... 18

3-10. Over Light Head (HP901) ..... 19

3-11. Mini Disc Device (KMS-260B/JN) ..... 19

**4. TEST MODE** ..... 20

**5. ELECTRICAL ADJUSTMENTS** ..... 25

**6. DIAGRAMS**

6-1. Block Diagrams

BD Section ..... 34

MAIN Section ..... 35

Display/Power Supply Section ..... 36

6-2. Circuit Boards Location ..... 37

6-3. Printed Wiring Board BD Section ..... 38

6-4. Schematic Diagram BD (2/1) Section ..... 39

6-5. Schematic Diagram BD (2/1) Section ..... 40

6-6. Schematic Diagram BD Switch Section ..... 41

6-7. Printed Wiring Board BD Switch Section ..... 41

6-8. Printed Wiring Board AD Section ..... 42

6-9. Schematic Diagram AD (2/1) Section ..... 43

6-10. Schematic Diagram AD (2/1) Section ..... 44

6-11. Schematic Diagram DA (2/1) Section ..... 45

6-12. Printed Wiring Board DA Section ..... 48

6-13. Schematic Diagram DA (2/1) Section ..... 47

6-14. Printed Wiring Board Digital Section ..... 48

6-15. Schematic Diagram Digital Section ..... 50

6-16. Printed Wiring Board AC Section ..... 51

6-17. Schematic Diagram Power Section ..... 52

6-18. Printed Wiring Board Power Section ..... 53

6-19. Printed Wiring Board Panel Section ..... 54

6-20. Schematic Diagram Panel Section ..... 55

6-21. IC Block Diagrams ..... 57

6-22. IC Pin Functions ..... 62

**7. EXPLODED VIEWS**

7-1. Upper Case Assembly ..... 71

7-2. Front Panel Assembly ..... 72

7-3. Chassis Assembly ..... 73

7-4. Mechanism Deck Assembly-1 (MDM-6A) ..... 74

7-5. Mechanism Deck Assembly-2 (MDM-6A) ..... 75

7-6. Base Unit (MBU-5C) ..... 76

**8. ELECTRICAL PARTS LIST** ..... 77

## SELF-DIAGNOSIS FUNCTION

The self-diagnosis function consists of the error codes for users and those for service engineers. The error codes for users appear automatically when an error occurs. The error codes for service engineers can be accessed by entering the test mode during servicing and by viewing the error history display. The error codes for users are shown below that are extracted from Operation Manual. For the error codes for service engineers, refer to the subsequent paragraph “How to Operate the Self-diagnosis Function (Error History Display Mode)”.

### Self-Diagnosis Function

The deck has a self-diagnosis display. This function shows a three-digit display (a combination of a letter and figures) and the corresponding message alternately, so you can check the deck's condition.

If such a display appears, check the following table in order to resolve the problem.

Should any problem persist, consult your nearest Sony dealer.

Self-diagnosis display

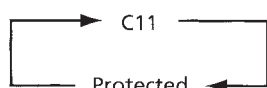



| Three-digit display/Message | Cause/Remedy  |
|-----------------------------|---|
| C11/Protected               | The inserted MD is record-protected.<br>➔ Take out the MD, and close the record-protect tab (page 11).  |
| C13/REC Error               | The recording was not made properly.<br>➔ Set the deck in a stable place, and repeat the recording procedure.<br><br>The inserted MD is dirty (with smudges, fingerprints, etc.), scratched, or not up to standards.<br>➔ Replace the disc, and repeat the recording procedure.   |
| C13/Disc Error              | The deck could not read the TOC of the MD properly.<br>➔ Take out the MD, and insert it again.  |
| C14/Disc Error              | The deck could not read the TOC of the MD properly.<br>➔ Insert another disc.<br>➔ If possible, erase all tracks on the MD using the All Erase Function on page 36.   |
| C71/Din Unlock              | A moment's lighting is due to the signals of the digital program being recorded. This does not affect the recorded material.<br><br>While recording from a digital component connected through the digital input connector, the digital connecting cable was unplugged or the digital component turned off.<br>➔ Connect the cable or turn the digital component back on. |

#### How to Operate Self-diagnosis Function (Error History Display Mode)

Note: The self-diagnosis function is performed using the “error history display mode” using the test mode. The following procedure describes only the minimum required operating procedure to enter the error history mode. Therefore be careful not to enter any other modes by mistake. If you have entered any other modes by mistake, press the **[MENU/NO]** button and exit the mode.

1. While pressing the **[◀◀AMS▶▶]** knob and the **[■]** button at the same time, connect the AC power plug to the wall outlet, then remove your hands from the **[◀◀AMS▶▶]** knob and **[■]** button at the same time. When the MDS-JA555ES enters the test mode, the message “[Check]” appears and the STANDBY, PITCH CONTROL, and FILTER LEDs turn on.
2. Rotate the **[◀◀AMS▶▶]** knob until the message “Service” appears. Then press the **[YES]** button.
3. Rotate the **[◀◀AMS▶▶]** knob until the message “ERR DP MODE” appears.
4. Press the **[YES]** button to enter the error history mode and the message “total rec” appears.
5. Select the desired item to display or to execute using the **[◀◀AMS▶▶]** knob.
6. Press the **[◀◀AMS▶▶]** knob to display or execute the selected item.
7. Pressing the **[◀◀AMS▶▶]** knob again returns to the display of step 4.
8. To exit the error history mode, press the **[MENU/NO]** button. The message “ERR DP MODE” appears to exit the error history mode.
9. To exit the test mode, press the **[REPEAT]** button. The test mode display disappears and the PITCH CONTROL and FILTER LEDs are turned off. The MDS-JA555ES enters the standby state exiting the test mode. While pressing the **[I/⏻]** button, turn on the main power. The message “Initialize” flashes and the MDS-JA555ES is initialized.

## [Displaying Contents of the Error History]

| Display on screen | Contents of error history   |
|-------------------|---|
| total rec         | Displays the recording time.<br>The display appears in “r:00000000 h”. This is the accumulated time when the laser is in the “high power” operation. This is about 1/4 of the actual recording time. The time is shown in the range of 0h to 65535h in hexadecimal number.  |
| total play        | Displays the playback time.<br>The display appears in “p:00000000 h”. This is the accumulated time of actual playback in which pause time is not counted. The time is shown in the range of 0h to 65535h in hexadecimal number.   |
| retry err         | Displays the accumulated count of record retry errors and playback retry errors.<br>The display appears in “r:00 p:00”. “r” indicates the record retry error count, and “p” indicates the playback retry error count. The retry count is shown in the range of 00 to FF in hexadecimal number.  |
| total err         | Displays the total error count.<br>The message “total:00” appears. The count is shown in the range of 00 to FF in hexadecimal number.   |
| err history       | Displays the error contents from the latest error to the last ten errors.<br>“0:0 E@@” appears. The history number is shown in 0. The smaller number means the newer history. (00 is the newest error.) The error code is indicated by @@. Refer to the following table for the contents of the error codes. The error histories can be switched by rotating the  knob.   |
| er refresh        | This mode is used to delete the histories of “retry err”, “total err”, and “err history”.<br>Before returning the repaired product to the customer, perform this operation to delete the past error history. To delete the history, press the  knob and press the YES button after “er refresh?” appears. “Complete!” appears for a moment and returns to the ERR DP MODE.<br>When this mode is executed, be sure to check the following. <ul style="list-style-type: none"> <li>• The data have been deleted.</li> <li>• Perform recording and playback. Check that the mechanism operates normally.</li> </ul>  |
| tm refresh        | This mode is used to delete the histories of “total rec” and “total play”. These histories are used as reference when replacing the optical pick-up.<br>When the optical pick-up is replaced, perform this operation to delete the histories. Press the  knob. After “tm refresh?” appears, press the <b>YES</b> button to delete the histories. “Complete!” appears for a moment and returns to the ERR DP MODE.<br>When this mode is executed, be sure to check the following. <ul style="list-style-type: none"> <li>• The data have been deleted.</li> <li>• Perform recording and playback and check that the mechanism operates normally.</li> </ul> |

### Error code table

| Error code | Error contents                                   | Error code | Error contents                     |
|------------|--|------------|------------------------------------|
| E00        | No errors  | E05        | Out of FOK                         |
| E01        | Disc error Cannot read PTOC<br>(Disc is ejected) | E06        | Focus does not lock (Out of servo) |
|            |  | E07        | Record retry                       |
| E02        | Disc error UTOC error<br>(Disc is not ejected)   | E08        | Record retry error                 |
|            |  | E09        | Playback retry error               |
| E03        | Loading error                                    |            |                                    |
| E04        | Cannot read the address (Out of servo)           | E0A        | Playback retry error (C2 error)    |

# SECTION 1 SERVICING NOTE

## HOW TO OPEN THE DISC TRAY WHEN POWER SWITCH IS TURNED OFF, AND LASER POWER CHECK

- ① Remove the 16 screws (BVTT3 x 8) from the bottom plate. (Refer to Section 3 “Disassembly” Loading panel.) (page 14)
- ② Remove the bottom plate.
- ③ Rotate the pulley gear in the direction of the arrow **(A)** and open the tray in the direction of the arrow **(B)**.
- ④ When checking the laser power, remove beforehand the loading panel by removing the two screws (M2.6) and sliding aside the loading panel because the cable of the laser power meter can be pinched by the loading panel. (Refer to Section 3 “Disassembly” Loading panel.) (page 14)

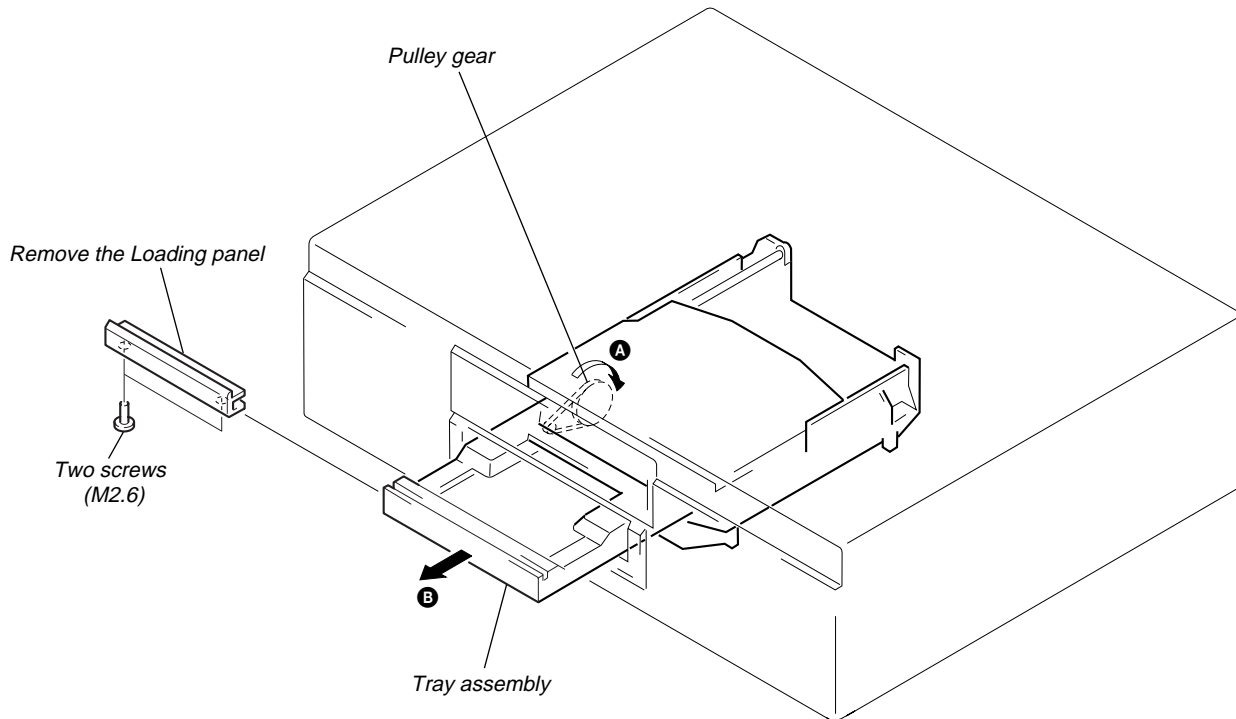

### Forced Reset

Use this function when the MDS-JA555ES cannot be operated normally due to hung-up of the microprocessor.

It is recommended to use this function when you cannot exit the test mode or the retry-cause-display mode, or when the normal operation cannot be performed after the MDS-JA555ES is disassembled once then re-assembled.

**Procedure** : Remove the AC power plug from the wall outlet. Short-circuit pin-① and pin-③ of CN703 on the BT board with a pair of tweezers or the like, to discharge the back-up battery.

[BT board] (Conductor side)

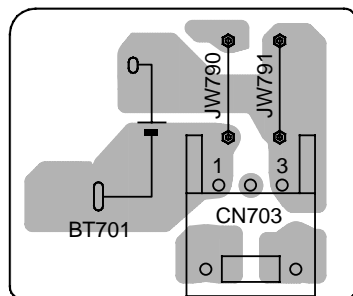

## [BD Board Waveform Check Tool]

Use of the exclusive tool (J-2501-149-A) is convenient to check the waveforms on the BD board.

- GND : Ground terminal
- I+3V : For measuring IOP (Checking deterioration of the optical pickup laser)
- IOP : For measuring IOP (Checking deterioration of the optical pickup laser)
- TEO : TRK error signal (traverse adjustment)
- VC : Reference level for when checking signals
- RF : RF signal (jitter check)

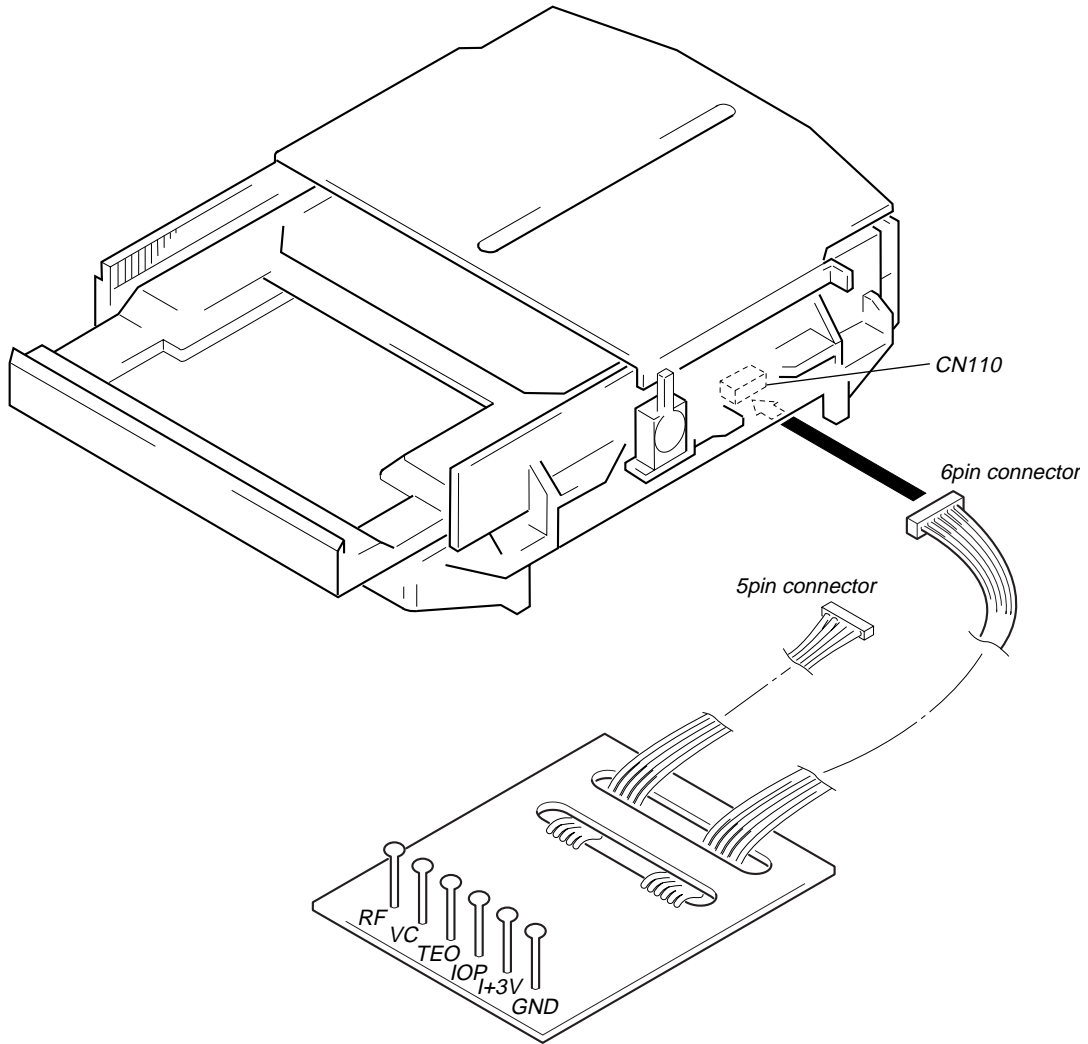



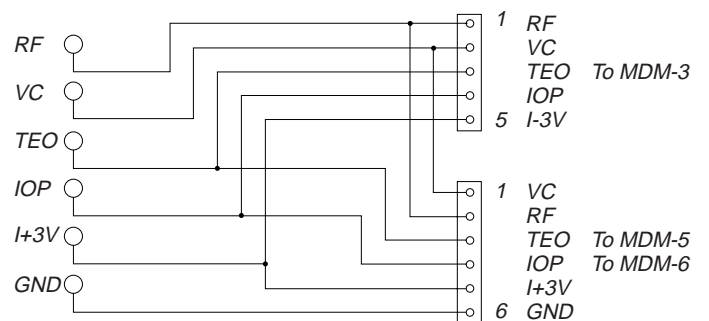









Schematic diagram of the connecting tools











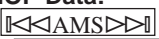

## [How to Record and Display the IOP Data When Replacing the Optical Pick-up and Non-volatile Memory (BD Board IC171)]

The IOP data that is indicated on the optical pick-up, can be saved in the non-volatile memory of the MDS-JA555ES. Saving the IOP data in the memory eliminates the needs to look at the printed value on the label that is attached on the surface of optical pick-up, and enables to view the IOP data on display. When the optical pick-up is replaced or when the non-volatile memory (IC171 on BD board) is replaced, save the IOP value that is printed on the label on the surface of optical pick-up by the following procedure.

### How to Record the IOP Data:

1. While pressing the  knob and the  button at the same time, connect the AC power plug to the wall outlet, then remove your hands from the  knob and  button at the same time. When the MDS-JA555ES enters the test mode, the message “[Check]” appears.
2. Rotate the  knob until the message “Service” appears. Then press the  button.
3. Rotate the  knob until the message “Iop Write” (C28) appears. Then press the  button.
4. “Ref=@@.@” (@ is arbitrary number) appears and the values that can be changed as desired flash.
5. Input the IOP value that is printed on the optical pick-up.  
Selection of alphanumeric characters : Rotate the  knob.  
Selection of digit : Press the  knob.
6. Press the  button. Then display changes to “Measu=@@@.@” (@ is arbitrary number).
7. The value that is shown step 6, is the result adjustment and should not be saved. So leave the value of step 6 as it is, and press the  button.
8. The message “Complete!” appears for a moment, and the value is saved in the non-volatile memory. The message “Iop Write” appears.
9. Upon completion of data saving, press the  button.

### How to Display the IOP Data:

1. While pressing the  knob and the  button at the same time, connect the AC power plug to the wall outlet, then remove your hands from the  knob and  button at the same time. When the MDS-JA555ES enters the test mode, the message “[Check]” appears.
2. Rotate the  knob until the message “Service” appears. Then press the  button.
3. Rotate the  knob until the message “Iop Write” (C28) appears. Then press the  button.
4. The message “@@.@/##.#” appears. The contents that are saved in the non-volatile memory appear.  
@@.@ : The IOP value that is printed on optical pick-up  
##.# : The IOP value after adjustment
5. To exit the data display, press the  knob or the  button to show the message “Iop Read”. Then press the  button.



### [Checks before Part Replacement and Adjustment]

Cause of faulty can be approximately located by performing the following checks before starting the repair work. Refer to Section “5. Electrical Adjustment” the check procedure.

|   | Judgment criterion(NG when the measurement value is out of the specification value)   | Remedial measure in case of NG  |
|---|---|---|
| Laser power check<br>(Refer to section 5-6-2, page 27.)                           | <ul style="list-style-type: none"> <li>0.9 mW power<br/>Specification value: 0.84 to 0.92 mW</li> <li>7.0 mW power<br/>Specification value: 6.8 to 7.2 mW</li> </ul>  | <ul style="list-style-type: none"> <li>Cleaning the optical pick-up</li> <li>Readjustment</li> <li>Replacing the optical pick-up</li> </ul>   |
|   | <ul style="list-style-type: none"> <li>Iop (when 7 mW)<br/>The Iop value that is shown on the optical pick-up: +/- 10 mA</li> </ul>   | <ul style="list-style-type: none"> <li>Replacing the optical pick-up</li> </ul>   |
| Traverse check<br>(Refer to section 5-6-3, page 28.)                              | <ul style="list-style-type: none"> <li>Traverse waveform<br/>Specification value: Offset 10% or less</li> </ul>   | <ul style="list-style-type: none"> <li>Replacing the optical pick-up</li> </ul>   |
| Focus bias check<br>(Refer to section 5-6-4, page 29.)                            | <ul style="list-style-type: none"> <li>Checking the error rate<br/>Specification value: All points of a, b, and c<br/>CI error 220 or less<br/>AD error 2 or less</li> </ul>  | <ul style="list-style-type: none"> <li>Replacing the optical pick-up</li> </ul>   |
| C PLAY check<br>(Refer to section 5-6-5, page 29.)                                | <ul style="list-style-type: none"> <li>Checking the error rate<br/>Specification value:<br/>a. When using the test disc (MDW-74/AU-1)<br/>CI error 80 or less<br/>AD error 2 or less<br/>b. When using the check disc (TDYS-1)<br/>CI error 50 or less</li> </ul> | <ul style="list-style-type: none"> <li>Replacing the optical pick-up</li> </ul>   |
| Self-recording/playback check<br>(REC/PLAY)<br>(Refer to section 5-6-6, page 29.) | <ul style="list-style-type: none"> <li>Checking the error rate in C PLAY<br/>Specification value:<br/>CI error 80 or less<br/>AD error 2 or less</li> </ul>   | In case of NG all the time: <ul style="list-style-type: none"> <li>Replacing the overwrite head</li> <li>Check disconnection of the circuits around the overwrite head</li> </ul>           |
|   |   | In case of intermittent NG: <ul style="list-style-type: none"> <li>Check deformation of overwrite head</li> <li>Check mechanism around the sled</li> </ul>                                  |
| Temperature compensation offset check<br>(Refer to section 5-6-1, page 27.)       | <ul style="list-style-type: none"> <li>NG when “T=@@(#)(NG” appears (@@ and ## are arbitrary numbers.)</li> </ul>   | <ul style="list-style-type: none"> <li>Check disconnection of the circuits around the D101 (BD board)</li> <li>Check signals around the IC101, IC121, CN102 and CN103 (BD board)</li> </ul> |

Note: The judgment criterion is shown for the purpose of judging if the performance is acceptable or not. This is not the specification value for adjustment. Use the specification value for adjustment when the MDS-JA555ES is going to be adjusted.

## [Retry Cause Display Mode]

- In this test mode, the retry causes of the MDS-JA555ES during record and stop modes can be displayed on the fluorescent display tube. This mode becomes the “track mode” during playback in which the track information is available. This mode is useful for locating the defective area of the MDS-JA555ES.
- The contents to be displayed are as follows.
  - During record and stop modes: Retry cause, number of retries, and number of retry errors
  - During playback mode: Information such as disc types under playing back, position of playback and copyright.
 Each information is displayed in hexadecimal number.

### Procedure:

- Load a recordable disc whose contents can be erased, into the MDS-JA555ES.
- Press the **MENU/NO** button. After the message “Edit Menu” appears on the fluorescent display tube, rotate the **◀◀AMS▶▶** knob until the message “All Erase ?” appears.
- Press the **YES** button. (Alternately the **◀◀AMS▶▶** knob can also be pressed.)
- The message “All Erase ???” appears on the fluorescent display tube. Then the numerals on the music calendar flash.
- Press the **YES** button, then the message “Complete !!” appears. Press the **■** button immediately, and wait for about 15 seconds while keeping pressing the button. (Alternately the **◀◀AMS▶▶** knob can be pressed instead of **YES** button.)
- When the characters “TOC” have disappeared from the fluorescent display tube, remove your hands from the **■** button.
- Press the **●REC** button to enter the record standby mode. Then press the **||** button to start recording.
- When you want to enter the “Track mode”, press the **▶** button to start playback.
- To exit the test mode, press the **I/O** button. The message “TOC” flashes, the MDS-JA555ES enters the standby mode and exits the test mode.

Fig. 1 Reading the Test Mode Display (During record and stop modes)

**RTs@@c##e\*\***

Display on the fluorescent display tube

@@ : Cause of retry  
 ## : Number of retries  
 \*\* : Number of retry errors

Fig. 2 Reading the Test Mode Display (During playback)

**@@ #####\* \$\$**

Display on the fluorescent display tube

@@ : Parts No. (Area name that is given on the TOC)  
 ## : Cluster address (physical address on the disc)  
 \*\* : Sector  
 \$\$ : Track mode (track information such as copyright information of each part, etc.)

### How to read the retry cause display:

|               | Higher Bits |    |    |    | Lower Bits |    |    |    |             |                           |  |
|---------------|-------------|----|----|----|------------|----|----|----|-------------|---------------------------|--|
| Hexadecimal   | 8           | 4  | 2  | 1  | 8          | 4  | 2  | 1  | Hexadecimal | Name of retry cause       | When 1   |
| Bit           | b7          | b6 | b5 | b4 | b3         | b2 | b1 | b0 |             |                           |  |
| Binary number | 0           | 0  | 0  | 0  | 0          | 0  | 0  | 1  | 01          | shock                     | When track jump (shock) is detected                              |
|               | 0           | 0  | 0  | 0  | 0          | 0  | 1  | 0  | 02          | ader5                     | When ADER is counted five times or more continuously             |
|               | 0           | 0  | 0  | 0  | 0          | 1  | 0  | 0  | 04          | Address is not continuous | When ADIP address is not continuous                              |
|               | 0           | 0  | 0  | 0  | 1          | 0  | 0  | 0  | 08          | DIN unlock                | Detects DIN unlock is detected                                   |
|               | 0           | 0  | 0  | 1  | 0          | 0  | 0  | 0  | 10          | FCS unlock                | When focus is unlocked   |
|               | 0           | 0  | 1  | 0  | 0          | 0  | 0  | 0  | 20          | IVR rec error             | When signal level of the ABCD signal exceeds the specified range |
|               | 0           | 1  | 0  | 0  | 0          | 0  | 0  | 0  | 40          | CLV unlock                | When CLV is unlocked   |
|               | 1           | 0  | 0  | 0  | 0          | 0  | 0  | 0  | 80          | Access fault              | When access operation is not performed normally                  |

**Reading the Display:**

Convert the hexadecimal display of each digit into binary display. If more than two causes, they will be added.

Example When 42 is displayed:

Higher bit: 4 = 0100 → b6

Lower bit: 2 = 0010 → b2

In this case, the retry cause is combined of “CLV unlock” and “ader5”.

Example When A2 is displayed:

Higher bit: A = 1010 → b7+b5

Lower bit: 2 = 0010 → b1

In this case, the retry cause is combined of “ACCESS default”, “IVRrec” and “ader5”.

The reading of the track mode display is as follows.

| Hexadecimal | Higher Bits |    |    |    | Lower Bits |    |    |    | Hexadecimal | Contents                         |                    |
|-------------|-------------|----|----|----|------------|----|----|----|-------------|----------------------------------|--------------------|
|             | 8           | 4  | 2  | 1  | 8          | 4  | 2  | 1  |             | When 0                           | When 1             |
| Bit         | b7          | b6 | b5 | b4 | b3         | b2 | b1 | b0 |             |                                  |                    |
| Binary      | 0           | 0  | 0  | 0  | 0          | 0  | 0  | 1  | 01          | Emphasis OFF                     | Emphasis OFF       |
|             | 0           | 0  | 0  | 0  | 0          | 0  | 1  | 0  | 02          | Monaural                         | Stereo             |
|             | 0           | 0  | 0  | 0  | 0          | 1  | 0  | 0  | 04          | 2-bit display, normally 01       |                    |
|             | 0           | 0  | 0  | 0  | 1          | 0  | 0  | 0  | 08          | 01: Normal audio, Other: Invalid |                    |
|             | 0           | 0  | 0  | 1  | 0          | 0  | 0  | 0  | 10          | Audio (normal)                   | Invalid            |
|             | 0           | 0  | 1  | 0  | 0          | 0  | 0  | 0  | 20          | Original                         | Digital copy       |
|             | 0           | 1  | 0  | 0  | 0          | 0  | 0  | 0  | 40          | Copyright exists                 | No copyright       |
|             | 1           | 0  | 0  | 0  | 0          | 0  | 0  | 0  | 80          | Writing is prohibited            | Writing is allowed |

**Reading the Display:**

Convert the hexadecimal display of each digit into binary display. The several causes are added and displayed.

Example When 84 is displayed:

Higher bit: 8 = 1000 → b7

Lower bit: 4 = 0100 → b2

This example shows that “Emphasis: OFF”, “Monaural”, “Original”, “Copyright exists” and “Writing is allowed” because b2 and b7 are 1 while all other bits are 0.

Example When 07 is displayed:

Higher bit: 0 = 0000 → all 0

Lower bit: 7 = 0111 → b0+b1+b2

This example shows that “Emphasis: ON”, “Stereo”, “Original”, “Copyright exists” and “Writing is prohibited” because b0, b1 and b2 are 1 while all other bits are 0.

Hexadecimal → Binary Conversion Table

| Hexadecimal | Binary | Hexadecimal | Binary |
|-------------|--------|-------------|--------|
| 0           | 0000   | 8           | 1000   |
| 1           | 0001   | 9           | 1001   |
| 2           | 0010   | A           | 1010   |
| 3           | 0011   | B           | 1011   |
| 4           | 0100   | C           | 1100   |
| 5           | 0101   | D           | 1101   |
| 6           | 0110   | E           | 1110   |
| 7           | 0111   | F           | 1111   |

## SECTION 2 GENERAL

### Front Panel

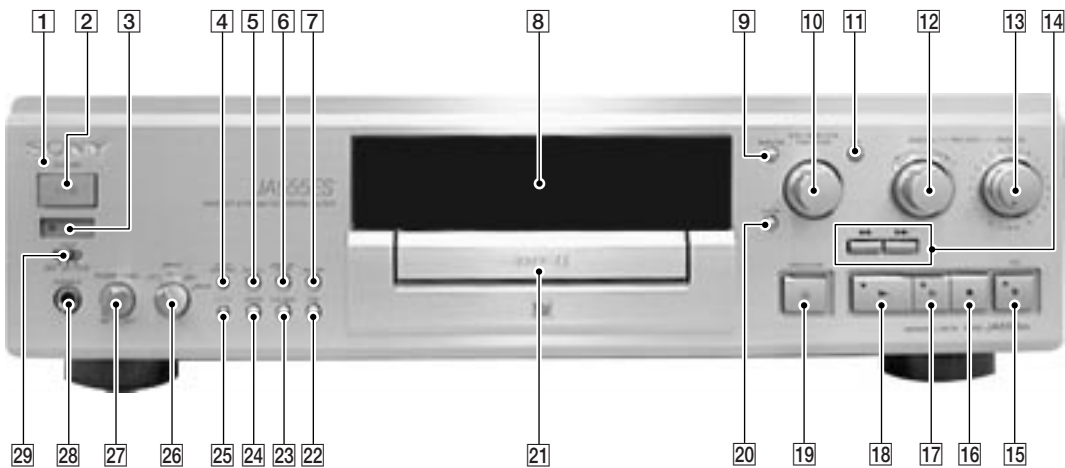

- |                                      |   |
|--------------------------------------|---|
| <b>1</b> SATNDBY indicator           | <b>16</b> ■ (STOP) button                 |
| <b>2</b> I/⏻ (POWER) button          | <b>17</b>    (PAUSE) button and indicator |
| <b>3</b> Remote sensor               | <b>18</b> ► (PLAY) button and indicator   |
| <b>4</b> PITCH CONTROL button        | <b>19</b> ≡ OPEN/CLOSE button             |
| <b>5</b> SCROLL button               | <b>20</b> CLEAR button                    |
| <b>6</b> DISPLAY/CHAR button         | <b>21</b> Disc Tray                       |
| <b>7</b> REPEAT button               | <b>22</b> TIME button                     |
| <b>8</b> Display window              | <b>23</b> PLAY MODE button                |
| <b>9</b> MENU/NO button              | <b>24</b> FADER button                    |
| <b>10</b> ⏮ AMS ⏭ knob               | <b>25</b> FILTER button                   |
| <b>11</b> YES button                 | <b>26</b> INPUT button                    |
| <b>12</b> DIGITAL REC LEVEL knob     | <b>27</b> PHONE LEVEL knob                |
| <b>13</b> ANALOG REC LEVEL knob      | <b>28</b> PHONE jack                      |
| <b>14</b> ◀▶ button                  | <b>29</b> TIMER knob                      |
| <b>15</b> ● REC button and indicator |   |

### Rear Panel

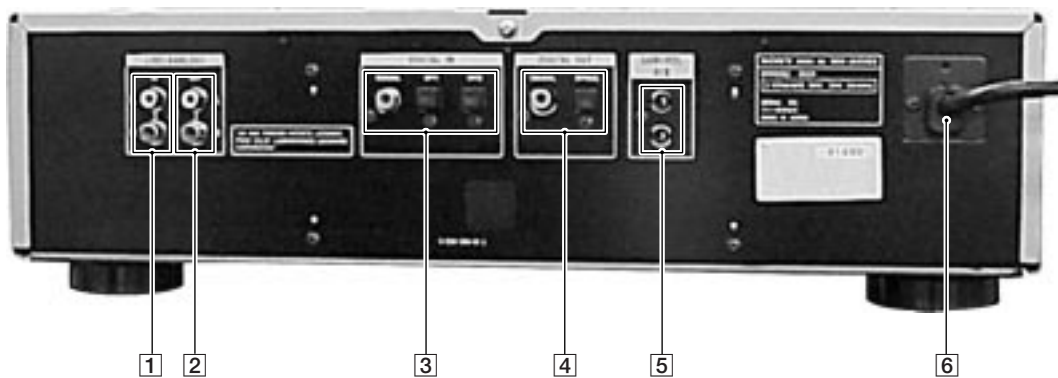

- |  |   |
|--|---|
| <b>1</b> LINE (ANALOG) IN jack               | <b>4</b> DIGITAL OUT (COAXIAL/OPT1/OPT2) jack |
| <b>2</b> LINE (ANALOG) OUT jack              | <b>5</b> CONTROL A1 II jack                   |
| <b>3</b> DIGITAL IN (COAXIAL/OPT1/OPT2) jack | <b>6</b> Power Supply cord                    |

## Setting the Clock

Once you set the MD deck's internal clock, the MD deck will automatically record the date and time of all recordings. When playing a track, you can display the date and time the track was recorded (see page 24). Time on this deck is displayed on a 12-hour clock (USA and Canadian models only) or a 24-hour clock (European model only).

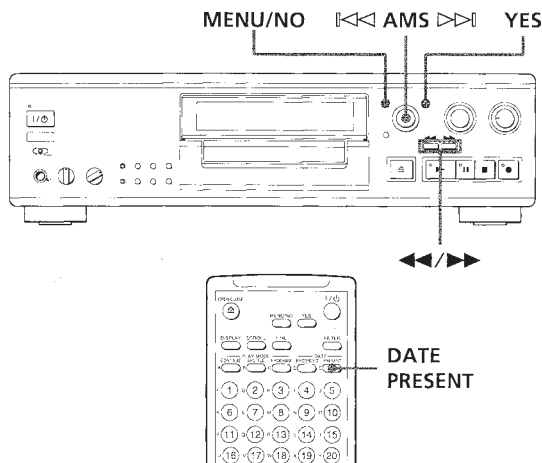

- 1 While the deck is stopped, press MENU/NO twice to display "Setup Menu".
- 2 Turn AMS to select "Setup 16", then press AMS or YES. The month (or day) indication starts flashing.

### USA and Canadian models

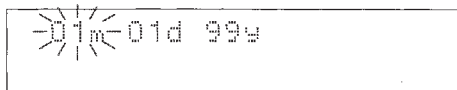

### European model

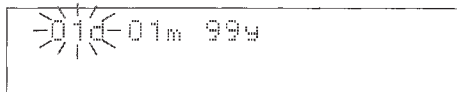

- 3 Turn AMS to enter the current month (or day), then press AMS. The month (or day) indication stops flashing, and the day (or month) indication starts flashing.

### USA and Canadian models

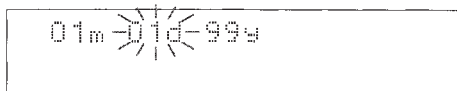

### European model

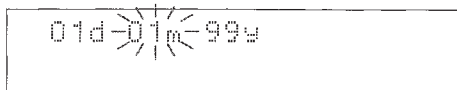

- 4 Repeat Step 3 to enter the month, day, year, hour, and minute.

### USA and Canadian models



### European model

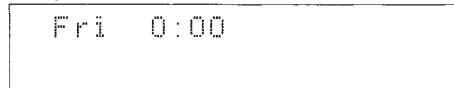

- 💡 **For precise time and date stamping of recordings**  
Reset the time at least once a week.

### Note

If the AC power cord is disconnected for a long time, the memorized clock settings will disappear and "Initialize" will flash in the display the next time you plug in and turn on the deck. If this happens, reset the clock.

## Displaying the current date and time

You can display the current date and time any time even when the deck is in standby status.

Press DATE PRESENT.

Each press of the button changes the display as follows:

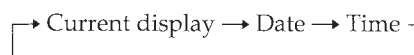

## Changing the clock setting(s)

- 1 Do steps 1 and 2 above.
- 2 Press AMS or ◀/▶ repeatedly until the setting you want to change flashes.
- 3 Turn AMS to change the setting, then press AMS or YES.
- 4 To complete the setting, press AMS or ◀/▶ repeatedly until all items stop flashing.

## SECTION 3 DISASSEMBLY

**Note :** Follow the disassembly procedure in the numerical order given.

### 3-1. CASE

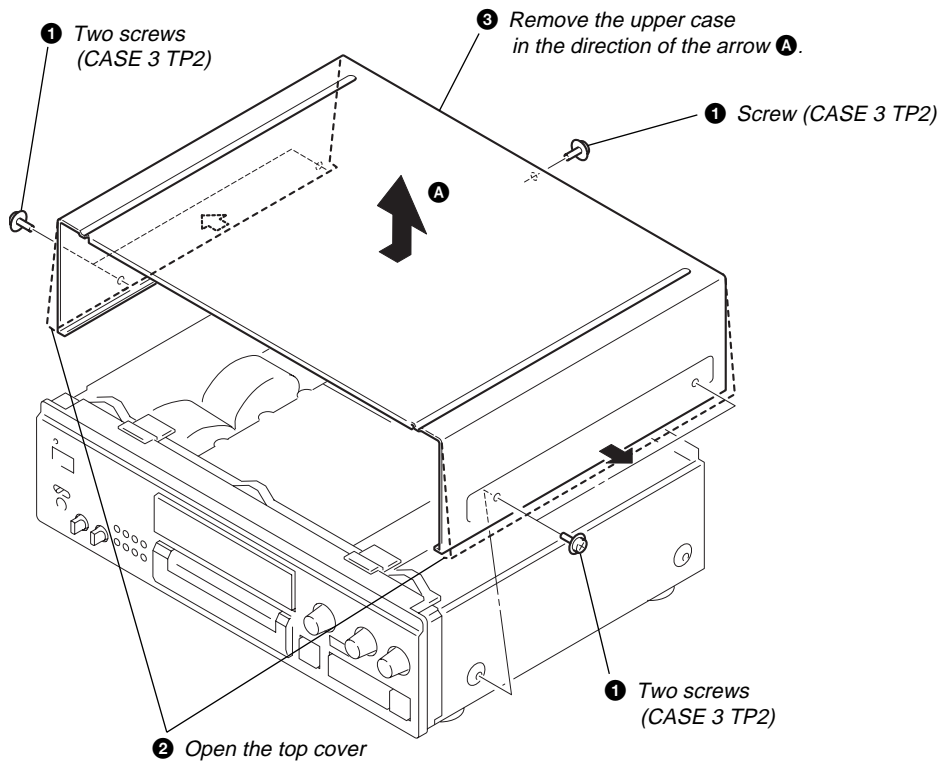

### 3-2. LOADING PANEL

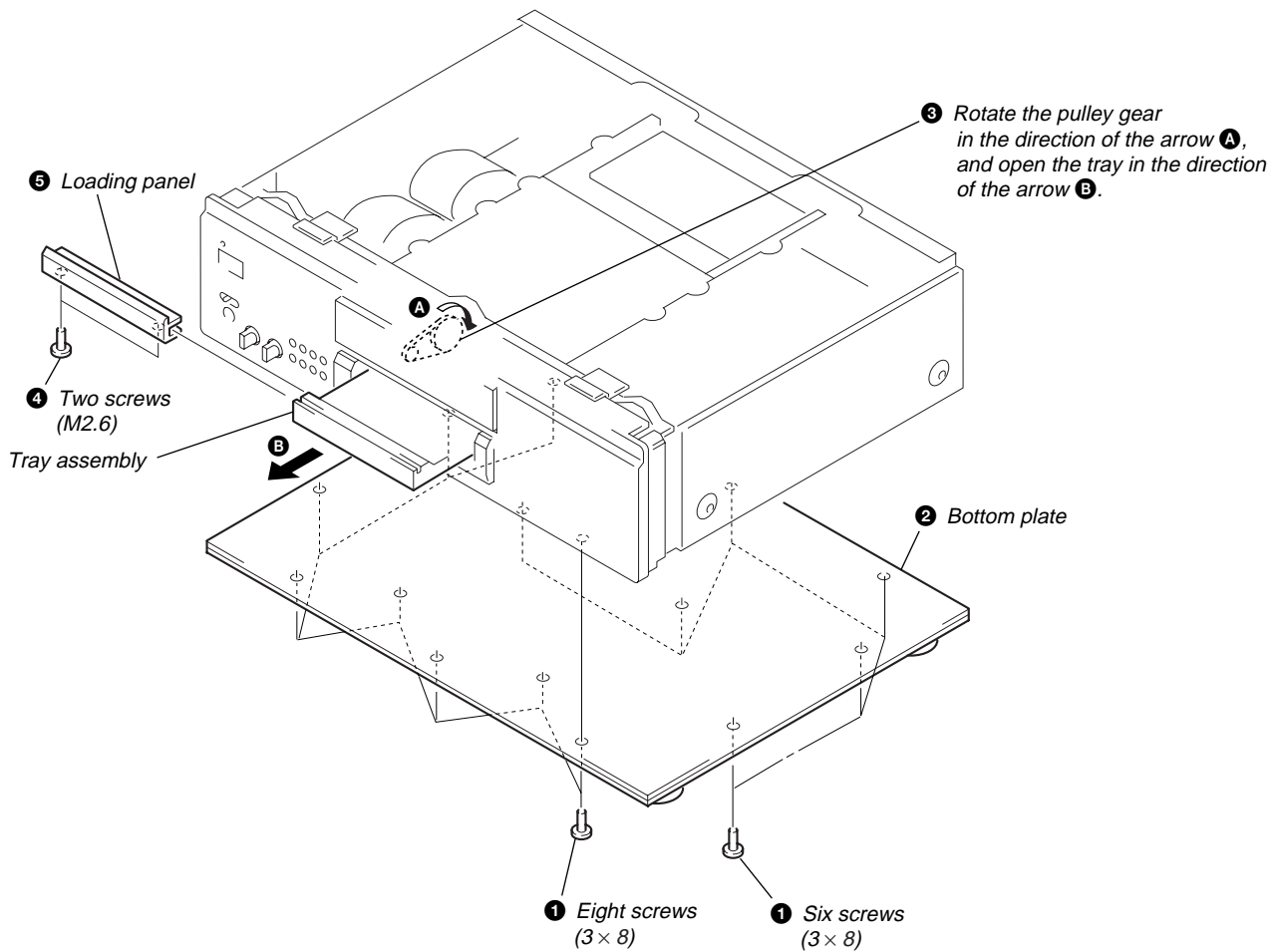

### 3-3. FRONT PANEL ASSEMBLY

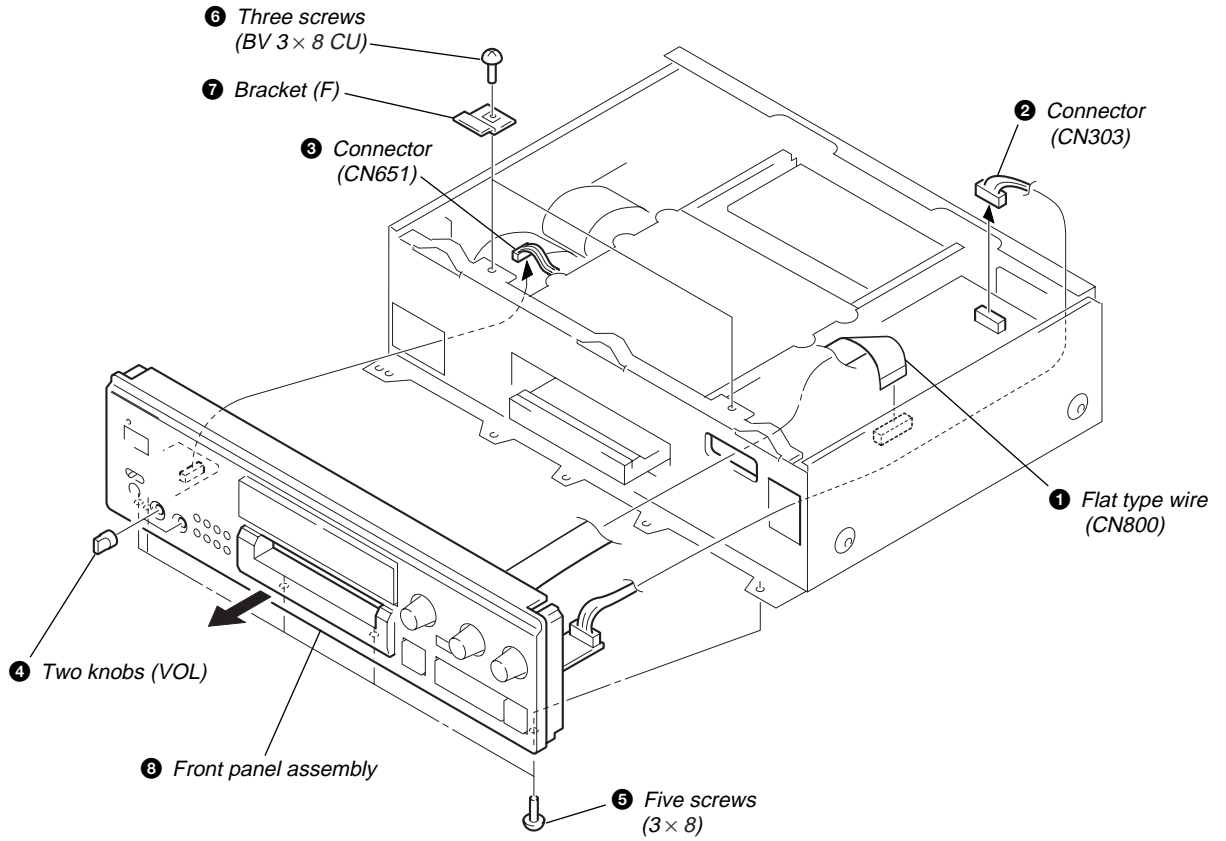

### 3-4. MD MECHANISM DECK

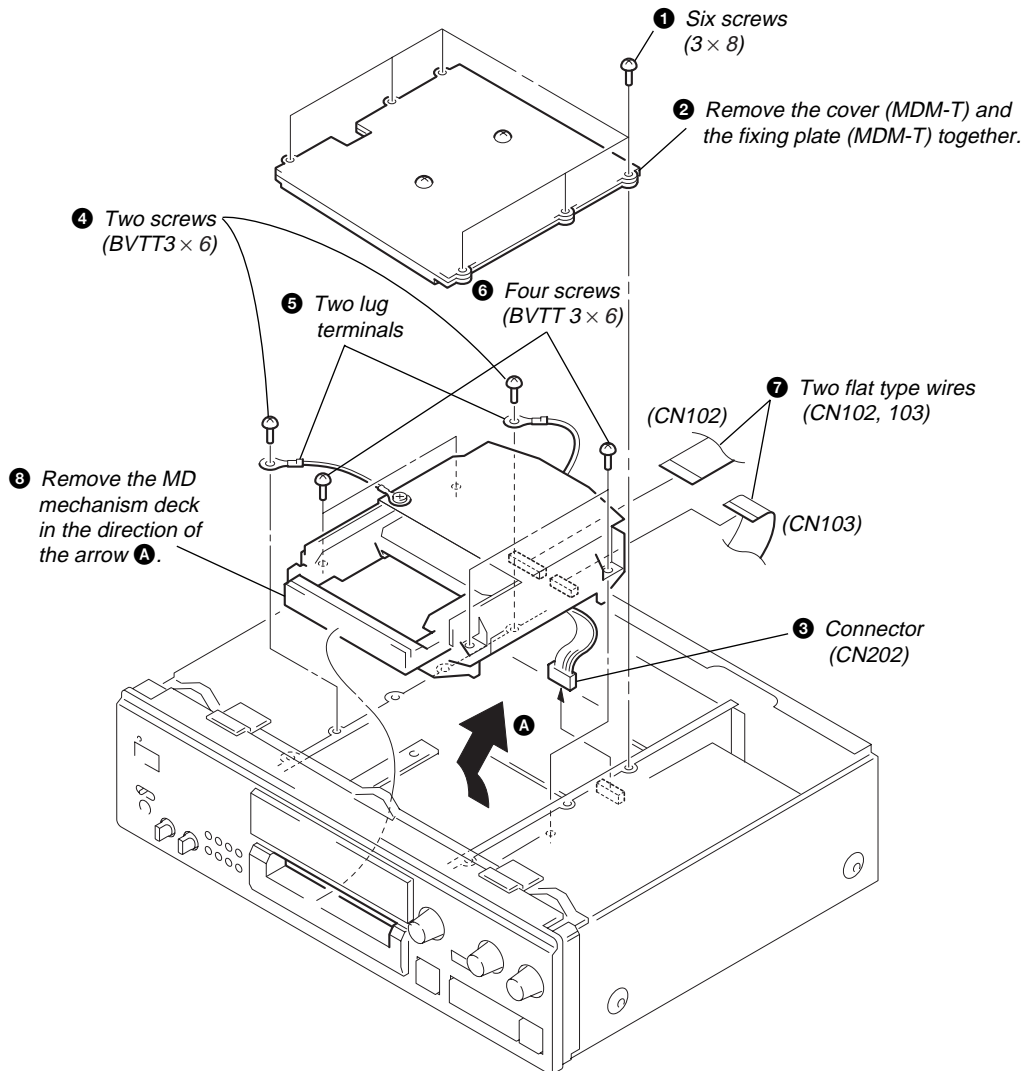

### 3-5. TRAY ASSEMBLY

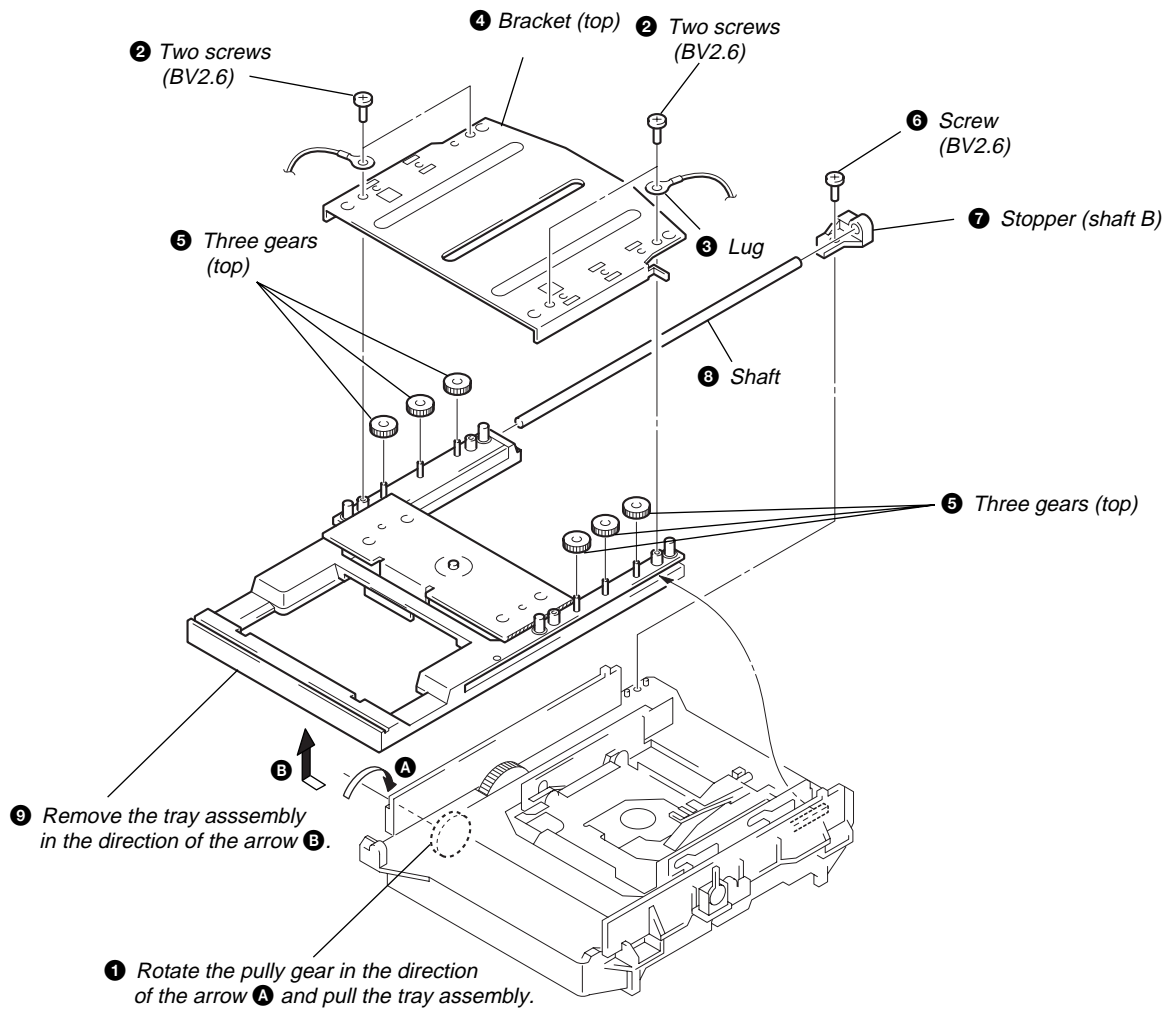

### NOTE FOR INSTALLATION

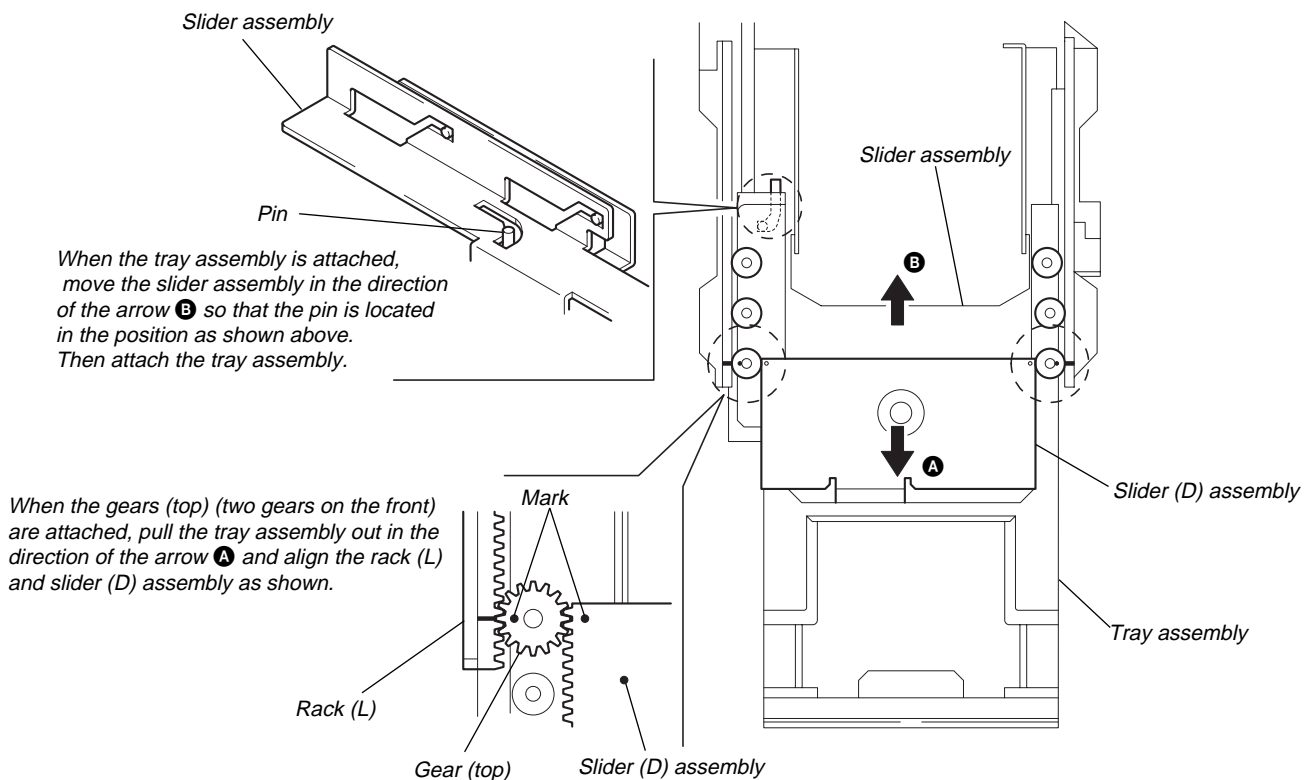



### 3-6. BU HOLDER ASSEMBLY

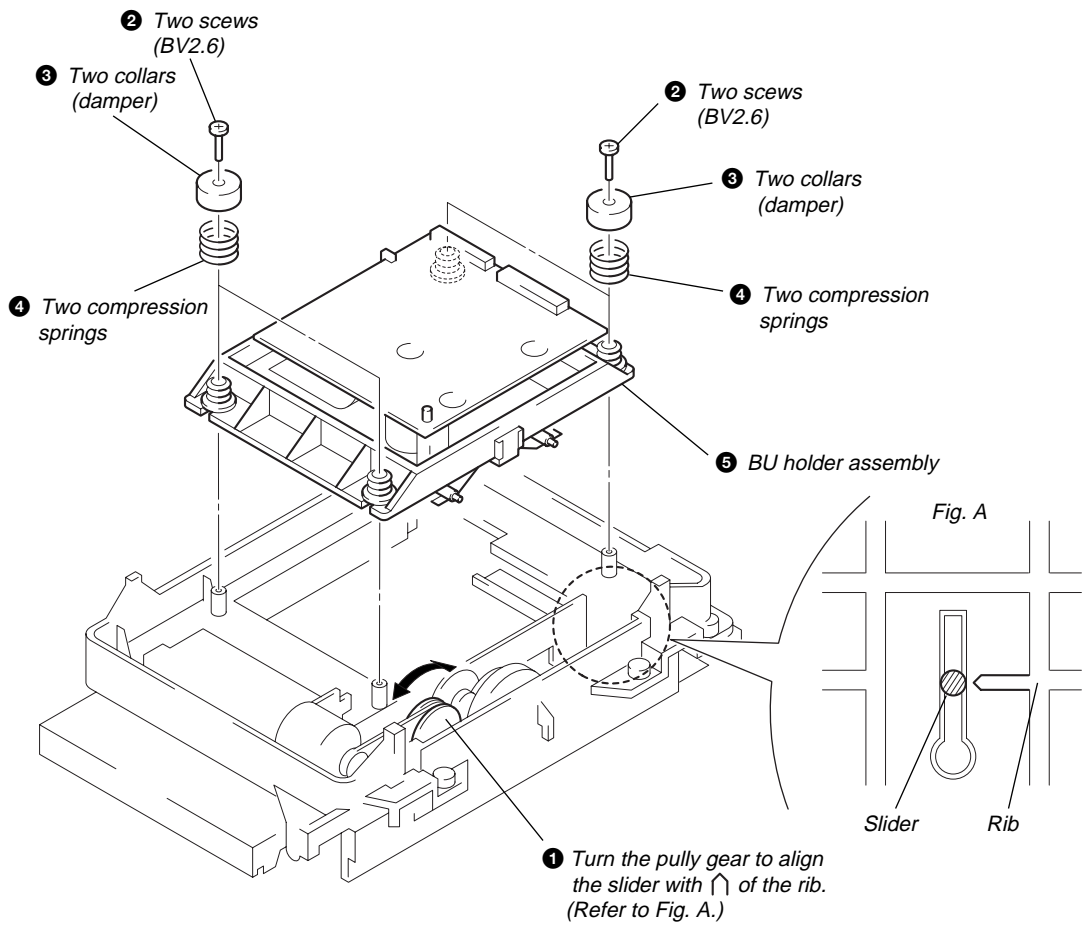

### 3-7. MOTOR (LOADING) ASSEMBLY (M10)

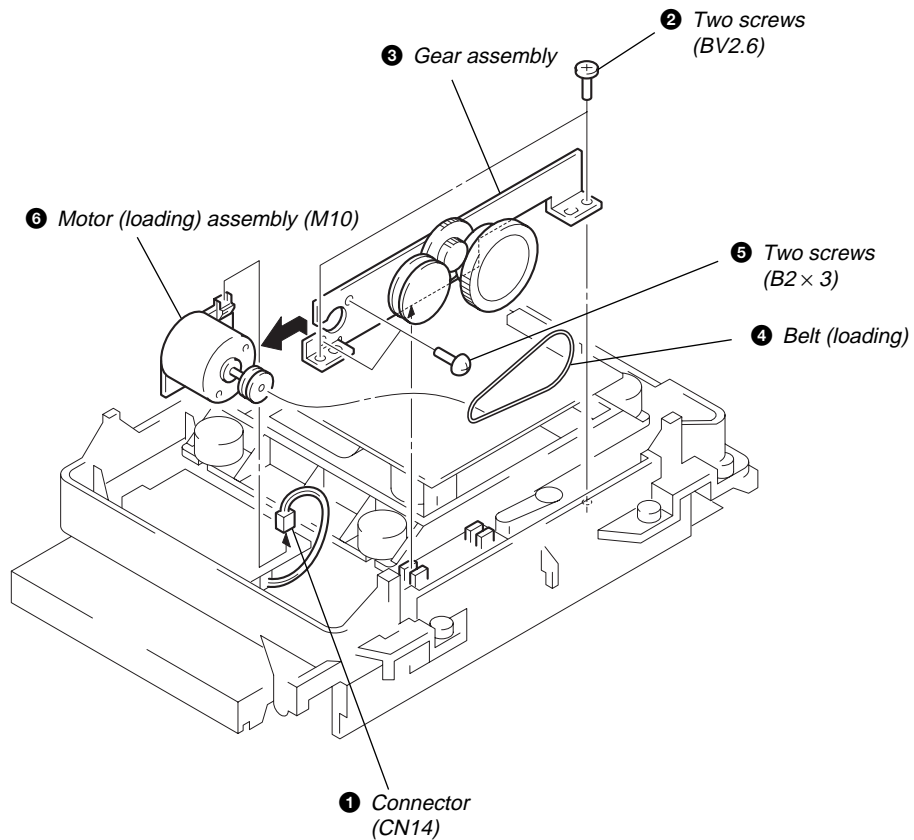

### 3-8. BASE UNIT (MBU-5C)

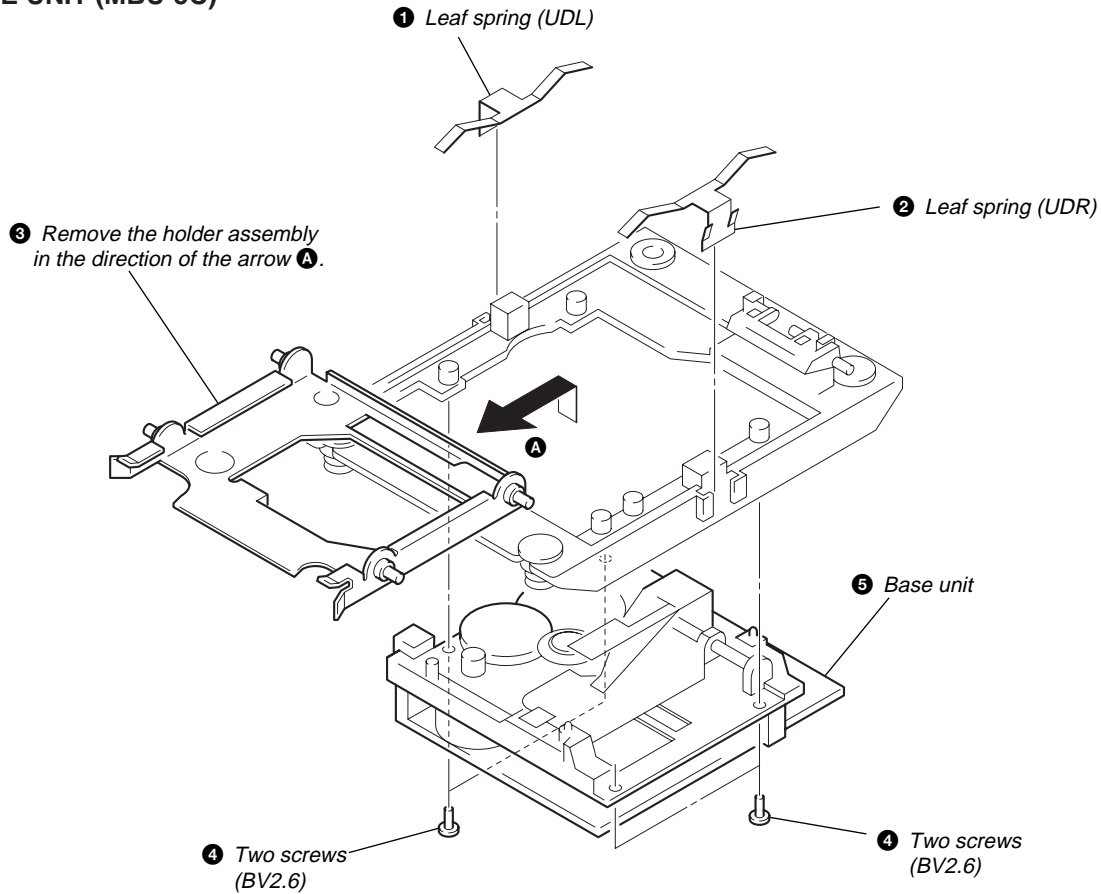

### 3-9. BD BOARD

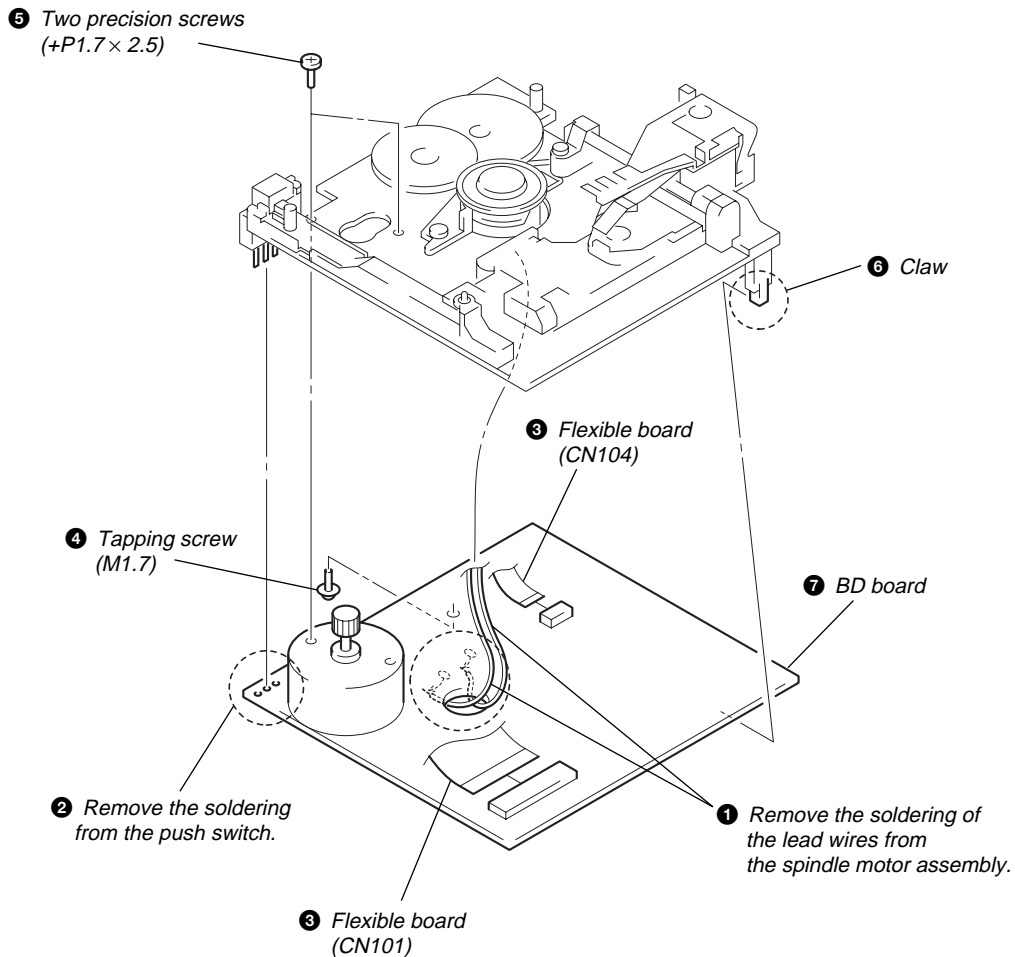

### 3-10. OVER LIGHT HEAD (HR901)

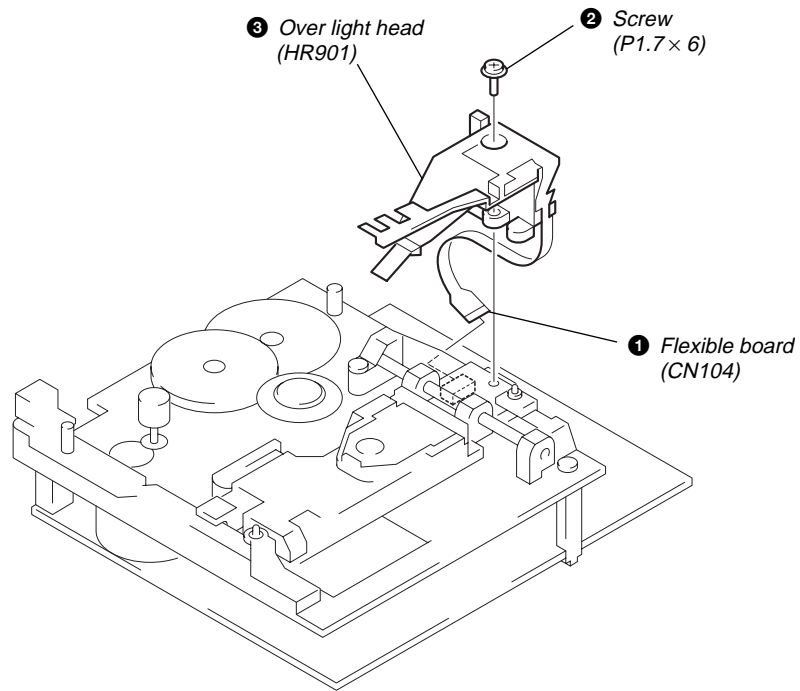

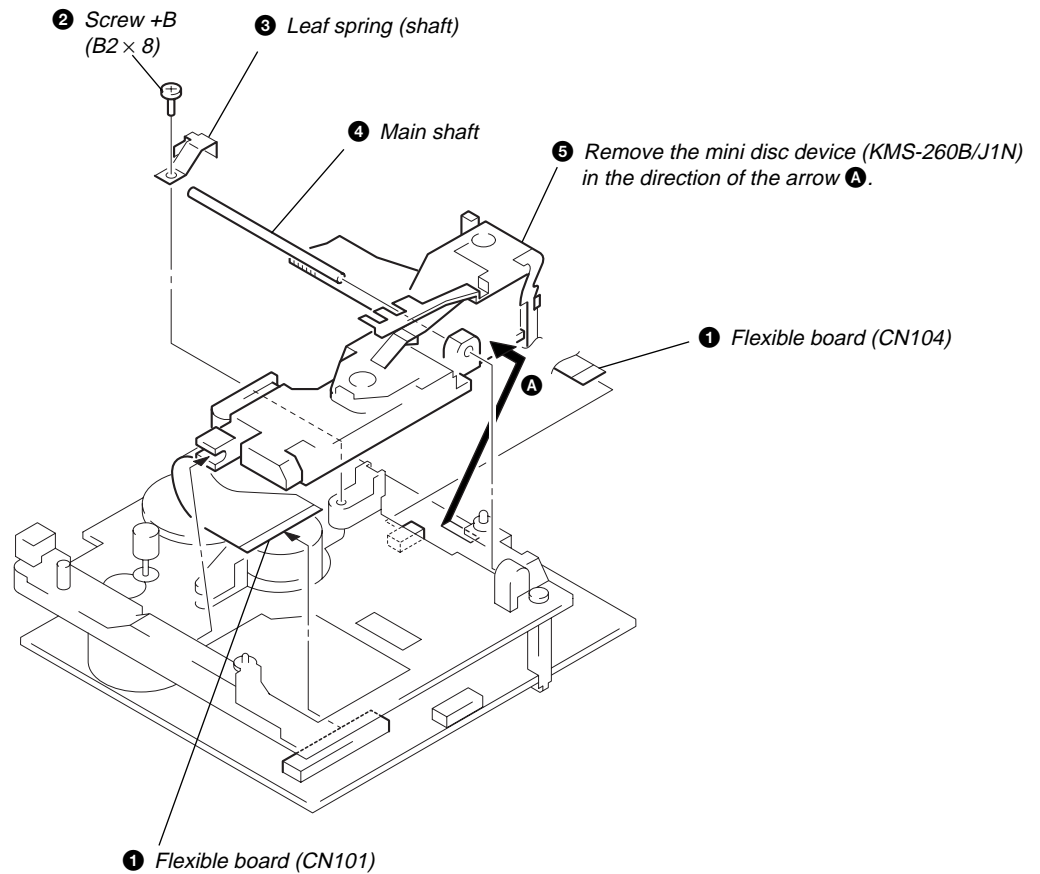

### 3-11. MINI DISC DEVICE (KMS-260B/J1N)



# SECTION 4 TEST MODE

## 4-1. Precaution on Using the Test Mode





- Be sure to insert and eject a disc after confirming that the disc in the MDS-JA555ES has come to complete stop because the loading related movements of the mechanism are performed without any relationship with the test mode.  
Disc does not stop rotating even through the  button is pressed while disc is rotating in the modes such as continuous playback and continuous recording. Therefore, the disc is ejected while it is rotating.  
Be sure to press the  button, then press the  button after a disc has completely stopped of its rotation.

### 4-1-1. Modes in Which Recording Laser Emits the Light and the Button Operations



- Continuous recording mode (CREC MODE)
- Laser power check mode (LDPWR CHECK)
- Laser power adjustment mode (LDPWR ADJUST)
- Traverse (MO) check (EF MO CHECK)
- Traverse (MO) check (EF MO ADJUST)
- When the  button is pressed

## 4-2. How to Enter the Test Mode

There are two methods to enter the test mode as follows.

Method 1: Connect the power plug to the outlet while pressing the  knob and  button at the same time, and remove the  knob and  button at the same time.

When the unit enters the test mode, “[Check]” appears. The four groups can be switched, .....↔ Check ↔Adjust ↔Service ↔Develop ↔....., by rotating the  knob.

Method 2: Connect the power plug to the outlet while pressing the  knob, and remove the  knob.



When the unit enters the test mode, “TEMP CHECK” appears. When the test mode is entered using this method, the contents of check group at method 1 can be performed.

## 4-3. Exiting the Test Mode

Press the  button. The display and LEDs of the pitch control and the filter are turned off. The MDS-JA555ES enters the standby status and exits the test mode.

## 4-4. Basic Operation of the Test Mode

All operations are performed using the  knob,  button, and  button. The functions of these button are as follows.

| Function  | Contents                                     |
|---|--|
|  knob   | Changes parameters and modes                 |
|  button | Proceeds onto the next step. Finalize input. |
|  button | Returns to previous step. Stops operations.  |

#### 4-5. Selecting the Test Mode

There are 31 types of the test mode. The group can be switched by rotating the  $\llcorner\llcorner\text{AMS}\ggg\ggg$  knob. Select the group to be used and press the  $\llcorner\llcorner\text{YES}\ggg\ggg$  button. After each group is entered, each mode can be switched by rotating the  $\llcorner\llcorner\text{AMS}\ggg\ggg$  knob.

For the selected contents, refer to the “Group” column in the list.

The group S can support all test modes for servicing. Be careful not to select other groups if not necessary.

| Display     | No. | Contents  | Mark    | Group (*) |
|-------------|-----|---|---------|-----------|
| TEMP CHECK  | C01 | Temperature compensation offset check                     |         | C S       |
| LDPWR CHECK | C02 | Laser power check   |         | C S       |
| EF MO CHECK | C03 | Traverse (MO) check                                       |         | C S       |
| EF CD CHECK | C04 | Traverse (CD) check                                       |         | C S       |
| FBIAS CHECK | C05 | Focus bias check  |         | C S       |
| ScurveCHECK | C06 | S curve check   | (×)     | C         |
| VERIFYMODE  | C07 | Non-volatile memory check                                 | (×)     | C         |
| DETRK CHECK | C08 | Detrack check   | (×)     | C         |
| TEMP ADJUS  | C09 | Temperature compensation offset adjustment                |         | A S       |
| LDPWR ADJUS | C10 | Laser power adjustment                                    |         | A S       |
| EF MO ADJUS | C11 | Traverse (MO) adjustment                                  |         | A S       |
| EF CD ADJUS | C12 | Traverse (CD) adjustment                                  |         | A S       |
| FBIAS ADJUS | C13 | Focus bias adjustment                                     |         | A S       |
| EEP MODE    | C14 | Non-volatile memory control                               | (×) (!) | D         |
| ERR DP MODE | C17 | Error history display, clear                              |         | S         |
| ADJ CLEAR   | C24 | Initialization of non-volatile memory of adjustment value |         | A S       |
| AG Set (MO) | C25 | Auto gain output level adjustment (MO)                    |         | A S       |
| AG Set (CD) | C26 | Auto gain output level adjustment (CD)                    |         | A S       |
| Iop Read    | C27 | IOP data display  |         | C S       |
| Iop Write   | C28 | IOP data writing  |         | A S       |
| JA555 @@@@  | C29 | Version display of microprocessor                         |         | C S       |
| CPLAY MODE  | C30 | Continuous playback mode                                  |         | C A S D   |
| CREC MODE   | C31 | Continuous recording mode                                 |         | C A S D   |

(\*) Group

C : Check A : Adjust

S : Service D : Develop

- For detailed description of each adjustment mode, refer to Section 5 “Electrical Adjustments”.  
For “ERR DP MODE” (C17), refer to the self-diagnosis function of page 2.
- If a different adjustment mode has been selected by mistake, press the  $\llcorner\llcorner\text{MENU/NO}\ggg\ggg$  button to exit from it.
- The items marked (×) in the mark are not used in servicing, therefore they are not detailed. If select these modes accidentally, press the  $\llcorner\llcorner\text{MENU/NO}\ggg\ggg$  button immediately to exit from it. If the items marked (!) are selected especially, the unit could be operated wrongly by rewriting the contents of non-volatile memory. Be careful of it.

#### 4-5-1. Operating the Continuous Playback Mode



##### 1. Entering the continuous playback mode

1) Load the disc into the unit. (recordable disc or disc for playback)

The disc is loaded by pushing the tray.

2) Rotate the  knob to display "CPLAY MODE" (C30).

3) Press the  button to change the display to "CPLAY MID".

4) When access completes, the display changes the display to "C =  AD = .

**Note** : The value of the "" displayed on the screen indicates error rate and "ADER".

##### 2. Changing the parts to be played back

1) Press the  button during continuous playback to change the display as shown and move the played back part.



2) When access completes, the display changes to "C =  AD = .

**Note** : The value of the "" displayed on the screen indicates error rate and "ADER".

##### 3. Ending the continuous playback mode

1) Press the  button to change the display to "CPLAY MODE".

2) Press the  button to eject the disc.

**Note1** : The playback start addresses for IN, MID, and OUT are as follows.

IN : 40h cluster

MID : 300h cluster

OUT : 700h cluster

**Note 2** : When the  button is pressed during the continuous playback in order to switch the tracking servo ON and OFF, the message "SERVO ON" appears without displaying "CPLAY MODE" when the  button is pressed to end the continuous playback mode.

Also when the servo is turned off, the servo is turned on automatically, the message "SERVO ON" appears and then the mode ends afterward.

To change the display "SERVO ON" to the normal "mode" display, press the  button.

#### 4-5-2. Operating the Continuous Recording Mode (Use this mode for self record/playback check only)

1. Entering the continuous recording mode
  - 1) Load the recordable disc to the unit.  
The disc is loaded by pushing the tray.
  - 2) Rotate the [◀◀AMS▶▶] knob to display "CREC MODE" (C31).
  - 3) Press the [YES] button to change the display to "CREC MID".
  - 4) When access completes, the display changes the display to "CREC(□□□□)" and [REC] illuminates.

**Note** : The value of the "□□" displayed on the screen indicates the address of the recorded position.
2. Changing the parts to be recorded
  - 1) Press the [YES] button during continuous playback to change the display as shown and move the played back part. [REC] disappears during moving.



- 2) When access completes, the display changes to "CREC(□□□□)" and [REC] disappears.
- Note** : The value of the "□□" displayed on the screen indicates the address of the recorded position.

3. Ending the continuous recording mode
  - 1) Press the [MENU/NO] button. The display changes to "CREC MODE" and [REC] disappears.
  - 2) To eject the disc, press the [EJECT] button.

**Note 1:** The playback start addresses for IN, MID, and OUT are as follows.

  - N : 40h cluster
  - MID : 300h cluster
  - OUT : 700h cluster

**Note 2:** The [MENU/NO] button can be used to stop recording anytime.

**Note 3:** Do not perform continuous recording for long periods of time above 5 minutes.

**Note 4:** During continuous recording, be careful not to apply vibration.

#### 4-5-3. No-Volatile Memory Mode (EEP MODE)

This mode reads and writes the contents of the non-volatile memory. It is not used in servicing. If selecting this mode accidentally, press the [MENU/NO] button immediately to exit it.

#### 4-6. Functions of Other Buttons

| Function name | Main contents  |
|---------------|--|
| ▶             | Sets continuous playback when pressed in the STOP state. When pressed during continuous playback, the tracking servo turns ON/OFF. *Note |
| ■             | Stops continuous playback and continuous recording   |
| ▶▶            | The sled moves to the outer circumference only when this is pressed  |
| ◀◀            | The sled moves to the inner circumstance only when this is pressed   |
| SCROLL        | Switches between the pit and groove modes when pressed   |
| PLAY MODE     | Switches the spindle servo mode (CLV S ↔ CLV A)  |
| DISPLAY/CHAR  | Switches the display when pressed  |
| ≡/OPEN/CLOSE  | Removes the disc   |
| REPEAT        | Exits test mode  |

**Note** : If the continuous playback mode ends with the tracking servo OFF, the tracking servo is automatically turned on. When the message "SERVO ON" appears at the end, press the [■] button to returns to the normal "mode" display.

## 4-7. Test Mode Displays

Each time the **DISPLAY/CHAR** button is pressed, the display changes in the following order.

### 1. MODE display

Displays “TEMP CHECK”, “CPLAY MODE”, etc.

### 2. Error rate display

Error rates are displayed as follows.

C = [ ][ ][ ][ ] AD = [ ][ ]

C = Indicates CI error

AD = Indicates ADER

### 3. Address display

Addresses are displayed as follows.

(MO: recordable disc, CD: disc for playback only)

Every pressing of the **SCROLL** button toggles between the groove display and the pit display

h = [ ][ ][ ][ ] s = [ ][ ][ ][ ] (MO pit and CD)

h = [ ][ ][ ][ ] a = [ ][ ][ ][ ] (MO groove)

h = : Indicates header address

s = : Indicates SUBQ address

a = : Indicates ADIP address

**Note:** The display “-” appears when the servo is not locked.

### 4. Auto gain display (not used in servicing)

The auto gain display is shown as follows.

AG=[ ][ ]/[ ][ ][ ] [ ][ ]

### 5. Detrack check display (not used in servicing)

The detrack check display is shown as follows.

ADR=[ ][ ][ ][ ][ ][ ][ ]

### 6. IVR display (not used in servicing)

The IVR display is shown as follows.

[ ][ ][ ] [ ][ ][ ] [ ][ ][ ]

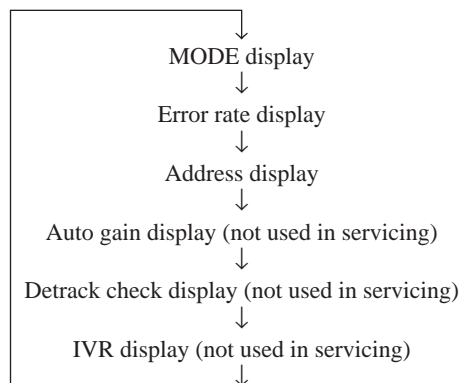

## Meaning of Other Displays

| Display  | Contents                             |                            |
|----------|--------------------------------------|----------------------------|
|          | MODE display                         | Off                        |
| ▷        | During continuous playback (CLV: ON) | STOP (CLV:OFF)             |
|          | Tracking servo OFF                   | Tracking servo ON          |
| REC      | Recording mode OFF                   | Recording mode OFF         |
| -SYNC    | CLV low speed mode                   | CLV normal mode            |
| A. SPACE | ABCD adjustment completed            |                            |
| OVER     | Tracking offset cancel ON            | Tracking offset cancel OFF |
| B        | Tracking auto gain OK                |                            |
| A-       | Focus auto gain OK                   |                            |
| TRACK    | Pit                                  | Groove                     |
| DISC     | High reflection                      | Low reflection             |
| SLEEP    | CLV-S                                | CLV-A                      |
| CLOCK    | CLV LOCK                             | CLV UNLOCK                 |



# SECTION 5 ELECTRICAL ADJUSTMENTS

## 5-1. On Part Replacement and Adjustment

- Perform the checks and adjustments of the MDM and MBU blocks following the procedure below .  
The procedure is changed depending on the replaced part.

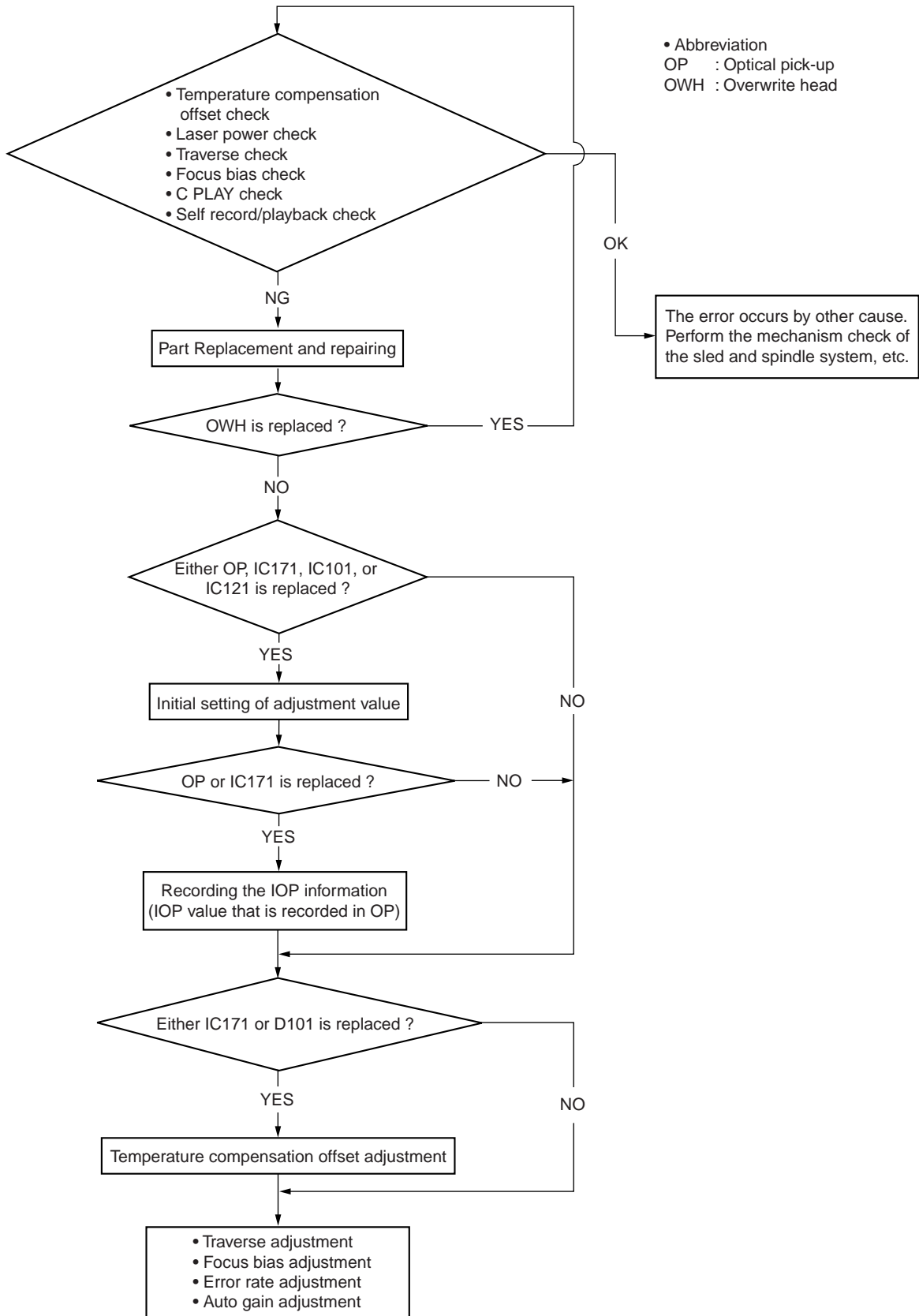

## 5-2. Precautions for Checking Laser Diode Emission

To check the emission of the laser diode during adjustments, never view directly from the top as this may lose your eye-sight.

## 5-3. Precautions for Use of Optical Pick-up (KMS-260B)

As the laser diode in the optical pick-up is easily damaged by static electricity, solder the laser tap on the flexible board of the optical pick-up when using it.

Before disconnecting the connector, disorder the laser tap. Be careful not to remove the solder before connecting the connector. Also take adequate measures to prevent damage by static electricity. Handle the flexible board with care as it breaks easily.

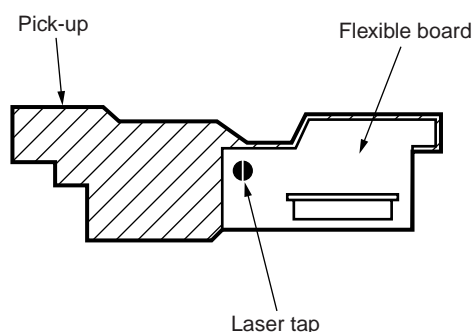

Optical pick-up flexible board

## 5-4. Precautions for Adjustments

1) When replacing the following parts, perform the adjustments and checks with !! in the order shown in the following table.

|   | Optical pick-up | BD board |      |              |       |
|---|-----------------|----------|------|--------------|-------|
|   |                 | IC171    | D101 | IC101, IC121 | IC192 |
| 1. Initial setting of adjustment value                              | ○               | ○        | ×    | ○            | ×     |
| 2. Recording IOP information (the value that is written in pick-up) | ○               | ○        | ×    | ×            | ×     |
| 3. Temperature compensation offset adjustment                       | ×               | ○        | ○    | ×            | ×     |
| 4. Laser power adjustment   | ○               | ○        | ×    | ○            | ○     |
| 5. Traverse adjustment  | ○               | ○        | ×    | ○            | ×     |
| 6. Focus bias adjustment  | ○               | ○        | ×    | ○            | ×     |
| 7. Error rate adjustment  | ○               | ○        | ×    | ○            | ×     |
| 8. Auto gain output level adjustment                                | ○               | ○        | ×    | ○            | ×     |

- 2) Set the test mode when performing the adjustments. After completing the adjustments, exit the test mode. Perform the adjustments and checks in "Group S" of the test mode.
- 3) Perform the necessary adjustments only in the order given.
- 4) Use the following tools and measuring devices.
  - Check disc (MD) TDYS-1 (Parts No.: 4-963-646-01)
  - Test disc (MDW-74/AU-1) (Parts No.: 8-892-341-41)
  - Laser power meter LPM-8001 (Parts No.: J-2501-046-A)
 Or
  - MD laser power meter 8010S (Parts No.: J-2501-145-A) (Note)
  - Oscilloscope (Measure after perform the CAL of the probe.)
  - Digital voltmeter
  - Thermometer
  - Tool for checking waveform of BD board (Parts No.: J-2501-149-A)
- 5) When observing several signals on the oscilloscope, etc., make sure that VC and ground do not connect inside the oscilloscope. (VC and ground will become short-circuited.)
- 6) When checking the waveform, the check can be performed without soldering by using the tool for checking waveform of BD board. (Refer to the Service note (page 6).)
- 7) Use the tool disc that is free from finger print and dust as they can affect result of adjustment.

### Note: Laser power meter

When the laser power check and adjustment of the electrical adjustment are performed, using the new MD laser power meter 8010S (J-2501-145-A) instead of the former laser power meter is recommended.

The procedure of installing the laser meter sensor to the objective lens of pickup is greatly simplified.

## 5-5. Creating Continuous Recorded Disc

- This disc is used in focus bias adjustment and error rate check. The following describes how to create a continuous recording disc.

- Load a disc (blank disc) commercially available. the disc is loaded by pushing the tray.
- Rotate the **[◀◀AMS▶▶]** knob and display “CREC MODE” (C31).
- Press the **[YES]** button to display “CMEC MID”. “CREC (0300)” is displayed for a moment and recording starts.
- Complete recording within 5 minutes.
- Press the **[MENU/NO]** button to stop recording.
- Press the **[EJECT]** button to eject the disc.

The above has been how to create a continuous recording data for the focus bias adjustment and error rate check.

### Note:

- Be careful not to apply vibration during continuous recording.

## 5-6. Check before Repairing

This check aims at locating the approximate position of cause of trouble before starting to replace parts using specifications.

For detailed information, refer to [Checks before Part Replacement and Adjustment] of Service note (page 9).

### 5-6-1. Temperature Compensation Offset Check

Before adjustment, set the internal temperature and the ambient temperature are between 22 and 28 °C.

Checking procedure:

- Rotate the **[◀◀AMS▶▶]** knob to display “TEMP CHECK” (C01).
- Press the **[YES]** button.
- It is OK when “T=@@(#) [OK]” appears. It is NG when “T=@@(#) [NG]” appears. (@@ is the current value. ## is the value that is written in the non-volatile memory.)

### 5-6-2. Laser Power Check

Before check:

- Refer to Section 1 “Service note” How to open the disc tray when power switch is turned off, and laser power check.
- Check the IOP value of optical pick-up. (Refer to Section 5-8 “Recording and displaying IOP information”.)

Connection:

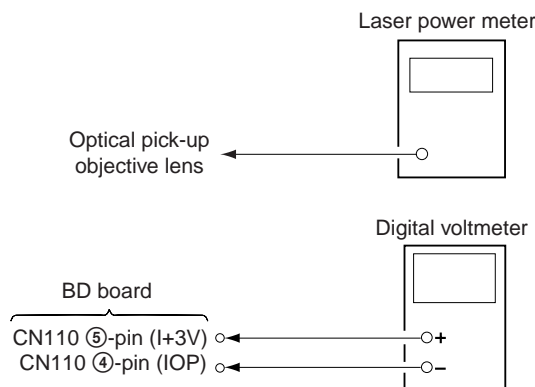

Checking procedure:

- Insert the laser power meter from the disc inlet and set it on the objective lens of the optical pick-up. (When it cannot be set properly, press the **[◀◀]** button and **[▶▶]** button to move the optical pick-up.)  
Connect the digital voltmeter to CN110 ⑤-pin (I+3V) and the CN110 ④-pin (IOP).
- Rotate the **[◀◀AMS▶▶]** knob to display “LDPWR CHECK” (C02).
- Press the **[YES]** button once to display “LD 0.9mW \$□□□”.  
Confirm that the reading of the laser power meter is 0.84 to 0.92 mW.
- Press the **[YES]** button once again to display “LD 7.0mW \$□□□”.  
Confirm that the readings of the laser power meter and digital bolt meter satisfy the specified value.

Specification:

Laser power meter reading: 7.0 +/- 0.2 mW

Digital bolt meter reading: Optical pick-up displayed value +/- 10 %

(Optical pick-up label)

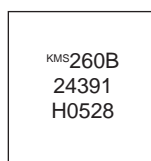

(For the checking procedure of this value, refer to Section 5-8 “Recording and displaying IOP information”.)

IOP = 52.8 mA in this case

$IOP (mA) = \text{digital bolt meter reading (mV)} / 1 (W)$

- Press the **[MENU/NO]** button to display “LDPWR CHECK” and stop laser emission.  
(The **[MENU/NO]** button is effective at all times to stop the laser emission.)

**Note 1** : After step 4, the display of “LD 0.7mW\$□□□” “LD 6.2mW\$□□□”, “LD WPcorrection \$□□□” is switched every time when pressing the **[YES]** button. Operation is not necessary for these displays.

### 5-6-3. Traverse Check

**Note 1** : If the recorded disc is used for this adjustment, the data is deleted.

**Note 2** : If the traverse waveform is not clear, connect the oscilloscope as shown below so that it can be seen more clearly.

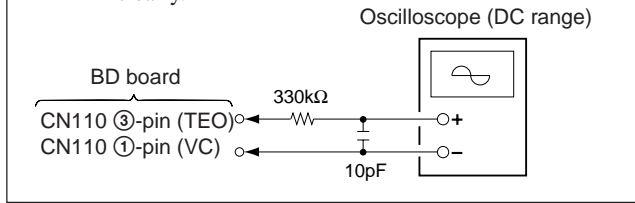

Connection:

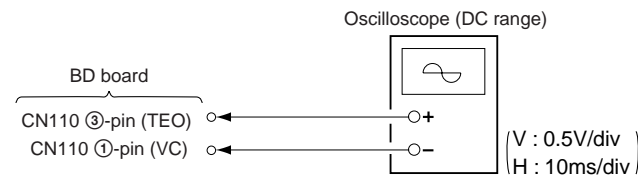

Checking procedure:

1. Connect the oscilloscope to the CN110 ③-pin (TEO) and the CN110 ①-pin (VC) of the BD board.
2. Load a recordable disc (any available on the market). (Refer to Note 1.)  
The disc is loaded by pushing the tray.
3. Press the button to move the optical pick-up outside the pit.
4. Rotate the knob to display “EF MO CHECK” (C03).
5. Press the button to display “EFB = MO-R”. (Laser power READ power, focus servo ON, tracking servo OFF, and spindle (S) servo ON are set)
6. Observe the waveform of the oscilloscope and confirm it is within the specified value. Do not rotate the knob at that time.  
(Read power traverse check)

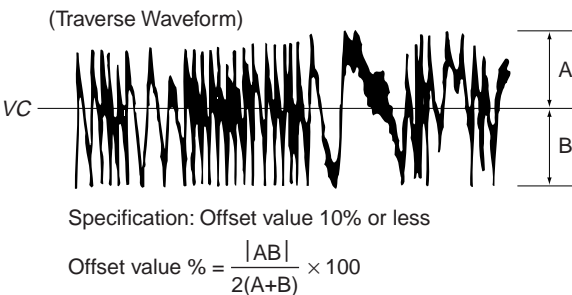

7. Press the button to display “EFB = MO-W”.

8. Observe the waveform of the oscilloscope and confirm it that is within the specified value. Do not rotate the knob at this time.  
(Write power traverse check)

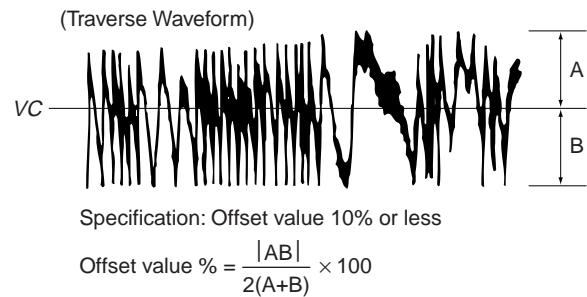

9. Press the button to display “EFB = MO-P”. The optical pick-up moves to the internal circumference of the pit area automatically and servo is imposed.
10. Observe the waveform of the oscilloscope and confirm that it is within the specified value. Do not rotate the knob at this time.

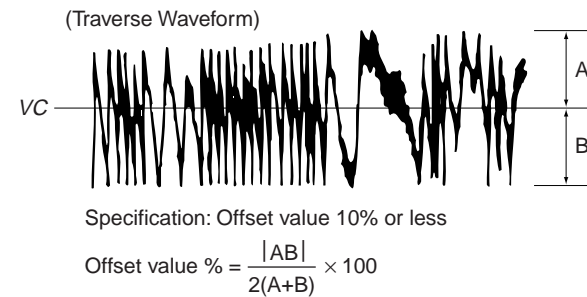

11. Press the button to display “EF MO CHECK”. The disc stops rotating automatically.
12. Press the button to eject the disc.
13. Load the check disc (MD) TDYS-1.
14. Rotate the knob to display “EF CD CHECK” (04).
15. Press the button to display “EFB = CD”. The servo is imposed automatically.
16. Observe the waveform of the oscilloscope and confirm that it is within the specified value. Do not rotate the knob at this time.

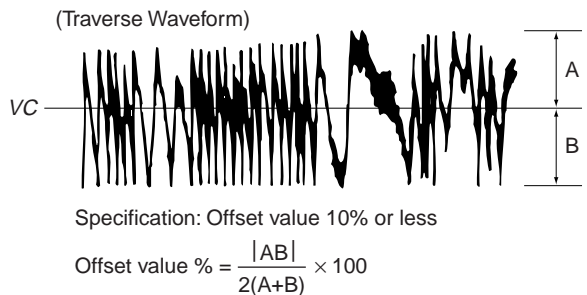

17. Press the button to display “EF CD CHECK”.
18. Press the button to eject the check disc (MD) TDYS-1.

#### 5-6-4. Focus Bias Check

Change the focus bias to check the focus tolerance amount.

Checking procedure:

1. Load the test disc (MDW-74/AU-1).  
The disc is loaded by pushing the tray.
2. Rotate the  knob to display "CPLAY MODE" (C30).
3. Press the  button to display "CPLAY MID".
4. After "C =  AD =  appears, press the  button.
5. Rotate the  knob to display "FBIAS CHECK" (C05).
6. Press the  button to display "/ c = ".  
The first four digits indicate the C1 error rate, the two digits after "/" indicate ADER, and the two digits after "c = " indicate the focus bias amount.  
Confirm that the C1 error is below 220 and the ADER is below 2.
7. Press the  button to change the display to "/ b = ".  
Confirm that the C1 error is below 220 and the ADER is below 2.
8. Press the  button to change the display to "/ a = ".  
Confirm that the C1 error is below 220 and the ADER is below 2.
9. Press the  button and press the  button to eject the test disc.

#### 5-6-5. C PLAY Check

MO rate check

Checking procedure:

1. Load a test disc (MDW-74/AU-1).  
The disc is loaded by pushing the tray.
2. Rotate the  knob to display "CPLAY MODE" (C30).
3. Press the  button to display "CPLAY MID".
4. The display is changed to "C =  AD = ".
5. Confirm that the C1 error rate is below 80 and the ADER is below 2.
6. Press the  button to stop playing back. Press the  button to eject the test disc.

MO rate check

Checking procedure:

1. Load a check disc (TDYS-1).  
The disc is loaded by pushing the tray.
2. Rotate the  knob to display "CPLAY MODE" (C30).
3. Press the  button to display "CPLAY MID".
4. The display is changed to "C =  AD = ".
5. Confirm that the C1 error rate is below 50.
6. Press the  button to stop playing back. Press the  button to eject the check disc.

#### 5-6-6. Self Record/Playback Check

- The error rate is checked using the self record/playback disc. Manufacture the self record/playback disc by user locally using the MDS-JA555ES that is going to be measured of its error rate by means of continuous recording.

Checking procedure:

1. Load a recordable disc (blank disc) into the unit.  
The disc is loaded by pushing the tray.
2. Rotate the  knob to display "CREC MODE" (C31).
3. Press the YES button to display "CPLAY MID".
4. When recording starts, the message  appears and the message changed to "CREC (@@@@)" (@@@@ is an address) and recording starts.
5. After one minute, press the  button to stop continuous recording.
6. Rotate the  knob to display "CREC MODE" (C30).
7. Press the YES button to display "CPLAY MID".
8. Display "C =  AD = ".
9. Confirm that the C1 error rate is below 80 and the AD error rate is below 2.
10. Press the  button to stop playing back. Press the  button to eject the check disc.

#### 5-7. Returning to Initial Setup of Adjustment Value

Note:

The adjustment result that is stored in the non-volatile memory is all cleared and returned to the initial setup value when procedure is performed. However, the adjustment result of the temperature compensation offset adjustment remains unchanged. When this procedure is performed, be sure to perform all adjustments from very beginning to the end again except the temperature compensation offset adjustment. Perform this procedure as necessary before starting adjustment referring to section "5-4. Precautions for Adjustments".

Setting procedure:

1. Rotate the  knob to display "ADJ CLEAR" (C24).
2. After pressing the YES button, "Complete!" appears for a moment and the initial setting is started. Then, "ADJ CLEAR" appears.

## 5-8. Recording and Displaying the IOP Information

The IOP data that is indicated on the pickup, can be saved in the non-volatile memory of the MDS-JA555ES. The IOP data that is printed on the optical pickup and the IOP data after adjustment is completed can be saved in the memory. Saving the IOP data in the memory eliminates the needs to look at the printed value on the label that is attached on the surface of optical pick, and enables to view the IOP data on display.

### Recording procedure:

1. Rotate the **[◀◀AMS▶▶]** knob to display “Iop Write” (C28). Press the **[YES]** button.
2. “Ref=@@.@” (@ is arbitrary number.) appears and the values that can be changed flash.
5. Input the value of IOP that is written in the optical pick-up.  
Selecting figure: Rotate the **[◀◀AMS▶▶]** knob.  
Selecting digit : Press the **[◀◀AMS▶▶]** knob.
6. Press the **[YES]** button and “Measu=@@.@” (@ is arbitrary number.) appears.
7. The value of step 4 is used to record the adjustment result, so press the **[YES]** button.
8. “Complete!” appears for a moment, and the value is recorded in the non-volatile memory. Then, “Iop Write” appears.

### Displaying procedure:

1. Rotate the **[◀◀AMS▶▶]** knob to display “Iop Write” (C27) and press the **[YES]** button.
4. “@@.@/##.#” appears and the contents that is recorded are displayed.  
@@.@: The value of IOP that is described in pick-up  
##.#: The value of IOP after adjustment
5. When the display is completed, press the **[◀◀AMS▶▶]** knob or **[MENU/NO]** button to display “Iop Read”.

## 5-9. Temperature Compensation Offset Adjustment

The temperature data at 25°C is used as the reference data and is saved in the non-volatile memory for offset adjustment.

### Note.

1. Do not perform this adjustment normally.
2. Perform this adjustment under the ambient temperature in the range of 22 to 28 °C. Perform this adjustment immediately after the main power is turned on in which the internal temperature of MDS-JA555ES is still the same as the ambient temperature.
3. After replacing the D101, wait the until the temperature of the parts become the same as the ambient temperature and perform this adjustment.

### Checking procedure:

1. Rotate the **[◀◀AMS▶▶]** knob to display “TEMP CHECK” (C09).
2. Press the **[YES]** button and select the “TEMP ADJUS” mode.
3. “TEMP=□□[OK]” and the current temperature data appear.
4. When the data is saved: Press the **[YES]** button  
When the data is not saved: Press the **[MENU/NO]** button
5. When the **[YES]** button is pressed, “TEMP = □□ SAVE” and “TEMP ADJUST” appear.  
When the **[MENU/NO]** button is pressed, the display is changed to “TEMP ADJUD” immediately.

### Specified value:

The value of TEMP = □□ is within E0 to EF, F0 to FF, 00 to 0F, 10 to 1F, and 20 to 2F.

## 5-10. Laser Power Adjustment

### Before adjustment:

Confirm the IOP value of optical pick-up. (Refer to Section 5-8 “Recording and displaying the IOP information”).

### Connection:

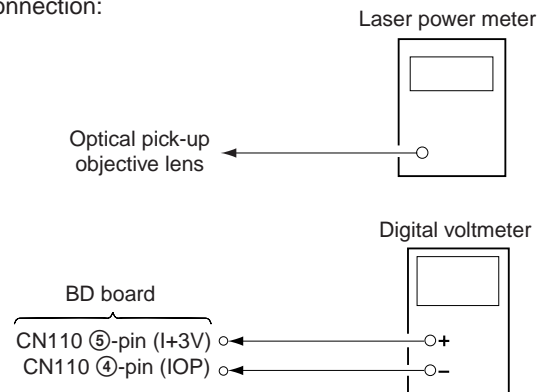

### Adjustment procedure:

1. Insert the laser power meter from the disc inlet and set it on the objective lens of the optical pick-up. (When it cannot be set properly, press the **[◀◀]** button and **[▶▶]** button to move the optical pick-up.)  
Connect the digital voltmeter to CN110 ⑤-pin (I+3V) and the CN110 ④-pin (IOP).

2. Rotate the  $\llbracket \llcorner \llcorner \text{AMS} \gg \gg \rrbracket$  knob to display "LDPWR CHECK" (C10).  
(laser power: for adjustment)
3. Press the  $\llbracket \text{YES} \rrbracket$  button once to display "LD 0.9mW \$  $\square\square\square$ ".
4. Set the lens knob of the laser power meter to 10 mW, press the YES button, and save the adjustment results in the non-volatile memory. ("LD SAVE \$  $\square\square$ " appears for a moment at this time.)
5. "LD 7.0mW \$  $\square\square\square$ " is displayed.
6. Rotate the  $\llbracket \llcorner \llcorner \text{AMS} \gg \gg \rrbracket$  knob so that the reading of the laser power meter is 6.9 to 7.1 mW. Press the  $\llbracket \text{YES} \rrbracket$  button and save it. ("LD SAVE \$  $\square\square$ " appears for a moment at this time.)  
**Note:** Do not perform the emission of 7.0 mW continuously for 15 seconds and more.
7. Rotate the  $\llbracket \llcorner \llcorner \text{AMS} \gg \gg \rrbracket$  knob to display "LDPWR CHECK" (C02).
8. Press the  $\llbracket \text{YES} \rrbracket$  button once to display "LD 0.9mW \$  $\square\square\square$ ".  
The reading of laser power meter is 0.85 to 0.91 mW.
9. Press the  $\llbracket \text{YES} \rrbracket$  button once to display "LD 7.0mW \$  $\square\square\square$ ".  
The reading of laser power meter is within the specified value.  
Take note of the digital bolt meter reading.

(Optical pick-up label)

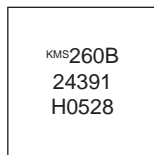

(For the checking procedure of this value, refer to Section 5-8 "Recording and displaying IOP information".)

IOP = 52.8 mA in this case  
 $\text{IOP (mA)} = \text{digital bolt meter reading (mV)} / 1 \text{ (W)}$

10. Press the  $\llbracket \text{MENU/NO} \rrbracket$  button to display "LDPWR CHECK" and stop laser emission.  
(The  $\llbracket \text{MENU/NO} \rrbracket$  button is effective at all times to stop the laser emission.)
11. Rotate the  $\llbracket \llcorner \llcorner \text{AMS} \gg \gg \rrbracket$  knob to display "Iop Write" (C28).
12. Press the  $\llbracket \text{YES} \rrbracket$  button and after "Ref=@@.@." (@ is arbitrary number.) appears press the YES button to display "Measu=@@.@." (@ is arbitrary number.)
13. The changeable value flashes. Input the IOP value that is written at step 9.  
Selecting figure: Rotate the  $\llbracket \llcorner \llcorner \text{AMS} \gg \gg \rrbracket$  knob.  
Selecting digit : Press the  $\llbracket \llcorner \llcorner \text{AMS} \gg \gg \rrbracket$  knob.
14. After pressing the  $\llbracket \text{YES} \rrbracket$  button, "Complete!" appears for a moment, and the value is recorded in the non-volatile memory. Then, "Iop Write" appears.

**Note 1:** After step 9, the display of "LD 0.7mW\$  $\square\square$ " "LD 6.2mW\$  $\square\square$ ", "LC WPcorrection \$  $\square\square$ " is switched every time when pressing the YES button. Operation is not necessary for these displays.

## 5-11. Traverse Adjustment

**Note1:** If the recorded disc is used for this adjustment, the data is deleted.

**Note2:** If the traverse waveform is not clear, connect the oscilloscope as shown below so that it can be seen more clearly.

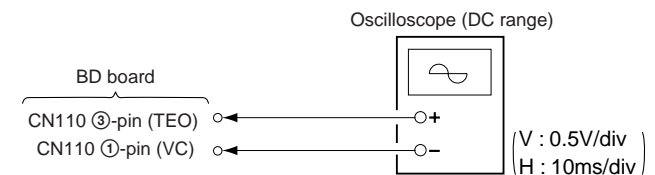
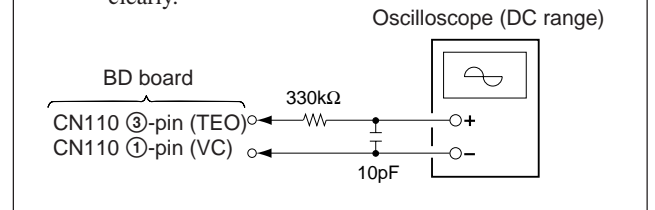

Adjustment procedure:

1. Connect the oscilloscope to the CN110 ③-pin (TEO) and the CN110 ①-pin (VC) of the BD board.
2. Load a recordable disc (any available on the market). (Refer to Note 1.)  
The disc is loaded by pushing the tray.
3. Press the  $\llbracket \blacktriangleright \rrbracket$  button to move the optical pick-up outside the pit.
4. Rotate the  $\llbracket \llcorner \llcorner \text{AMS} \gg \gg \rrbracket$  knob to display "EF MO ADJUS" (C11).
5. Press the YES button to display "EFB =  $\square\square$  MO-R".  
(Laser power READ power, focus servo ON, tracking servo OFF, and spindle (S) servo ON are set)
6. Rotate the  $\llbracket \llcorner \llcorner \text{AMS} \gg \gg \rrbracket$  knob so that the waveform of the oscilloscope is the specified value. (The figure  $\square\square$  of the "EFB =  $\square\square$ " and the waveform are changed by rotating the  $\llbracket \llcorner \llcorner \text{AMS} \gg \gg \rrbracket$  knob.) In this adjustment, the waveform varies at intervals of approx. 2%. Adjust the waveform so that the specified value is satisfied as much as possible.  
(Read power traverse adjustment)

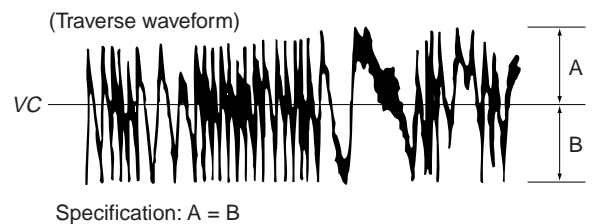

7. Press the  $\llbracket \text{YES} \rrbracket$  button to save the adjustment results in the non-volatile memory. (At this time "EFB =  $\square\square$  SAV" is displayed for a moment, and then "EFB =  $\square\square$  MO-W" is displayed.)

8. Rotate the  $\llbracket \llcorner \llcorner \text{AMS} \gg \gg \rrbracket$  knob so that the waveform of the oscilloscope is the specified value. (The figure  $\square \square$  of the “EFB =  $\square \square$ ” and the waveform are changed by rotating the  $\llbracket \llcorner \llcorner \text{AMS} \gg \gg \rrbracket$  knob.) In this adjustment, the waveform varies at intervals of approx. 2%. Adjust the waveform so that the specified value is satisfied as much as possible.  
(Write power traverse adjustment)

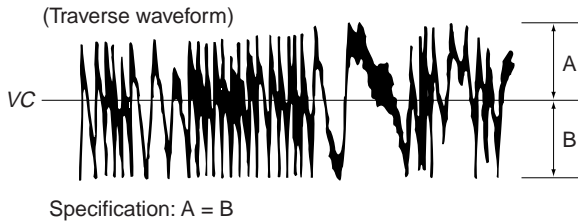

9. Press the  $\llbracket \text{YES} \rrbracket$  button to save the adjustment results in the non-volatile memory. (At this time “EFB =  $\square \square$  SAV” is displayed for a moment)  
 10. “EFB = MO-P” appears and the optical pick-up moves to the internal circumference of the pit area automatically and servo is imposed.  
 11. Rotate the  $\llbracket \llcorner \llcorner \text{AMS} \gg \gg \rrbracket$  knob so that the waveform of the oscilloscope moves closer to the specified value.  
 In this adjustment, the waveform varies at intervals of approx. 2%. Adjust the waveform so that the specified value is satisfied as much as possible.  
(Write power traverse adjustment)

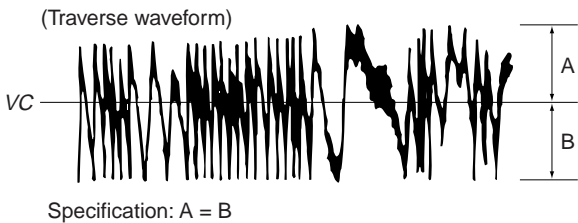

12. Press the  $\llbracket \text{YES} \rrbracket$  button to save the adjustment results in the non-volatile memory. (At this time “EFB =  $\square \square$  SAV” is displayed for a moment)  
 Then, “EF MO ADJUS” appears and the disc stops rotating automatically.  
 13. Press the  $\llbracket \text{EJECT} \rrbracket$  button to eject the disc.  
 14. Load a check disc (TDYS-1).  
 The disc is loaded by pushing the tray.  
 15. Rotate the  $\llbracket \llcorner \llcorner \text{AMS} \gg \gg \rrbracket$  knob to display “EF CD ADJUS” (C12).  
 16. Press the  $\llbracket \text{YES} \rrbracket$  button to display “EFB =  $\square \square$ CD”. The servo is imposed automatically.  
 17. Rotate the  $\llbracket \llcorner \llcorner \text{AMS} \gg \gg \rrbracket$  knob so that the waveform of the oscilloscope makes closer to the specified value.  
 In this adjustment, the waveform varies at intervals of approx. 2%. Adjust the waveform so that the specified value is satisfied as much as possible.

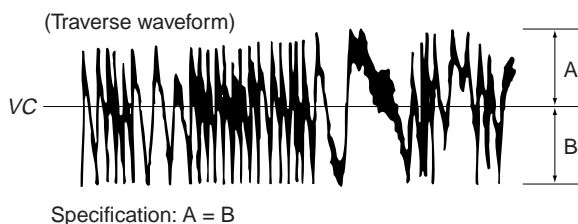

18. Press the  $\llbracket \text{YES} \rrbracket$  button to save the adjustment results in the non-volatile memory. (At this time “EFB =  $\square \square$  SAV” is displayed for a moment)  
 Then, “EF CD ADJUS” appears and the disc stops rotating automatically.  
 19. Press the  $\llbracket \text{EJECT} \rrbracket$  button to eject the check disc.

## 5-12. Focus Bias Adjustment

Adjustment procedure:

- Load the test disc (MDW-74/AU-1).  
The disc is loaded by pushing the tray.
- Rotate the  $\llbracket \llcorner \llcorner \text{AMS} \gg \gg \rrbracket$  knob to display “CPLAY MODE” (C30).
- Press the  $\llbracket \text{YES} \rrbracket$  button to display “CPLAY MID”.
- After “C =  $\square \square \square \square$  AD =  $\square \square$ ” appears, press the  $\llbracket \text{MENU/NO} \rrbracket$  button.
- Rotate the  $\llbracket \llcorner \llcorner \text{AMS} \gg \gg \rrbracket$  knob to display “FBIAS CHECK” (C13).
- Press the  $\llbracket \text{YES} \rrbracket$  button to display “ $\square \square \square \square / \square \square$  a =  $\square \square$ ”.  
The first four digits indicate the C1 error rate, the two digits after “/” indicate ADER, and the two digits after “a =” indicate the focus bias amount.
- Rotate the  $\llbracket \llcorner \llcorner \text{AMS} \gg \gg \rrbracket$  knob in the clockwise direction and find the focus bias amount at which the C1 error rate becomes approx. 200. (Refer to Note 2.)
- Press the  $\llbracket \text{YES} \rrbracket$  button to display “ $\square \square \square \square / \square \square$  b =  $\square \square$ ”.
- Rotate the  $\llbracket \llcorner \llcorner \text{AMS} \gg \gg \rrbracket$  knob in the counterclockwise direction and find the focus bias amount at which the C1 error rate becomes approx. 200. (Refer to Note 2.)  
Adjust the  $\llbracket \llcorner \llcorner \text{AMS} \gg \gg \rrbracket$  knob so that the C1 error rate becomes almost same value as the value set in step 7.
- Press the  $\llbracket \text{YES} \rrbracket$  button to display “ $\square \square \square \square / \square \square$  c =  $\square \square$ ”.
- Confirm that the C1 error rate is below 50 and the ADER is 00 and press the  $\llbracket \text{YES} \rrbracket$  button.
- If “(  $\square \square$  )” of “ $\square \square - \square \square$  (  $\square \square$  )” is above 20, press the  $\llbracket \text{YES} \rrbracket$  button.  
If it is below 20, press the  $\llbracket \text{MENU/NO} \rrbracket$  button and perform the adjustment from the step 2 again.
- Press the  $\llbracket \text{EJECT} \rrbracket$  button to eject the test disc.

**Note 1:** The relation between the C1 error and focus bias is as shown in the following figure. Find points a and b in the following figure using the above adjustment. The focal point position C is automatically calculated from points a and b.

**Note 2:** As the C1 error rate changes, perform the adjustment using the average value.

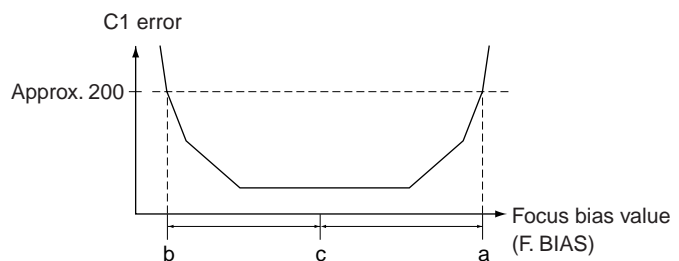



### 5-13. Error Rate Check

#### 5-13-1. CD Error Rate Check

Checking procedure:

1. Load a check disc (TDYS-1).  
The disc is loaded by pushing the tray.
2. Rotate the [◀◀AMS▶▶] knob to display "CPLAY MODE" (C30).
3. Press the [YES] button to display "CPLAY MID".
4. The display is changed to "C = 0000AD = 00".
5. Confirm that the C1 error rate is below 20.
6. Press the [MENU/NO] button to stop playing back, and press the [⏏] button to eject the check disc.

#### 5-13-2. MO Error Rate Check

Checking procedure:

1. Load a test disc (MDW-74/AU-1).  
The disc is loaded by pushing the tray.
2. Rotate the [◀◀AMS▶▶] knob to display "CPLAY MODE" (C30).
3. Press the [YES] button to display "CPLAY MID".
4. The display is changed to "C = 0000AD = 00".
5. Confirm that the C1 error rate is below 50 and the ADER is below 2.
6. Press the [MENU/NO] button to stop playing back, and press the [⏏] button to eject the test disc.

#### 5-14. Focus Bias Check

Change the focus bias to check the focus tolerance amount.

Checking procedure:

1. Load the test disc (MDW-74/AU-1).  
The disc is loaded by pushing the tray.
2. Rotate the [◀◀AMS▶▶] knob to display "CPLAY MODE" (C30).
3. Press the [YES] button to display "CPLAY MID".
4. After "C = 0000AD = 00" appears, press the [MENU/NO] button.
5. Rotate the [◀◀AMS▶▶] knob to display "FBIAS CHECK" (C05).
6. Press the [YES] button to display "0000/00c = 00".  
The first four digits indicate the C1 error rate, the two digits after "/" indicate ADER, and the two digits after "c =" indicate the focus bias amount.  
Confirm that the C1 error is below 50 and the ADER is below 2.
7. Press the [YES] button to change the display to "0000 / 00b = 00".  
Confirm that the C1 error is below 200 and the ADER is below 2.
8. Press the [YES] button to change the display to "0000 / 00a = 00".  
Confirm that the C1 error is below 200 and the ADER is below 2.

9. Press the [MENU/NO] button and press the [⏏] button to eject the test disc.

**Note 1 :** If the C1 error and ADER are out of the specified value at points a (step 8) or b (step 7), the focus bias adjustment may not have been carried out properly. Perform the adjustment from the beginning again.

#### 5-15. Auto Gain Control Output Level Adjustment

Be sure to perform this adjustment when optical pickup is replaced. When result of adjustment ends with the message "Adjust NG!", the optical pickup may be defective. Perform the adjustment again.

##### 5-15-1. CD Auto Gain Control Output Level Adjustment

Adjustment procedure:

1. Load the test disc (TDYS-1).  
The disc is loaded by pushing the tray.
2. Rotate the [◀◀AMS▶▶] knob to display "AG Set (CD)" (C26).
3. Press the [YES] button to start automatic adjustment. After the adjustment results are saved in the non-volatile memory and "Complete!" appears, the display is changed to "AG Set (CD)" and the adjustments are completed.
4. Press the [MENU/NO] button and press the [⏏] button to eject the check disc.

##### 5-15-2. MO Auto Gain Control Output Level Adjustment

Adjustment procedure:

1. Load the test disc (MDW-74/AU-1).  
The disc is loaded by pushing the tray.
2. Rotate the [◀◀AMS▶▶] knob to display "AG Set (MO)" (C25).
3. Press the [YES] button to start automatic adjustment. After the adjustment results are saved in the non-volatile memory and "Complete!" appears, the display is changed to "AG Set (MO)" and the adjustments are completed.
4. Press the [MENU/NO] button and press the [⏏] button to eject the check disc.

### 5-16. Adjusting Points and Connecting Points

[BD BOARD] (SIDE A)

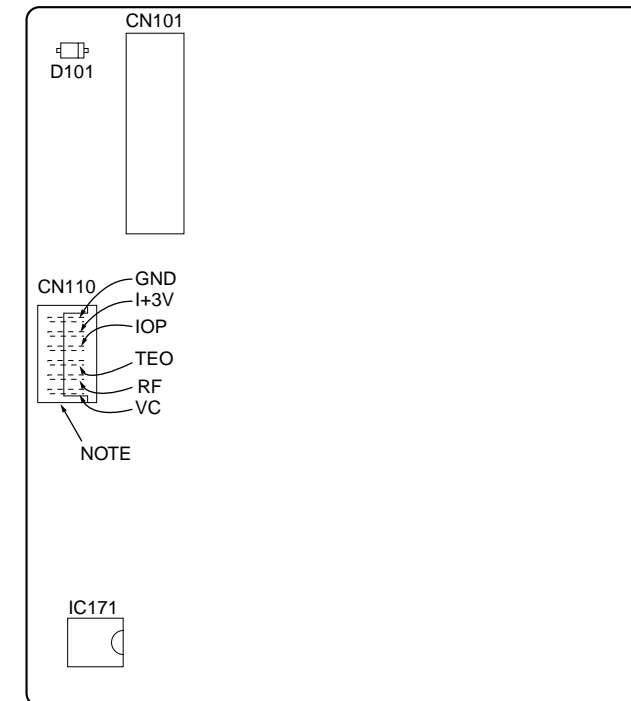

**Note:** It is recommended to use the tool for BD board waveform check when the waveform is checked. (Refer to page 7 of Service note.)

[BD BOARD] (SIDE B)

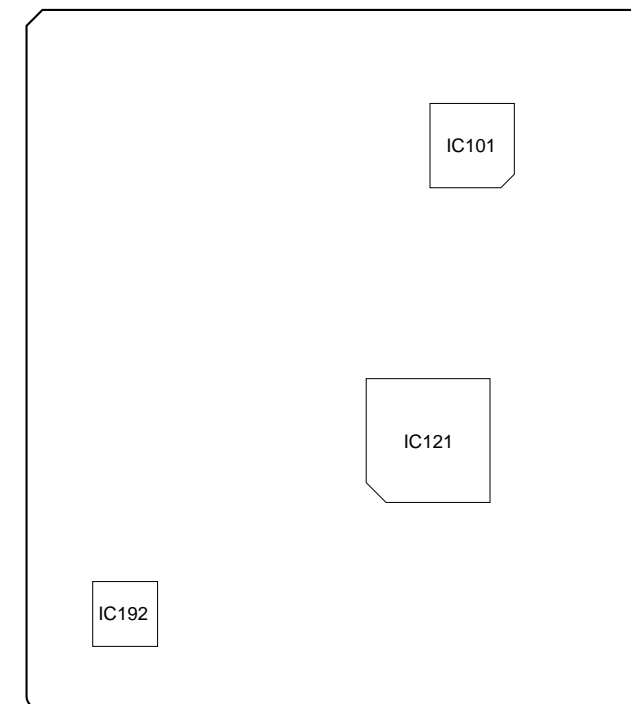

SECTION 6  
DIAGRAMS

6-1. BLOCK DIAGRAMS  
BD SECTION

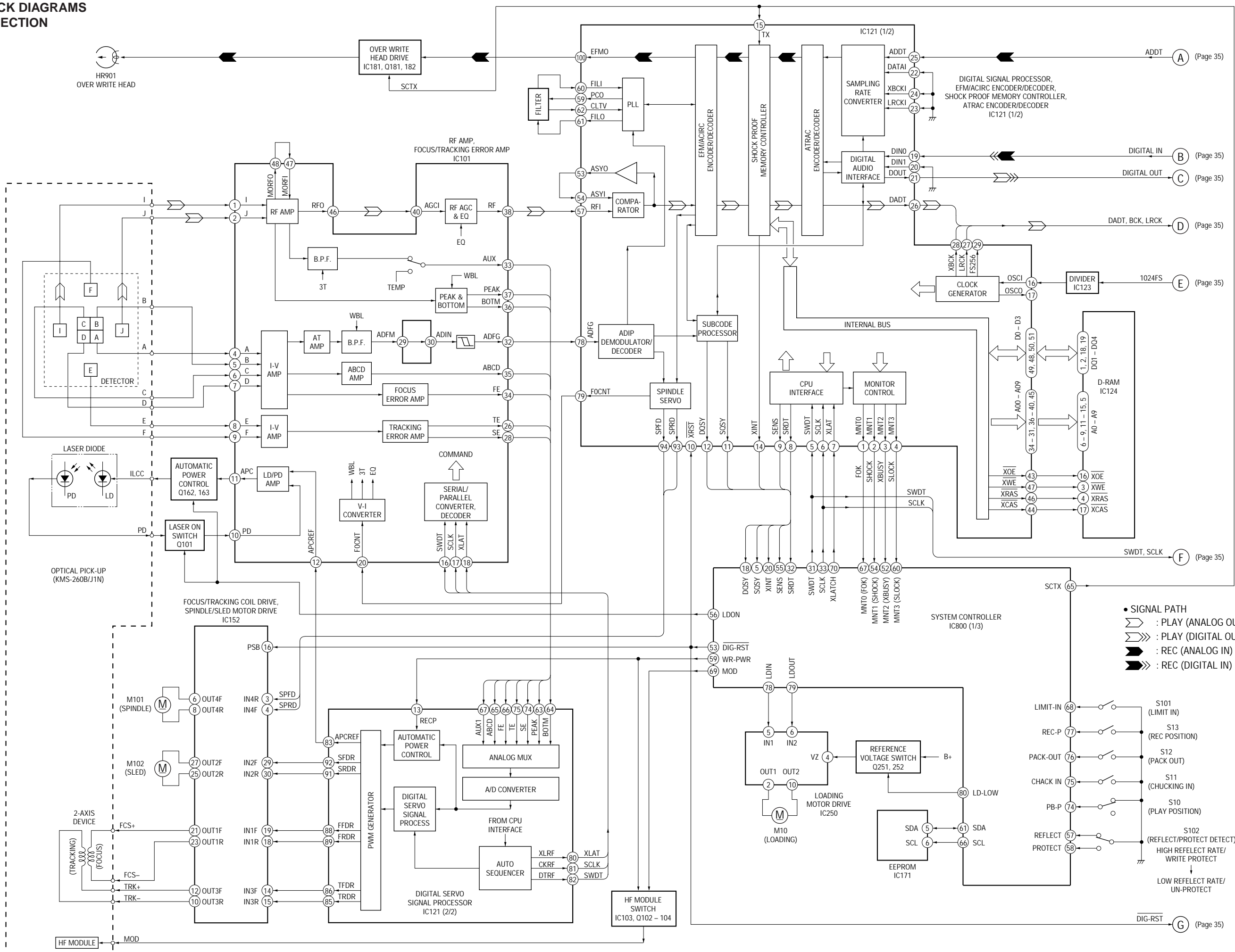

- SIGNAL PATH
- : PLAY (ANALOG OUT)
- : PLAY (DIGITAL OUT)
- : REC (ANALOG IN)
- : REC (DIGITAL IN)

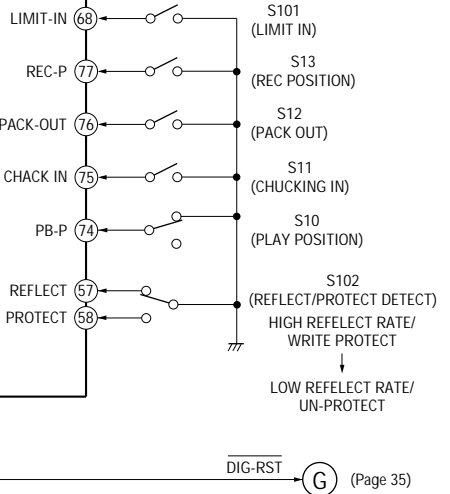

MAIN SECTION

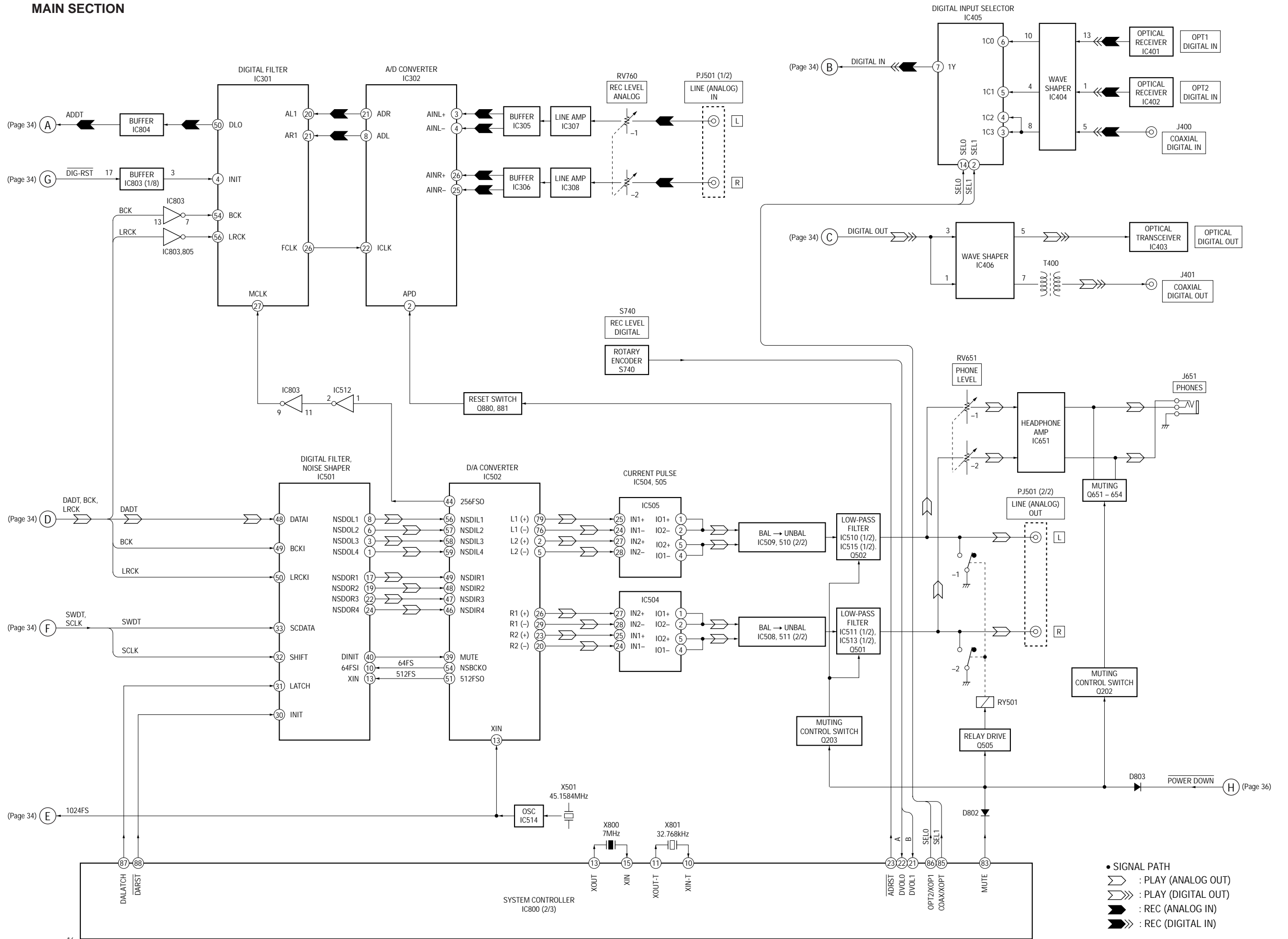

- SIGNAL PATH
- ▷ : PLAY (ANALOG OUT)
- ▷▷ : PLAY (DIGITAL OUT)
- ◁ : REC (ANALOG IN)
- ◁◁ : REC (DIGITAL IN)

DISPLAY/POWER SUPPLY SECTION

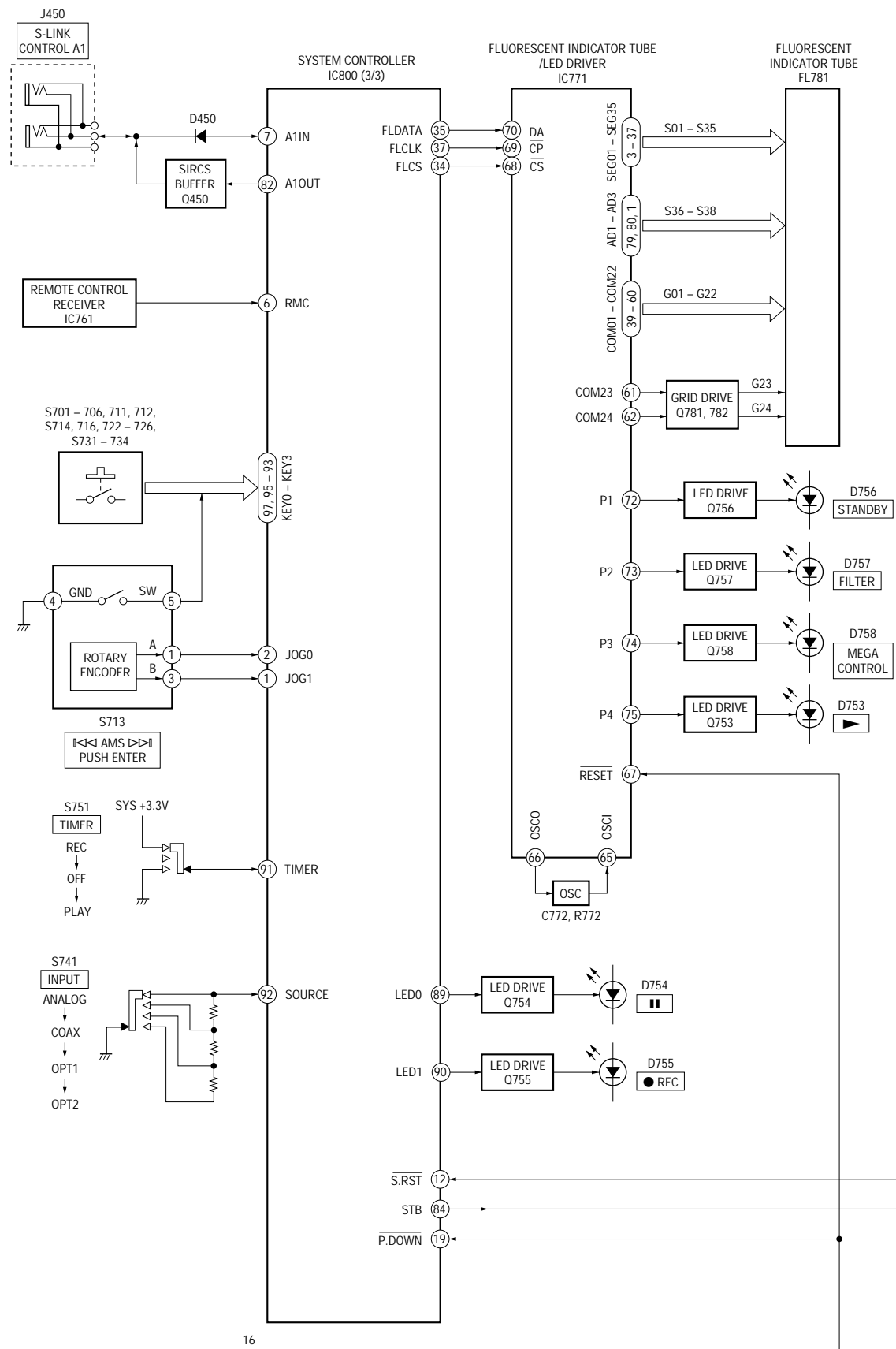

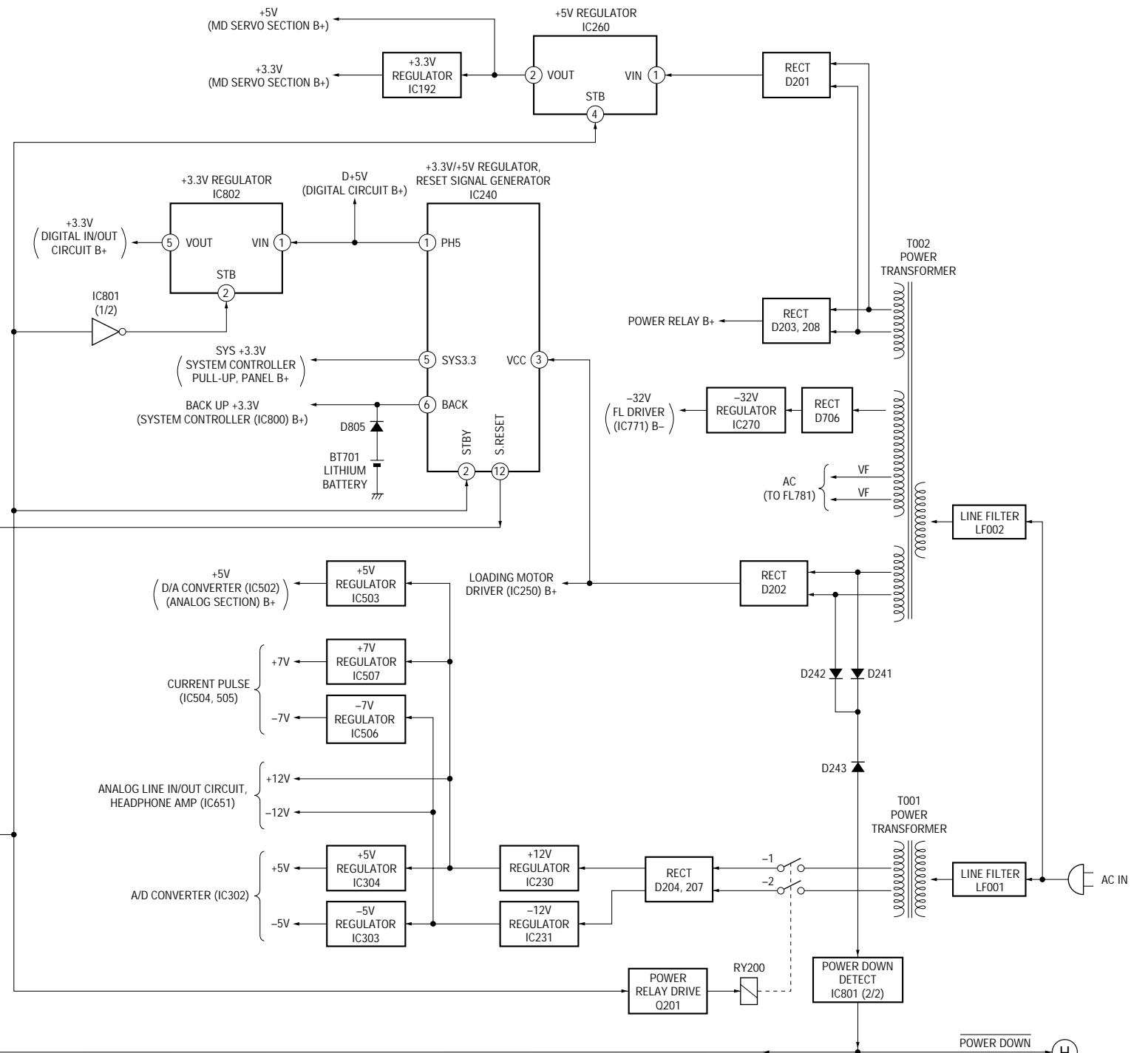

16



THIS NOTE IS COMMON FOR PRINTED WIRING BOARDS AND SCHEMATIC DIAGRAMS.  
(In addition to this, the necessary note is printed in each block.)

**Note on Schematic Diagram:**







- All capacitors are in  $\mu\text{F}$  unless otherwise noted. pF:  $\mu\mu\text{F}$  50 WV or less are not indicated except for electrolytics and tantalums.
- All resistors are in  $\Omega$  and  $1/4\text{ W}$  or less unless otherwise specified.
- $\Delta$  : internal component.
-  : nonflammable resistor.
-  : fusible resistor.
-  : panel designation.

**Note:**



The components identified by mark  $\Delta$  or dotted line with mark  $\Delta$  are critical for safety. Replace only with part number specified.

**Note:**

Les composants identifiés par une marque  $\Delta$  sont critiques pour la sécurité. Ne les remplacer que par une pièce portant le numéro spécifié.

-  : B+ Line.
-  : B- Line.
- Voltages are taken with a VOM (Input impedance 10 M $\Omega$ ). Voltage variations may be noted due to normal production tolerances.
- Waveforms are taken with a oscilloscope. Voltage variations may be noted due to normal production tolerances.
- Signal path.
  -  : PB
  -  : REC
  -  : PB (DIGITAL)
  -  : REC (DIGITAL)

**Note on Printed Wiring Boards:**

-  : parts extracted from the component side.
-  : parts extracted from the conductor side.
-  : Pattern from the side which enables seeing. (The other layers' patterns are not indicated.)

**Caution:**

Pattern face side: Parts on the pattern face side seen from the pattern face are indicated.  
Parts face side: Parts on the parts face side seen from the parts face are indicated.

- Indication of transistor.

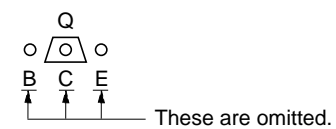
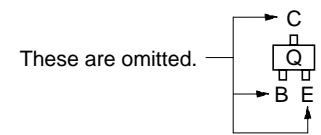

**6-2. CIRCUIT BOARD LOCATION**

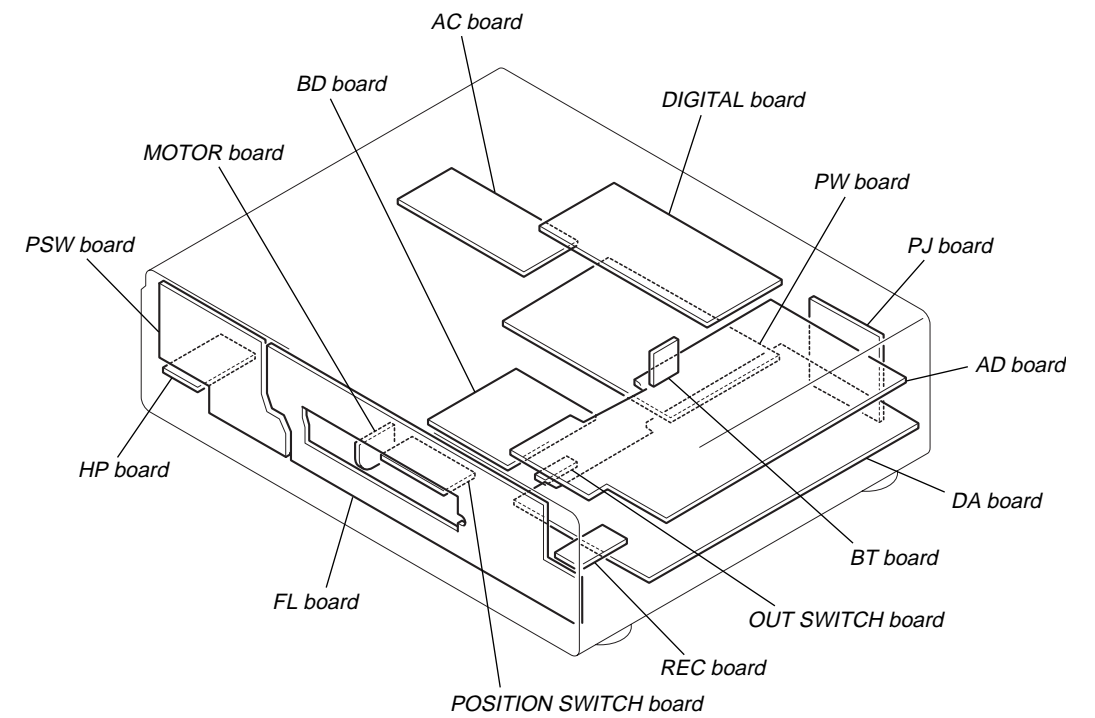

6-3. PRINTED WIRING BOARD BD SECTION • Refer to page 37 for Note on Printed Wiring Boards. • Refer to page 37 for Circuit Board Location.

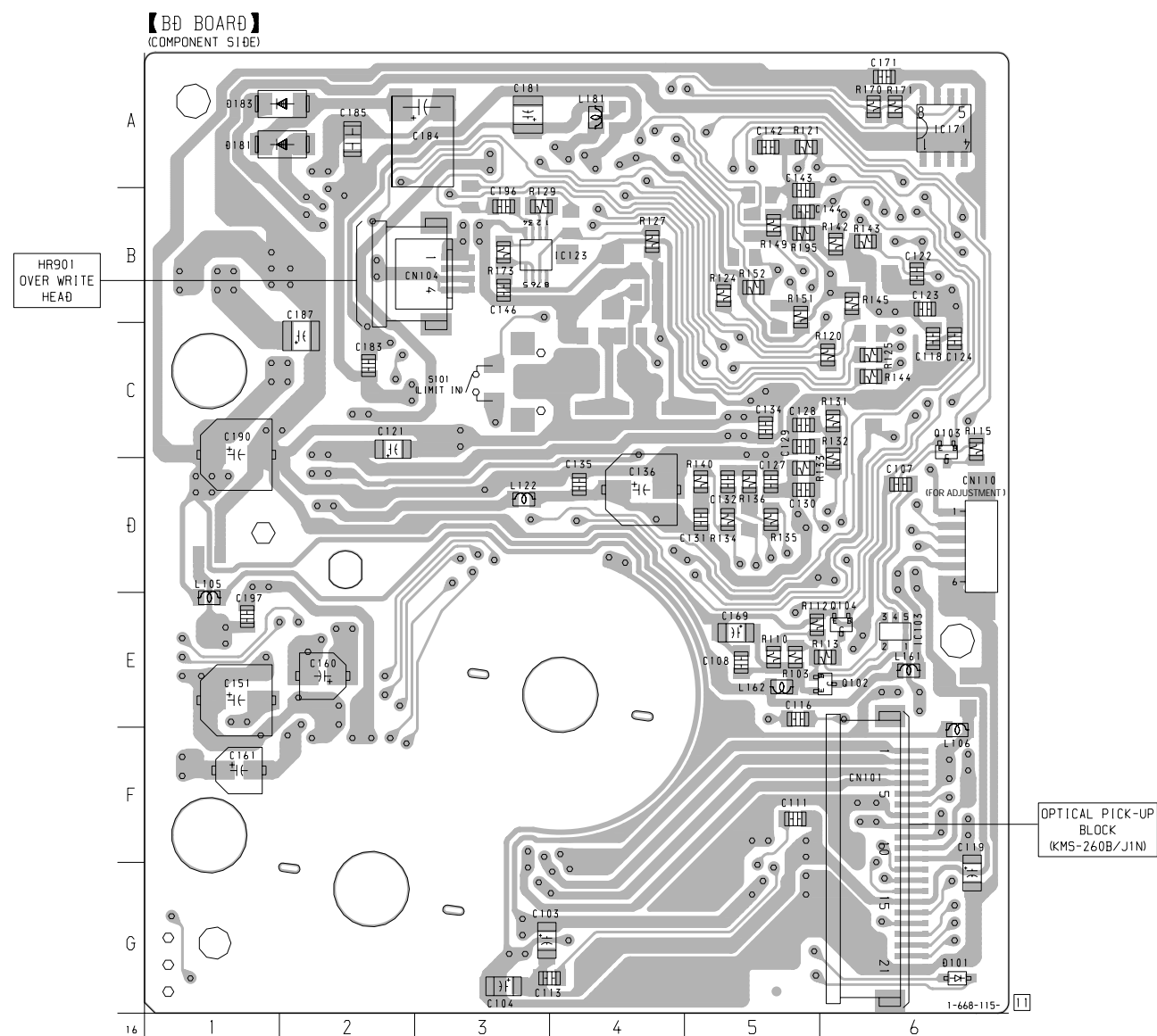

• Semiconductor Location

| Ref. No. | Location |
|----------|----------|
| D101     | G-6      |
| D181     | A-1      |
| D183     | A-1      |
| IC103    | E-6      |
| IC123    | B-3      |
| IC171    | A-6      |
| Q102     | E-5      |
| Q103     | C-6      |
| Q104     | E-6      |

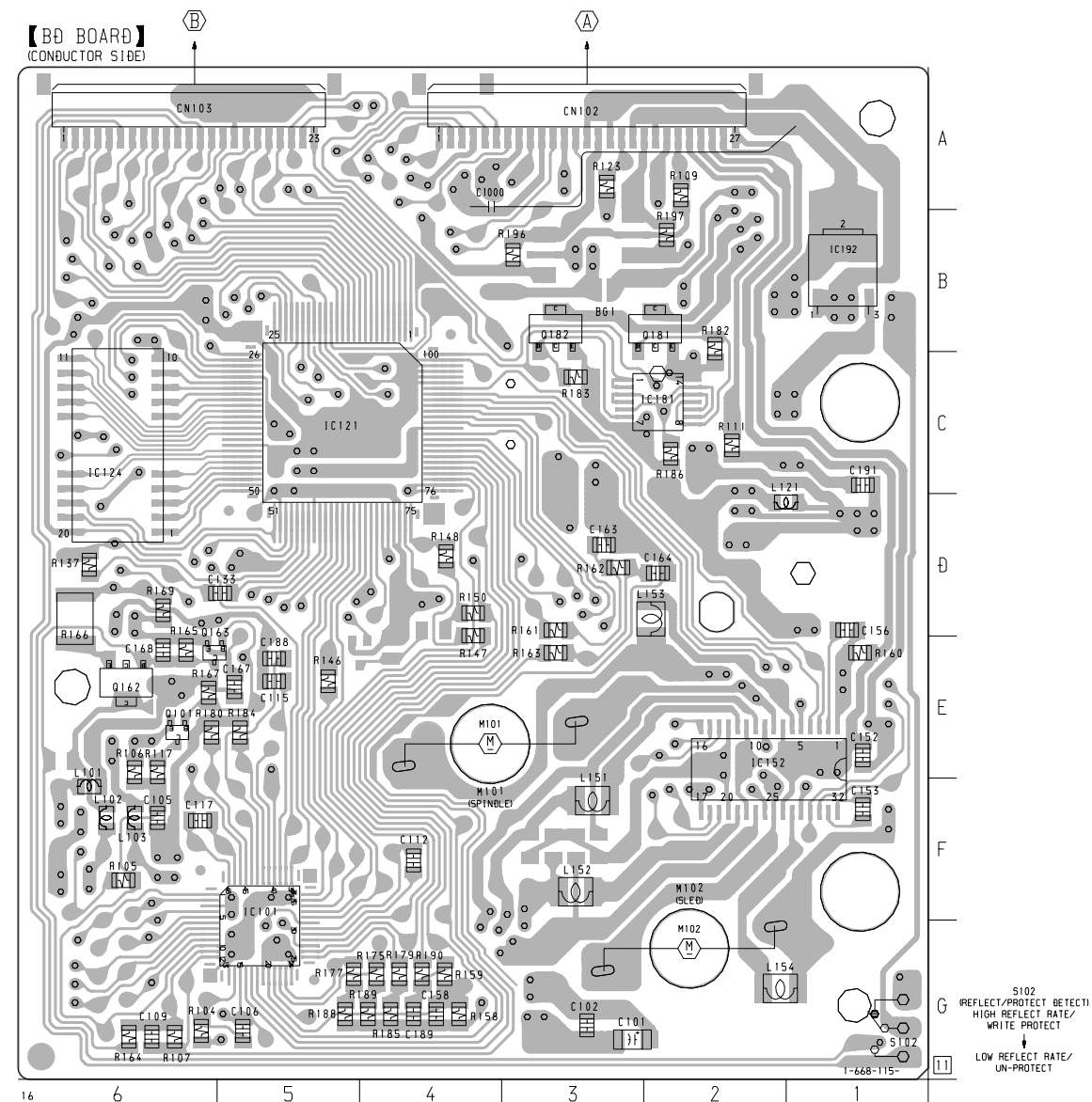

• Semiconductor Location

| Ref. No. | Location |
|----------|----------|
| IC101    | G-5      |
| IC121    | C-5      |
| IC124    | C-6      |
| IC152    | E-2      |
| IC181    | C-2      |
| IC192    | B-1      |
| Q101     | E-6      |
| Q162     | E-6      |
| Q163     | E-5      |
| Q181     | B-2      |
| Q182     | B-3      |

6-4. SCHEMATIC DIAGRAM BD SECTION(1/2)

• Refer to page 37 for Note on Schematic Diagrams. • Refer to page 56 for Waveforms.  
 • Refer to page 58 for IC Block Diagram. • Refer to page 63 for IC Pin Function.

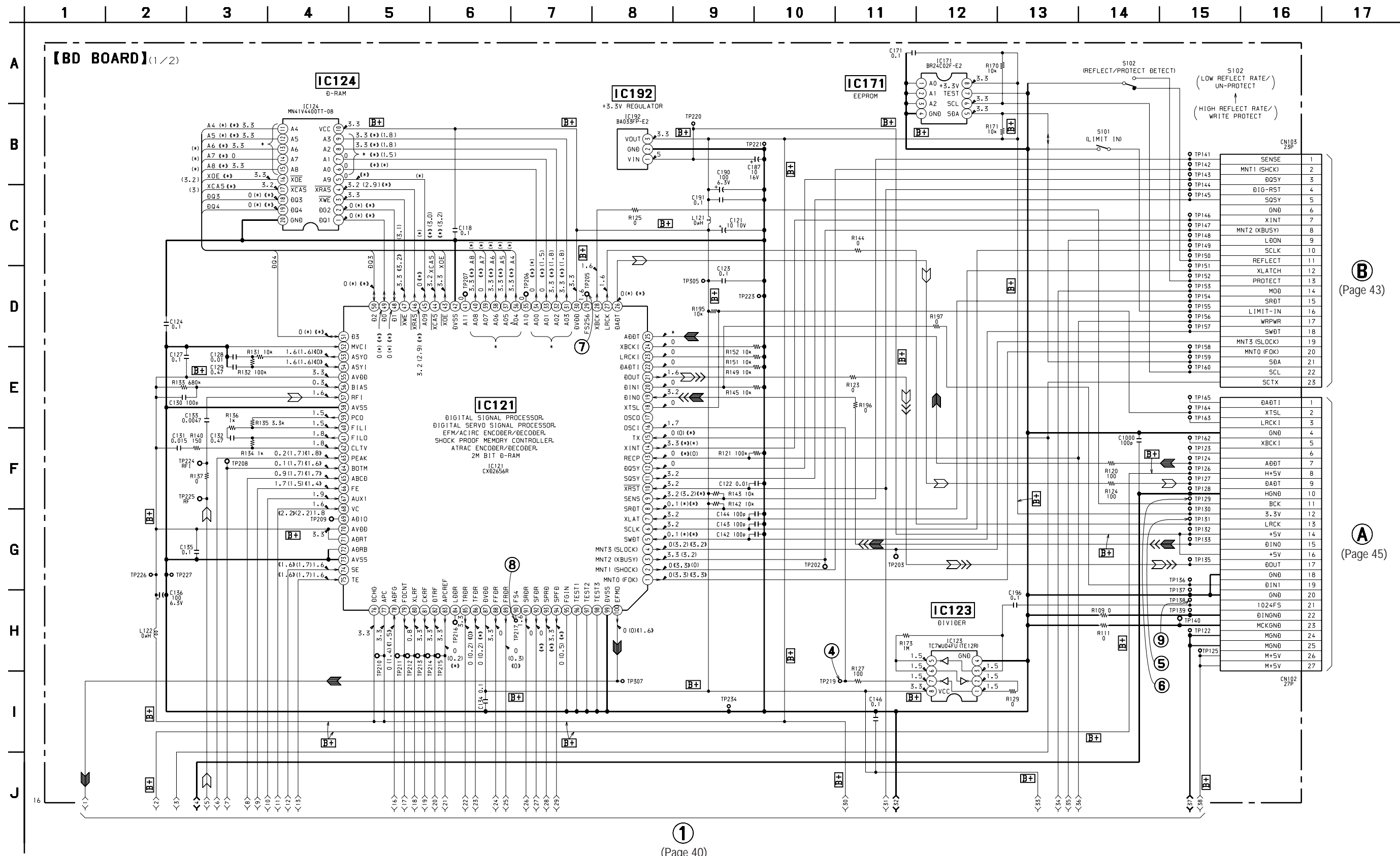

(B)  
 (Page 43)

(A)  
 (Page 45)

①  
 (Page 40)

6-5. SCHEMATIC DIAGRAM BD SECTION(2/2)

- Refer to page 37 for Note on Schematic Diagrams.
- Refer to page 56 for Waveforms.
- Refer to page 57 for IC Block Diagram.
- Refer to page 62 for IC Pin Function.

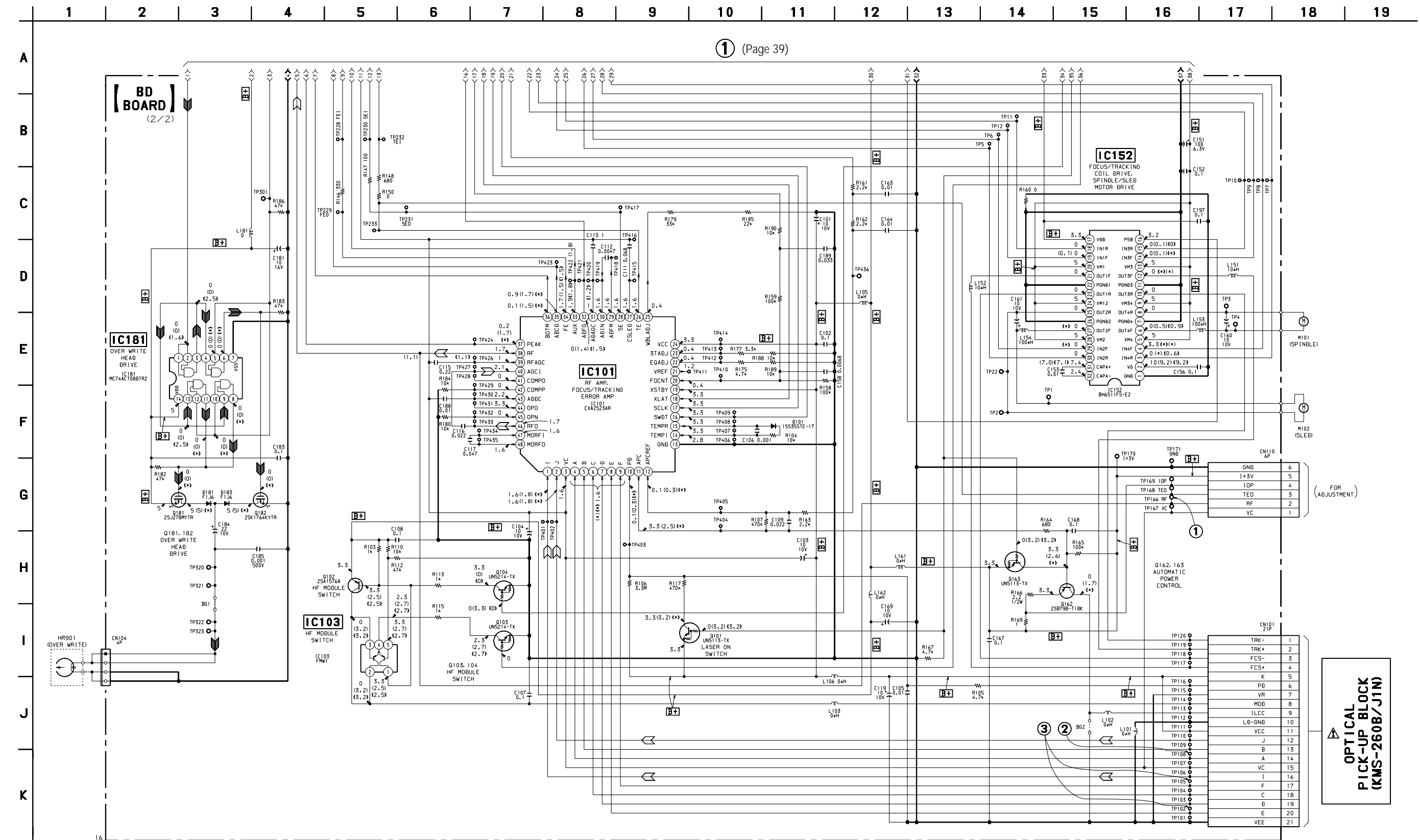

The components identified by mark  $\Delta$  or dotted line with mark  $\Delta$  are critical for safety. Replace only with part number specified.

Les composants identifiés par une marque  $\Delta$  sont critiques pour la sécurité. Ne les remplacer que par une pièce portant le numéro spécifié.



6-6. SCHEMATIC DIAGRAM BD SWITCH SECTION • Refer to page 37 for Note on Schematic Diagrams.

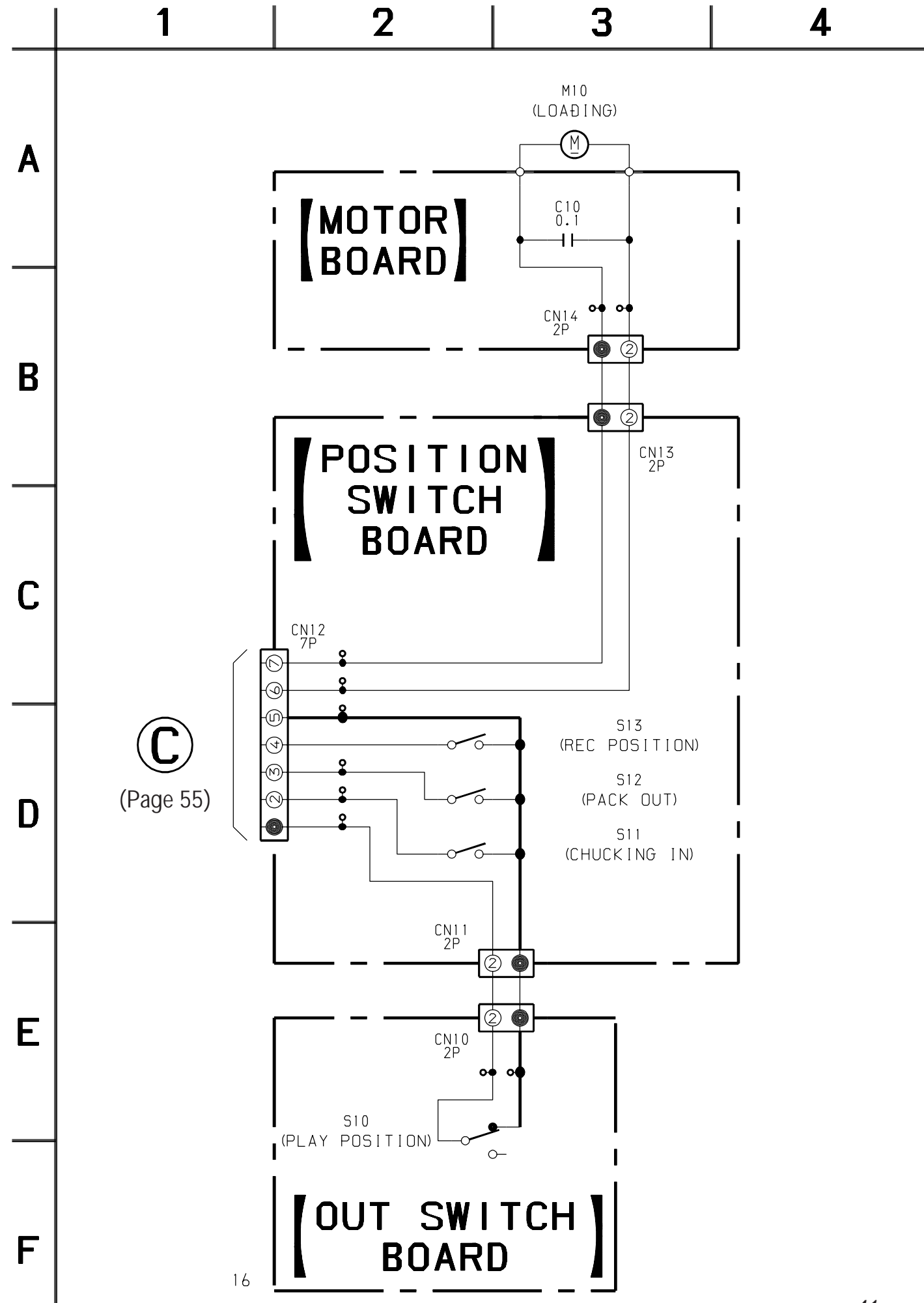

6-7. PRINTED WIRING BOARD BD SWITCH SECTION • Refer to page 37 for Note on Printed Wiring Boards.  
• Refer to page 37 for Circuit Board Location.

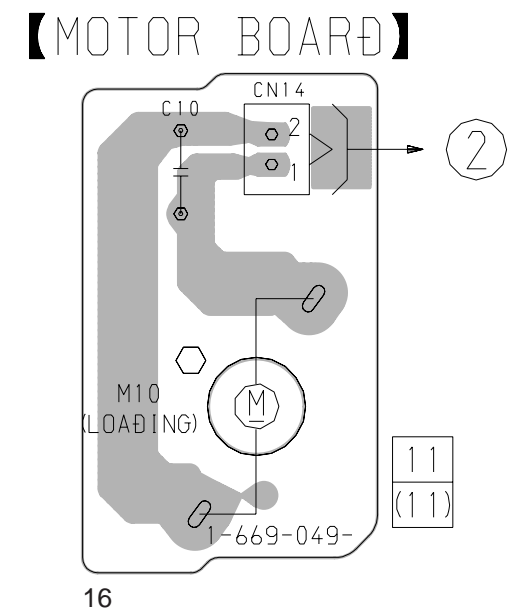
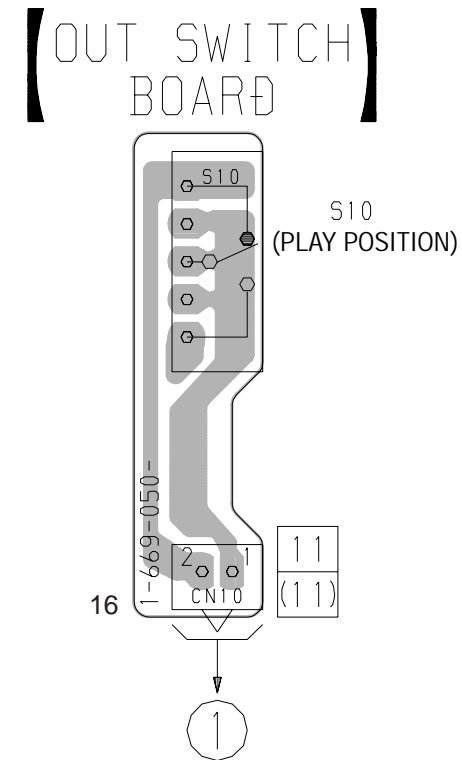
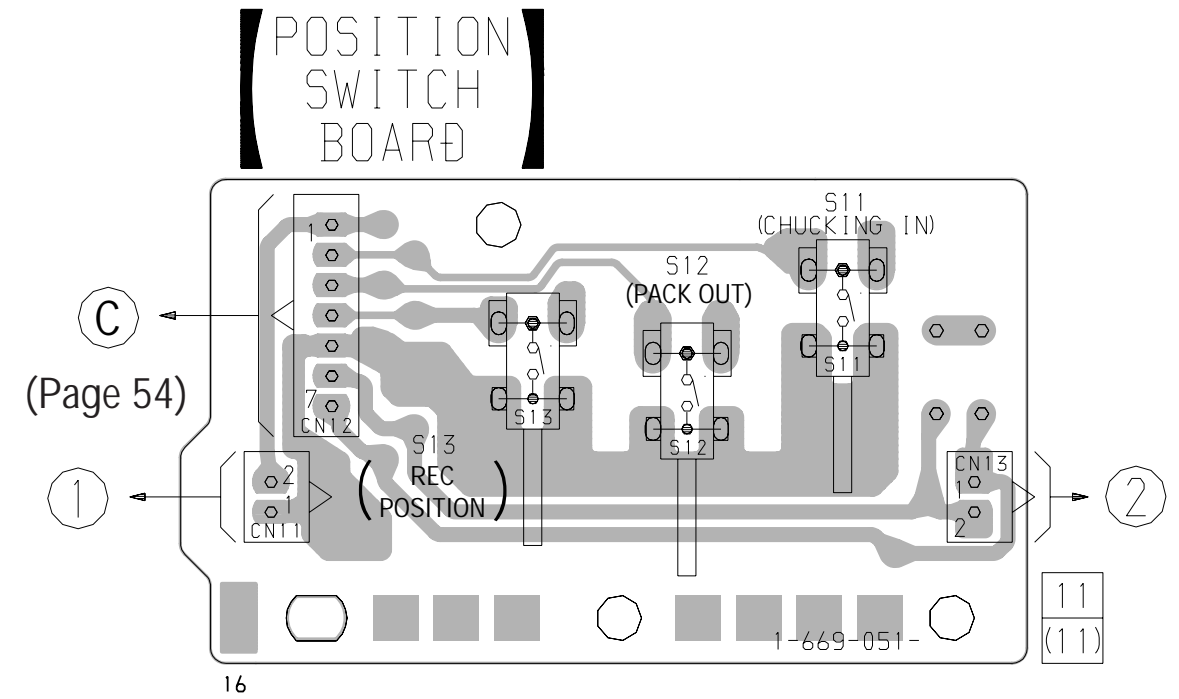

6-8. PRINTED WIRING BOARD AD SECTION • Refer to page 37 for Note on Printed Wiring Boards. • Refer to page 37 for Circuit Board Location.

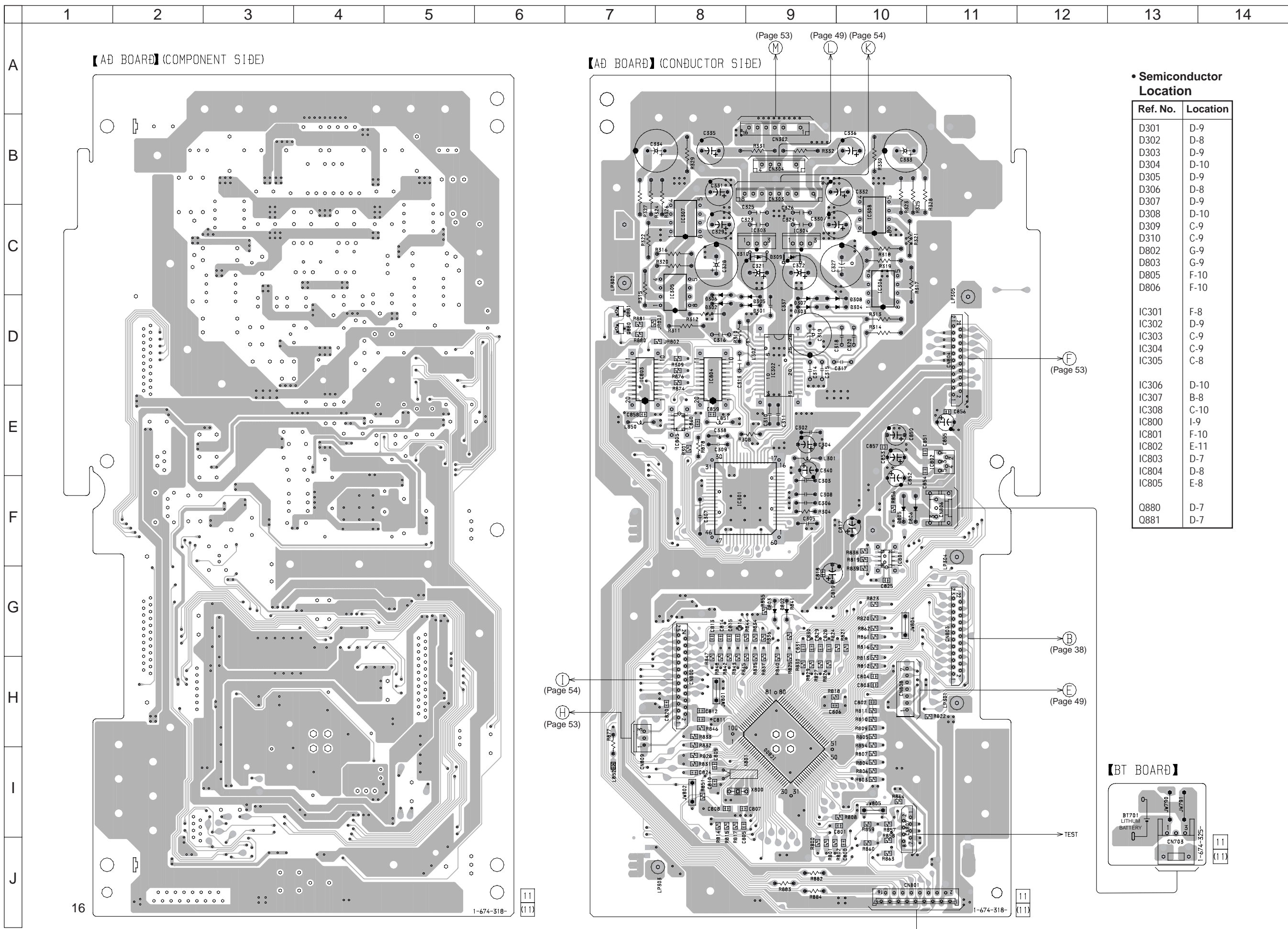

• Semiconductor Location

| Ref. No. | Location |
|----------|----------|
| D301     | D-9      |
| D302     | D-8      |
| D303     | D-9      |
| D304     | D-10     |
| D305     | D-9      |
| D306     | D-8      |
| D307     | D-9      |
| D308     | D-10     |
| D309     | C-9      |
| D310     | C-9      |
| D802     | G-9      |
| D803     | G-9      |
| D805     | F-10     |
| D806     | F-10     |
| IC301    | F-8      |
| IC302    | D-9      |
| IC303    | C-9      |
| IC304    | C-9      |
| IC305    | C-8      |
| IC306    | D-10     |
| IC307    | B-8      |
| IC308    | C-10     |
| IC800    | I-9      |
| IC801    | F-10     |
| IC802    | E-11     |
| IC803    | D-7      |
| IC804    | D-8      |
| IC805    | E-8      |
| Q880     | D-7      |
| Q881     | D-7      |

【BT BOARD】

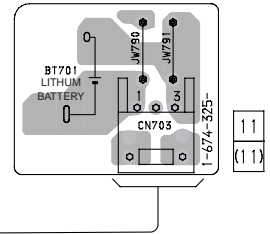

6-9. SCHEMATIC DIAGRAM AD SECTION(1/2) • Refer to page 37 for Note on Schematic Diagrams. • Refer to page 56 for Waveforms. • Refer to page 68 for IC Pin Function.

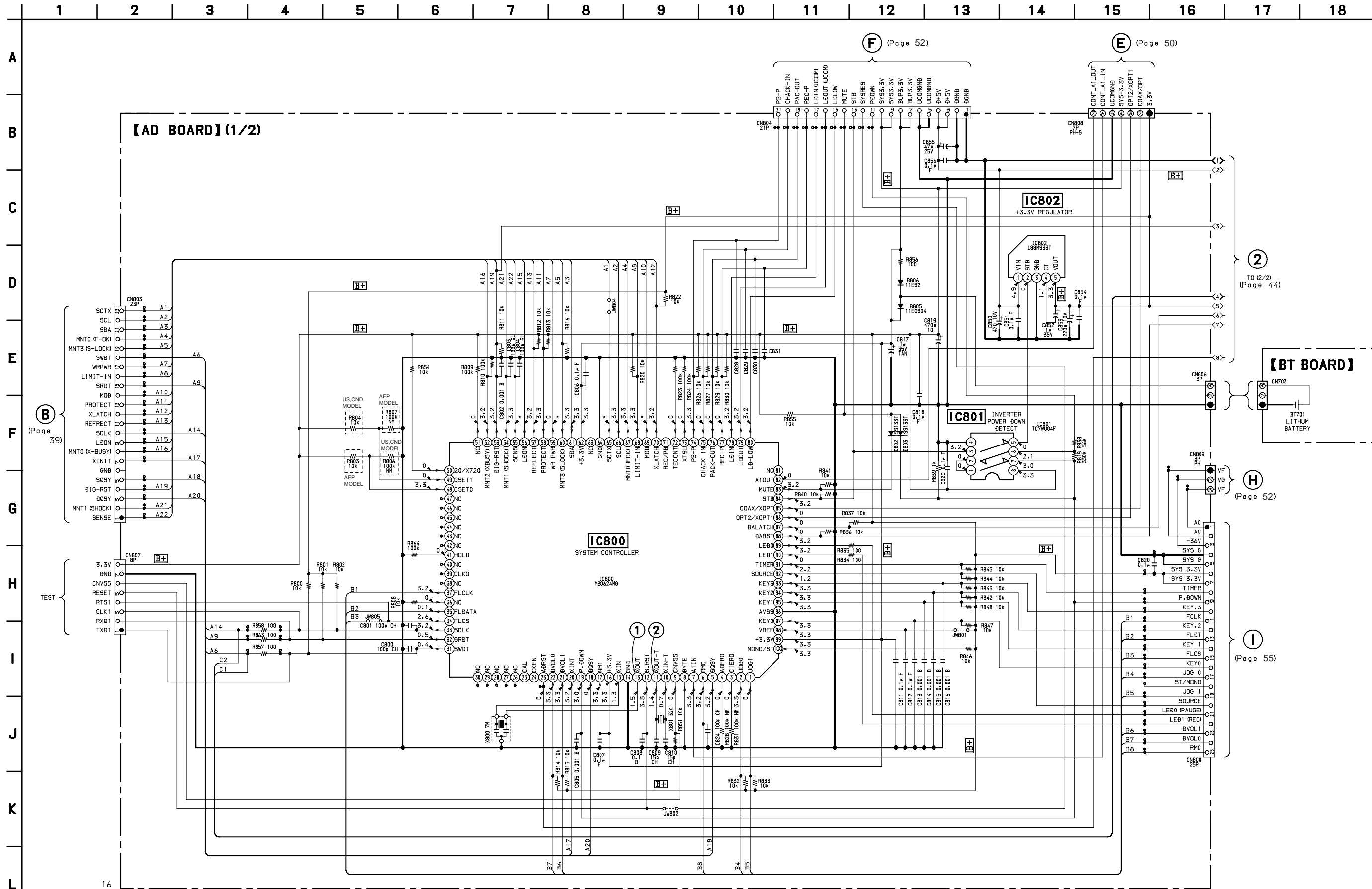

**NOTE**  
 • Voltages and waveforms are dc with respect to ground under no-signal conditions.  
 no mark: PLAY

6-10. SCHEMATIC DIAGRAM AD SECTION(2/2) • Refer to page 37 for Note on Schematic Diagrams. • Refer to page 56 for Waveforms.  
 • Refer to page 59 for IC Block Diagrams. • Refer to page 66 for IC Pin Function.

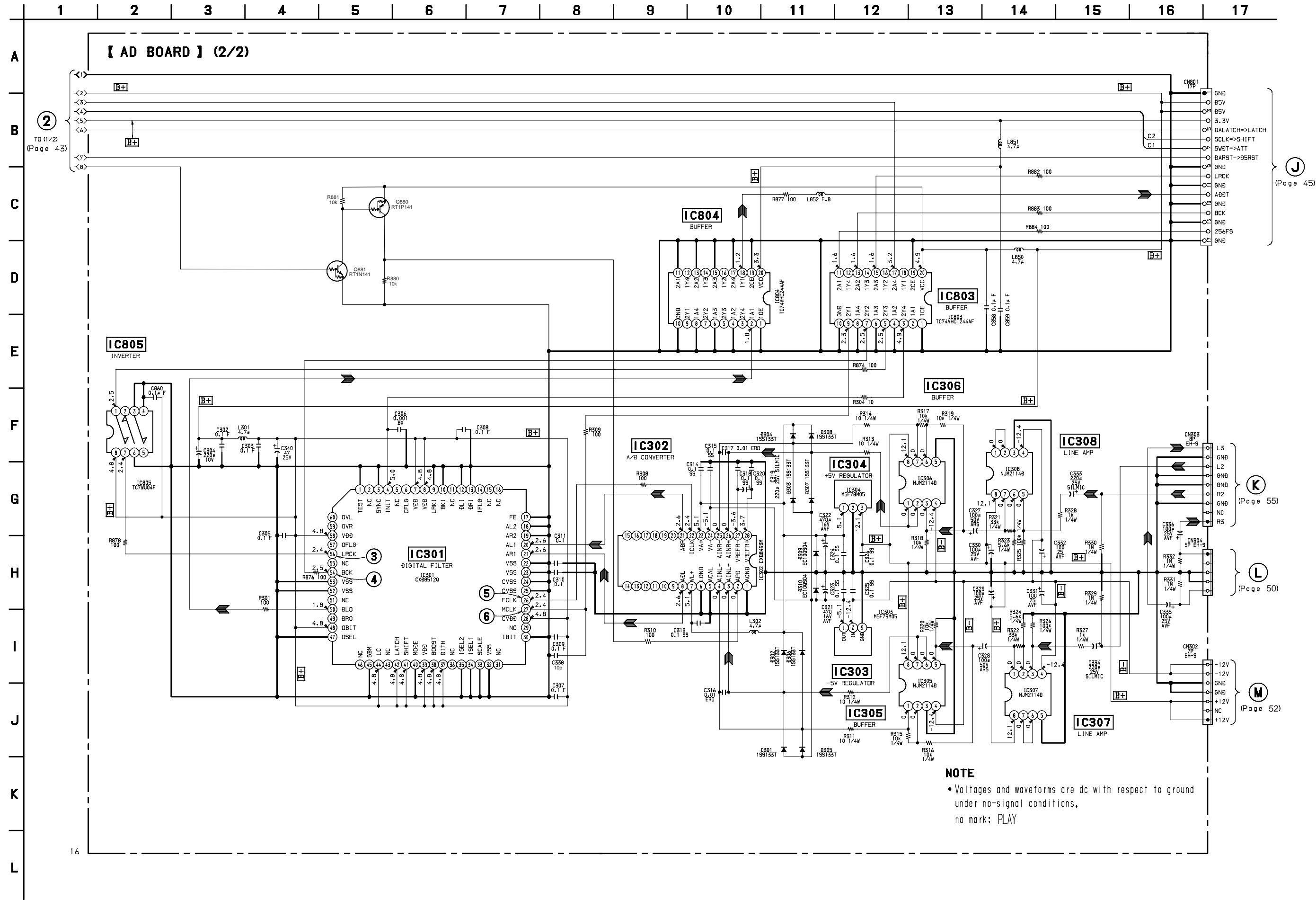

**NOTE**  
 • Voltages and waveforms are dc with respect to ground under no-signal conditions.  
 no mark: PLAY

(Page 45)

(Page 55)

(Page 50)

(Page 52)

6-11. SCHEMATIC DIAGRAM DA SECTION(1/2) • Refer to page 37 for Note on Schematic Diagrams. • Refer to page 56 for Waveforms. • Refer to page 59 for IC Block Diagrams.

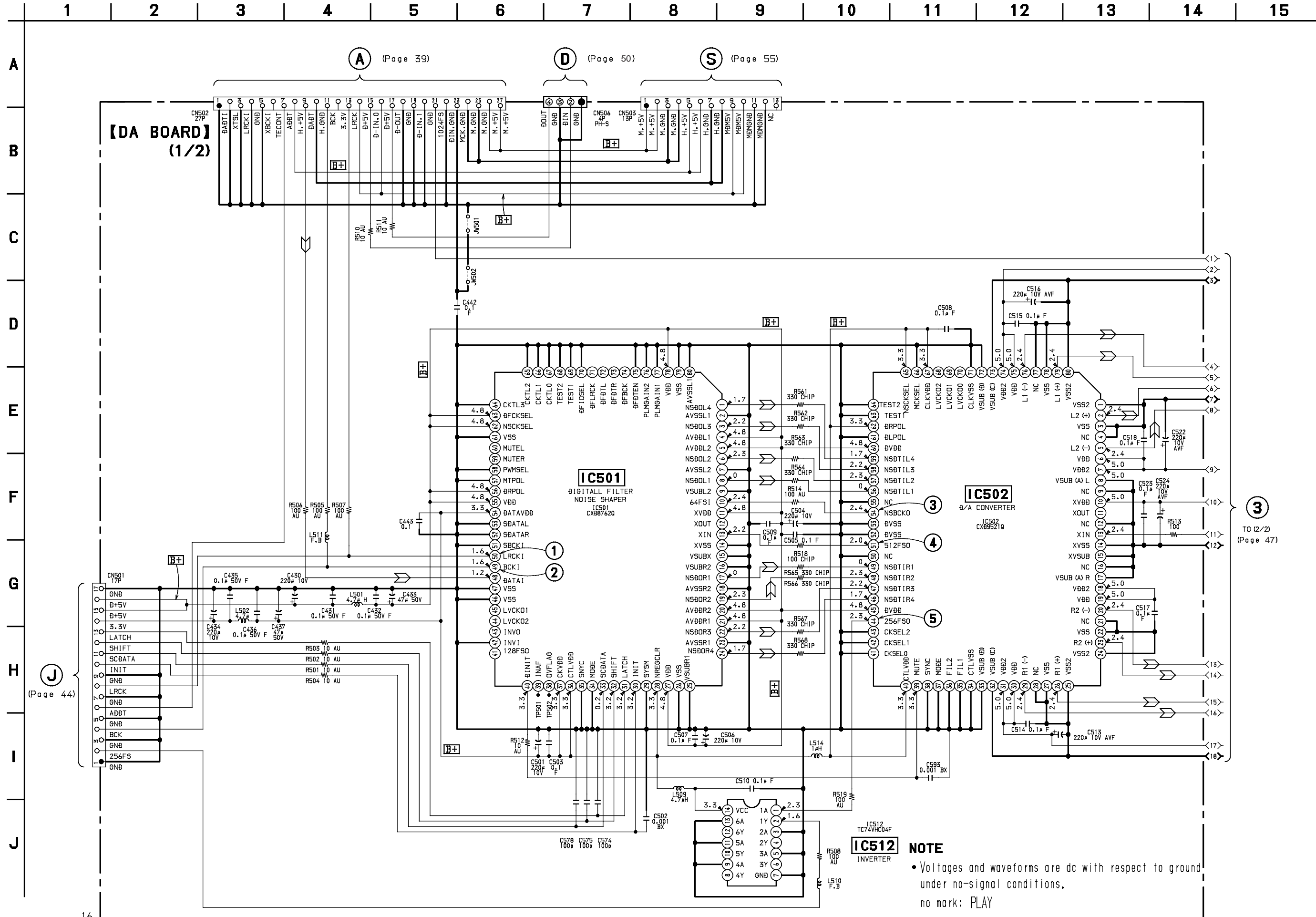

TO (2/2)  
(Page 47)

**NOTE**  
• Voltages and waveforms are dc with respect to ground under no-signal conditions.  
no mark: PLAY

6-12. PRINTED WIRING BOARD DA SECTION • Refer to page 37 for Note on Printed Wiring Boards. • Refer to page 37 for Circuit Board Location.

• Semiconductor Location

| Ref. No. | Location |
|----------|----------|
| D501     | F-10     |
| D502     | F-9      |
| D503     | J-10     |
| D505     | F-11     |
| D507     | I-11     |
| D508     | I-9      |
| IC501    | B-10     |
| IC502    | D-10     |
| IC503    | F-10     |
| IC504    | E-11     |
| IC505    | E-8      |
| IC506    | F-10     |
| IC507    | F-9      |
| IC508    | G-11     |
| IC509    | G-9      |
| IC510    | H-9      |
| IC511    | H-11     |
| IC512    | C-11     |
| IC513    | H-11     |
| IC514    | E-9      |
| IC515    | H-8      |
| Q501     | I-11     |
| Q502     | H-8      |
| Q505     | J-9      |

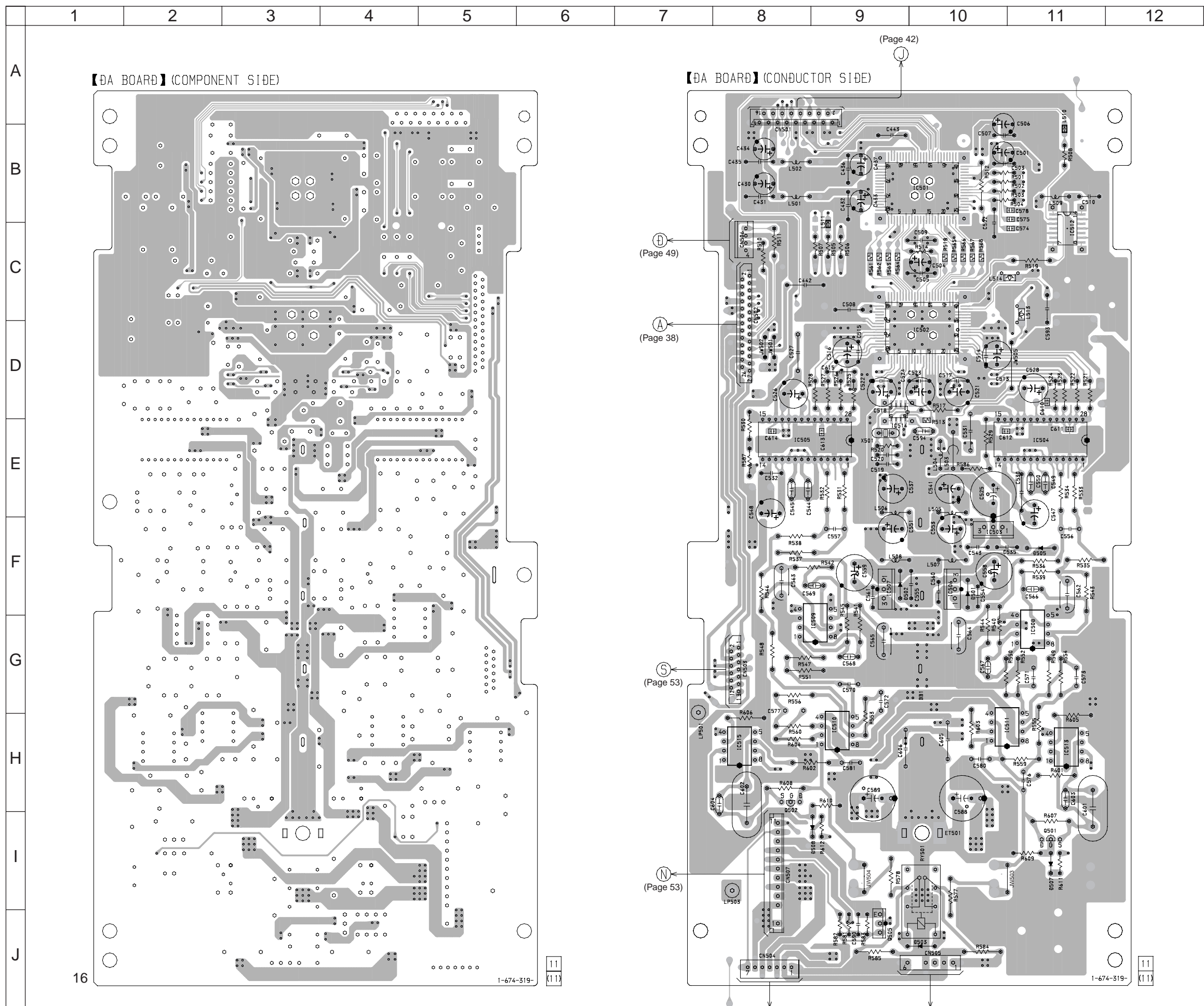

6-13. SCHEMATIC DIAGRAM DA SECTION(2/2) • Refer to page 37 for Note on Schematic Diagrams. • Refer to page 56 for Waveforms. • Refer to page 60 for IC Block Diagrams.

|   |   |   |   |   |   |   |   |   |    |    |    |    |    |    |
|---|---|---|---|---|---|---|---|---|----|----|----|----|----|----|
| 1 | 2 | 3 | 4 | 5 | 6 | 7 | 8 | 9 | 10 | 11 | 12 | 13 | 14 | 15 |
|---|---|---|---|---|---|---|---|---|----|----|----|----|----|----|

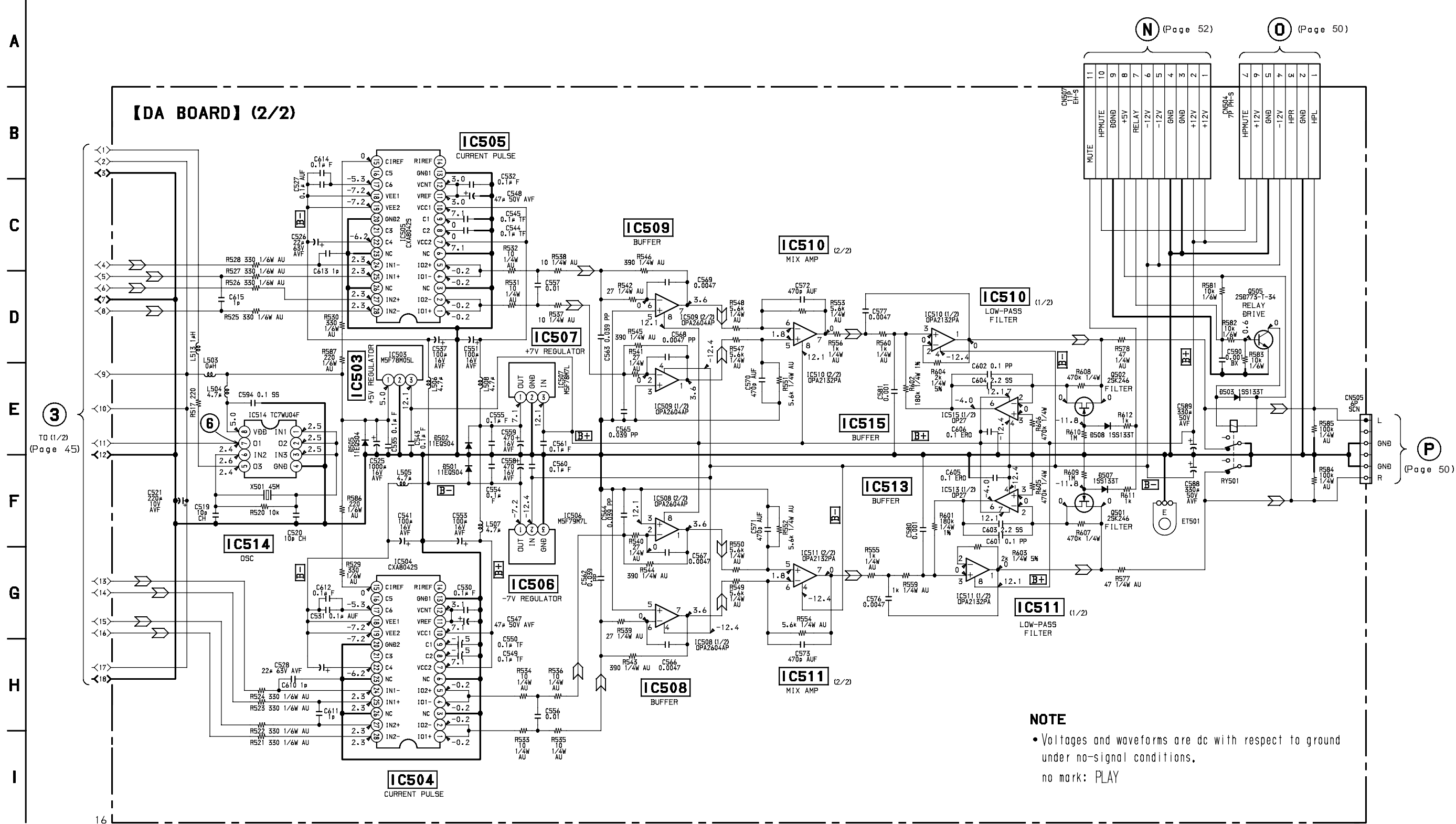

3 TO (1/2) (Page 45)

N (Page 52) O (Page 50)

P (Page 50)

【DIGITAL BOARD】 (COMPONENT SIDE)

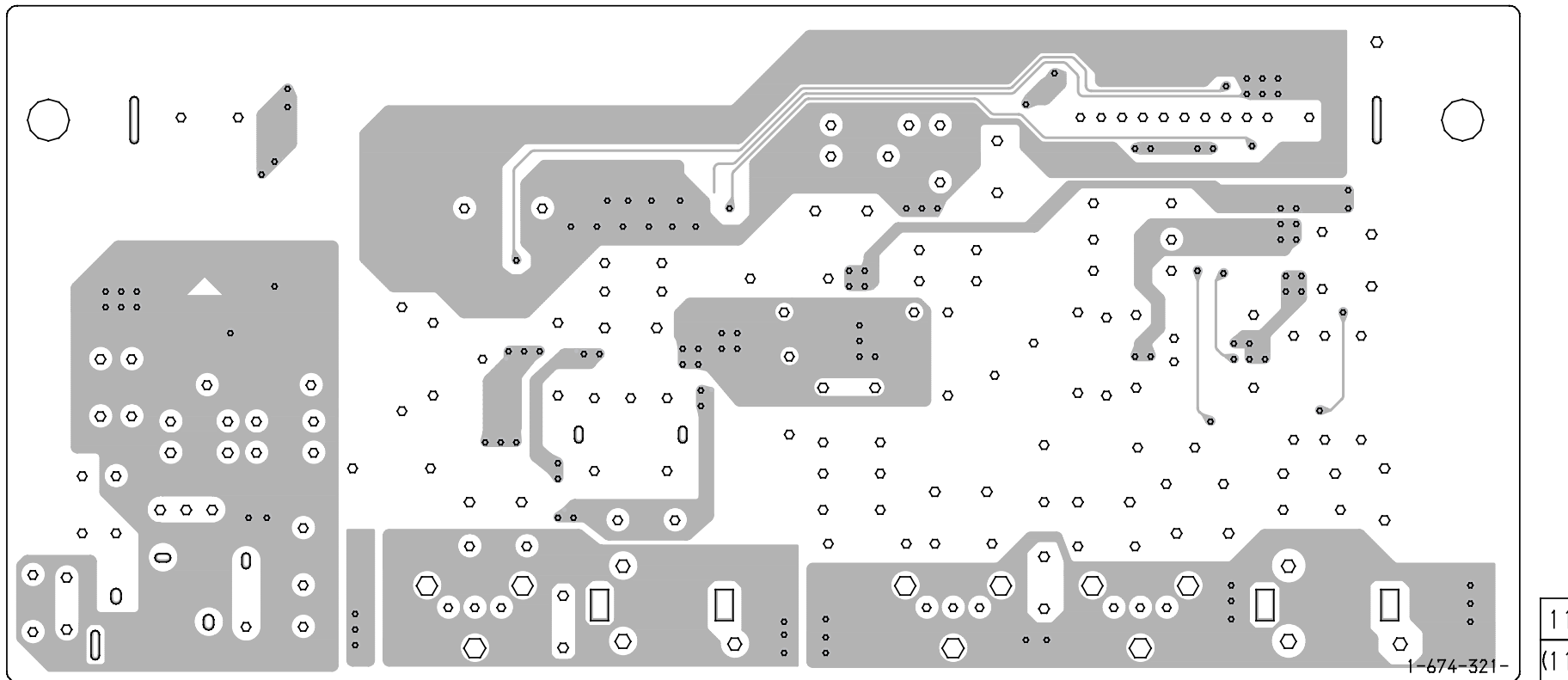

【PJ BOARD】 (COMPONENT SIDE)

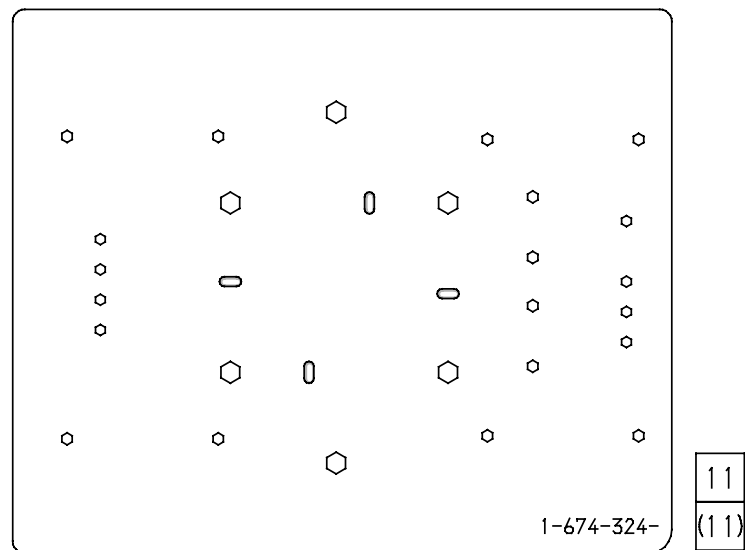

【HP BOARD】 (COMPONENT SIDE)

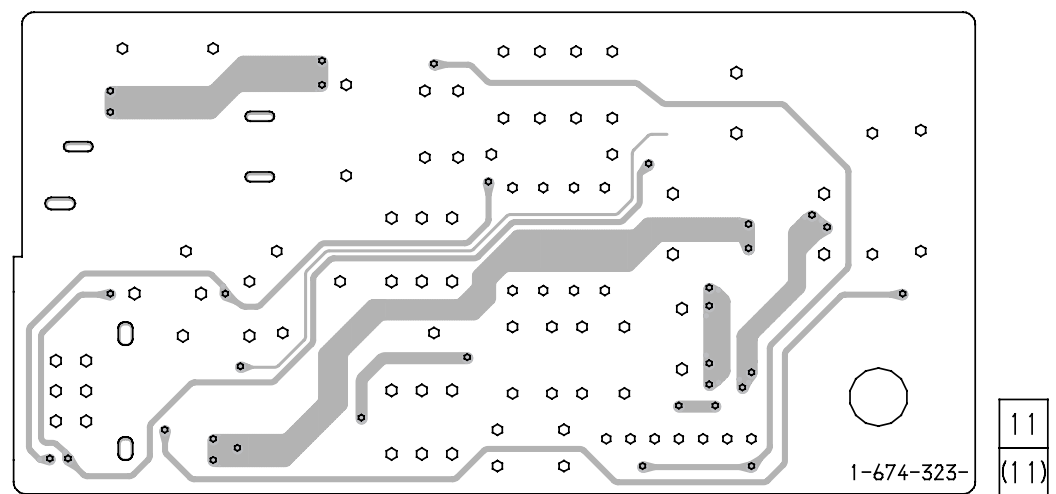



1 2 3 4 5 6 7 8 9 10 11 12

(Page 46) (Page 42)

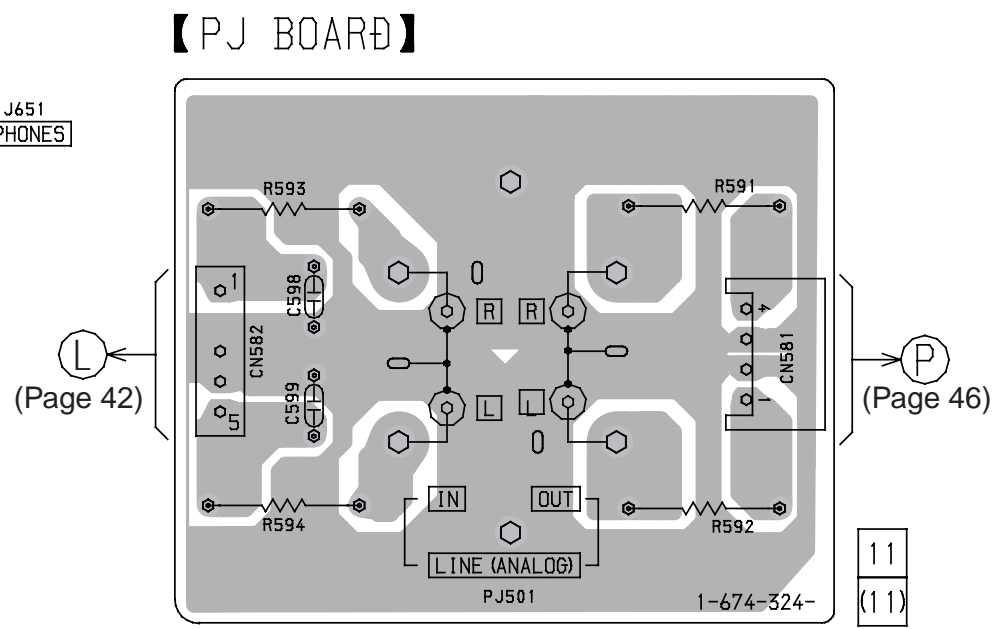
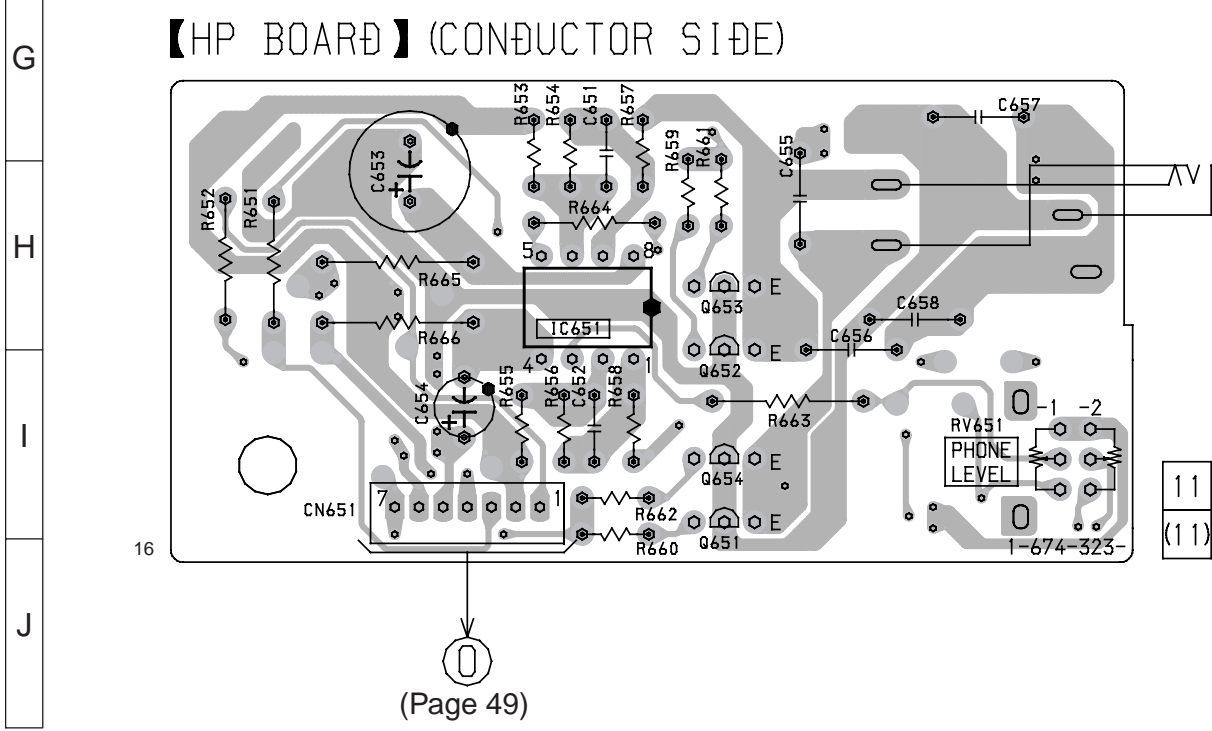
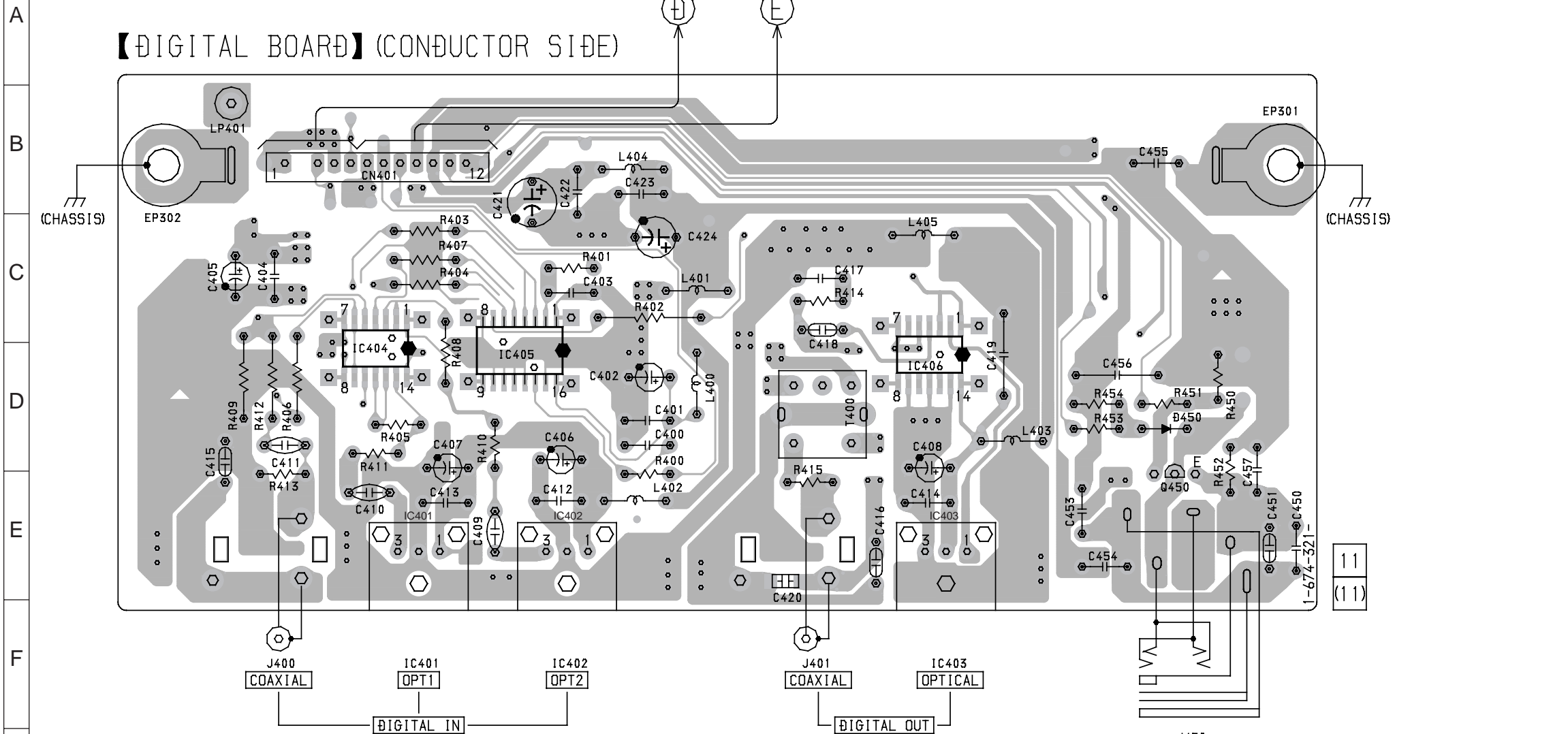

• Semiconductor Location

| Ref. No. | Location |
|----------|----------|
| D450     | D-9      |
| IC401    | E-4      |
| IC402    | E-5      |
| IC403    | E-8      |
| IC404    | D-3      |
| IC405    | D-4      |
| IC406    | D-8      |
| IC651    | H-3      |
| Q450     | E-10     |
| Q651     | J-4      |
| Q652     | I-4      |
| Q653     | H-4      |
| Q654     | I-4      |

6-15. SCHEMATIC DIAGRAM DIGITAL SECTION • Refer to page 37 for Note on Schematic Diagrams. • Refer to page 61 for IC Block Diagrams.

1 2 3 4 5 6 7 8 9 10 11 12 13

A  
B  
C  
D  
E  
F  
G  
H  
I  
J

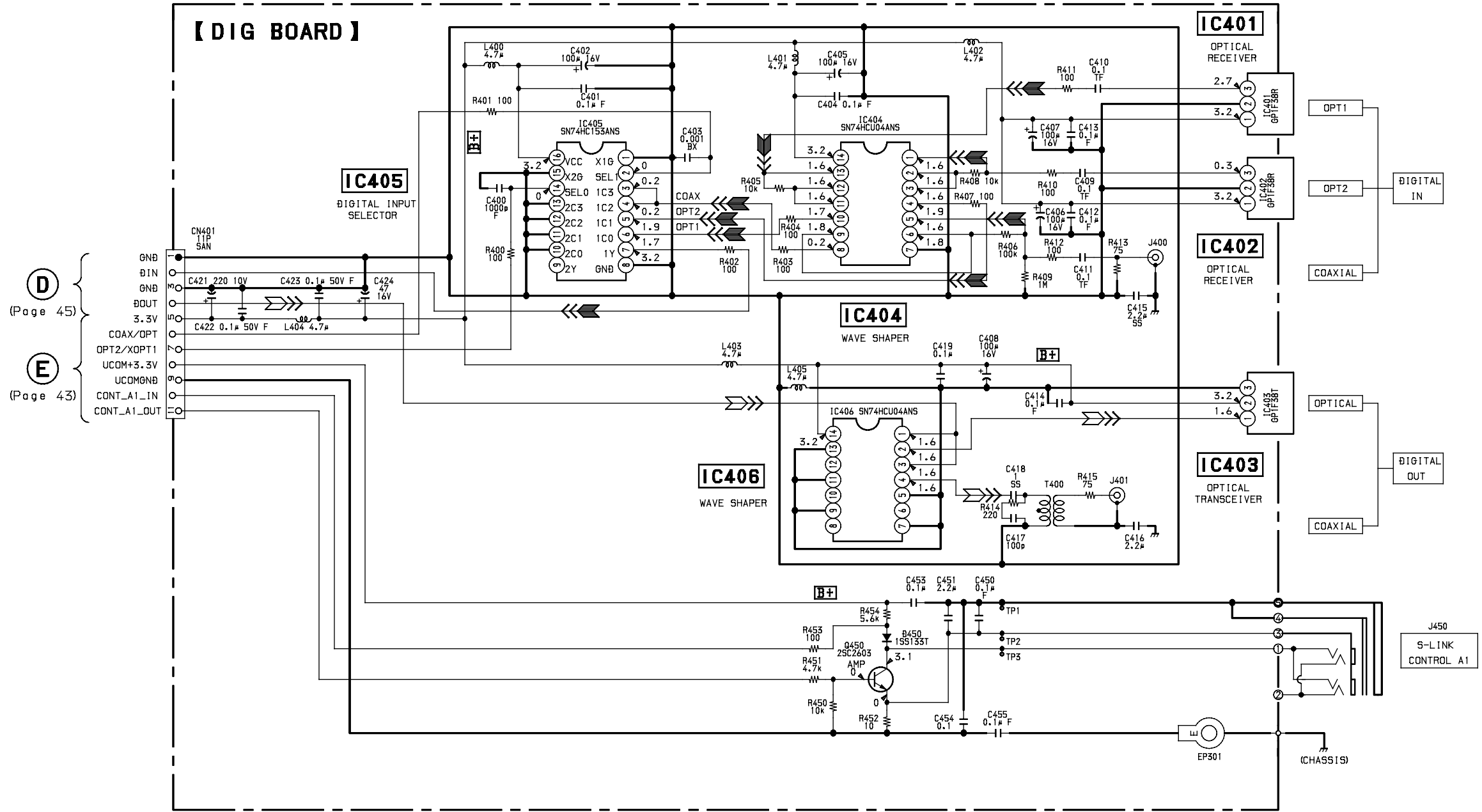

(D) (Page 45)  
GND  
BIN  
GND  
BOUT  
3.3V  
COAX/OPT  
OPT2/XOPT1  
UCOM+3.3V  
UCOMGND  
CONT\_A1\_IN  
CONT\_A1\_OUT

(O) (Page 46)  
HPL  
GND  
HPR  
-12V  
GND  
+12V  
HPMUTE

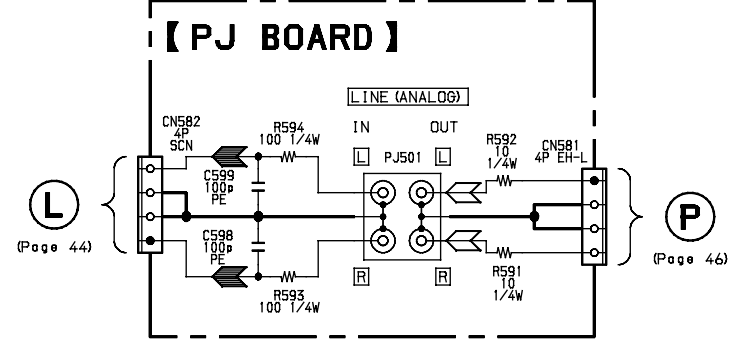
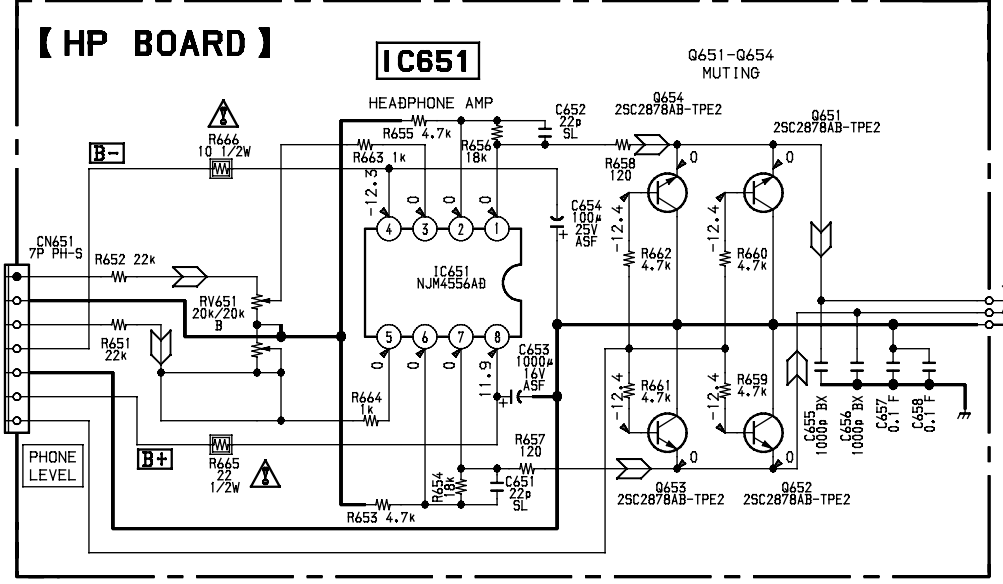

**NOTE**  
• Voltages and waveforms are dc with respect to ground under no-signal conditions.  
no mark: PLAY

The components identified by mark  $\Delta$  or dotted line with mark  $\Delta$  are critical for safety. Replace only with part number specified.  
Les composants identifiés par une marque  $\Delta$  sont critiques pour la sécurité. Ne les remplacer que par une pièce portant le numéro spécifié.

6-16. PRINTED WIRING BOARD AC SECTION • Refer to page 37 for Note on Printed Wiring Boards. • Refer to page 37 for Circuit Board Location.

【AC BOARD】(COMPONENT SIDE)

【AC BOARD】(CONDUCTOR SIDE)

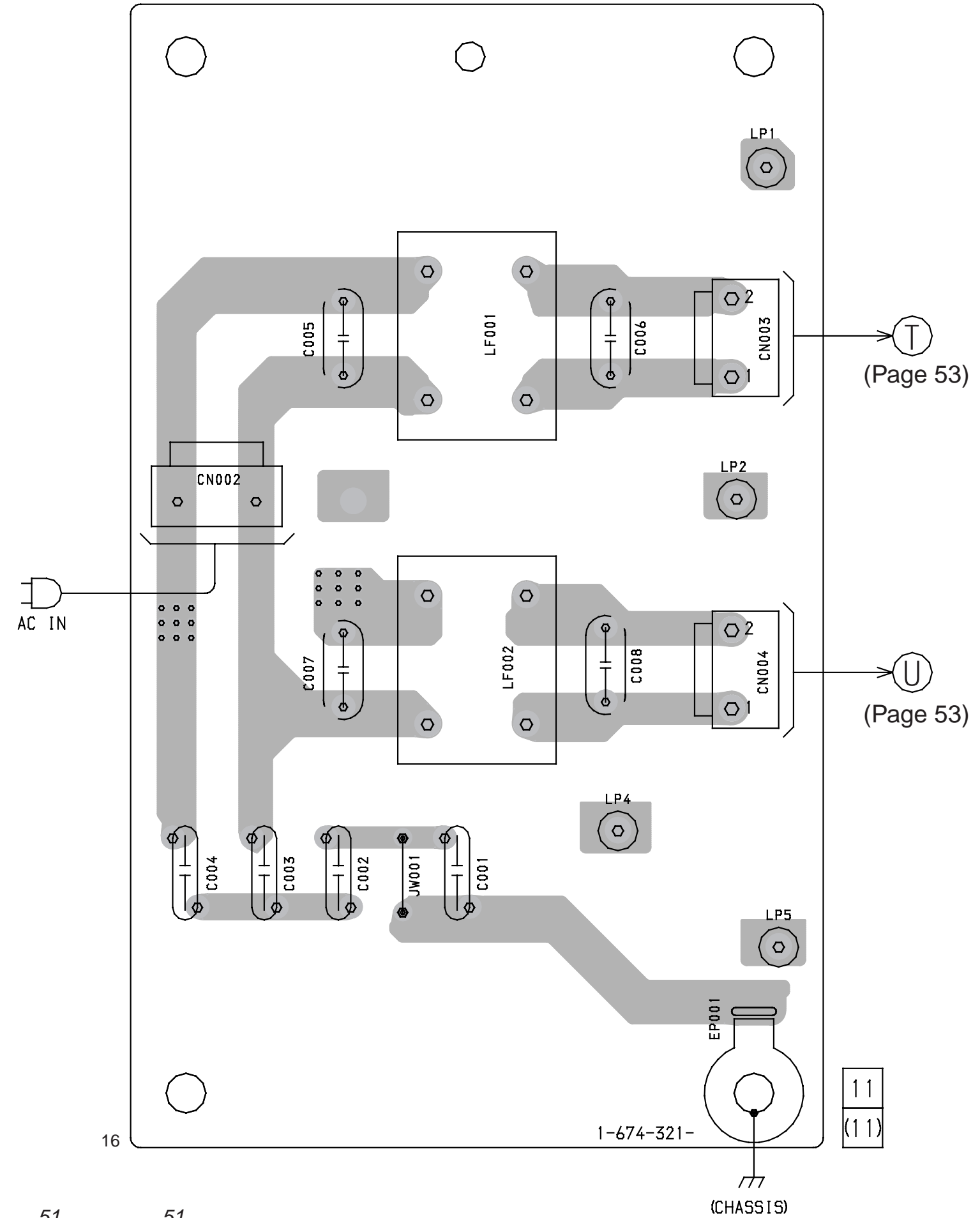
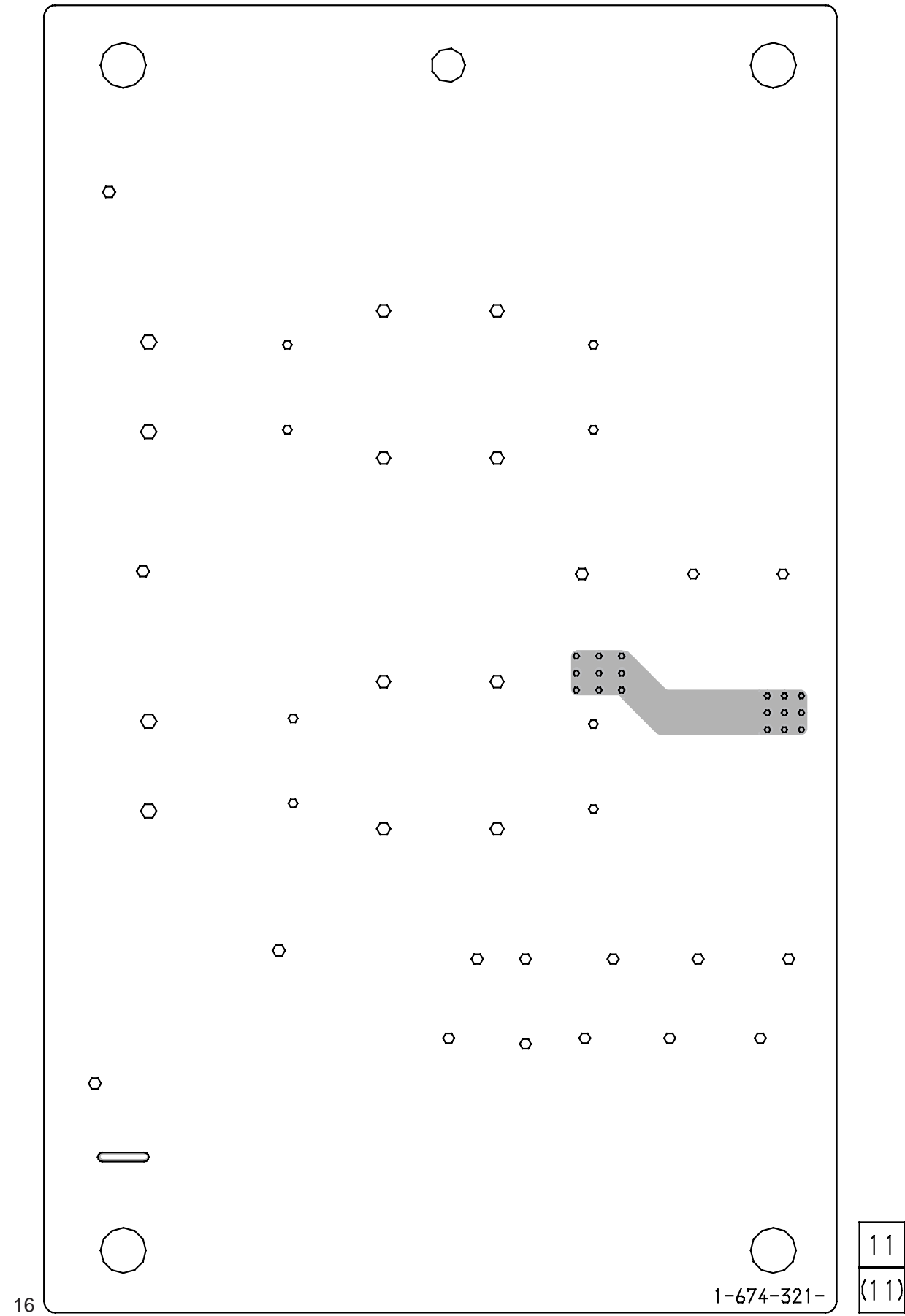

6-17. SCHEMATIC DIAGRAM POWER SECTION • Refer to page 37 for Note on Schematic Diagrams. • Refer to page 61 for Circuit Board Location.

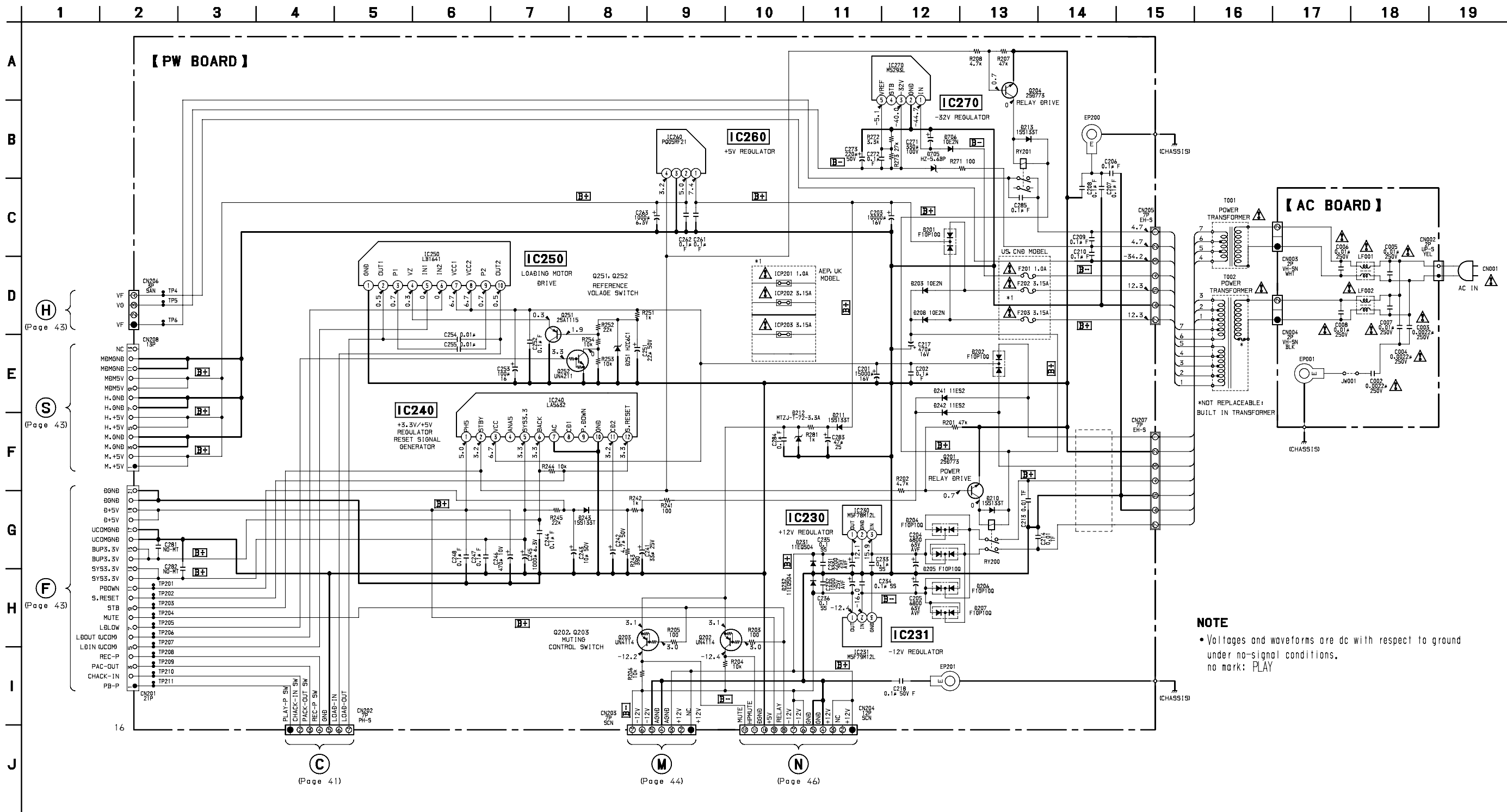

**NOTE**  
 • Voltages and waveforms are dc with respect to ground under no-signal conditions.  
 no mark: PLAY

The components identified by mark  $\Delta$  or dotted line with mark  $\Delta$  are critical for safety. Replace only with part number specified.

Les composants identifiés par une marque  $\Delta$  sont critiques pour la sécurité. Ne les remplacer que par une pièce portant le numéro spécifié.

6-18. PRINTED WIRING BOARD POWER SECTION • Refer to page 37 for Note on Printed Wiring Boards. • Refer to page 37 for Circuit Board Location.

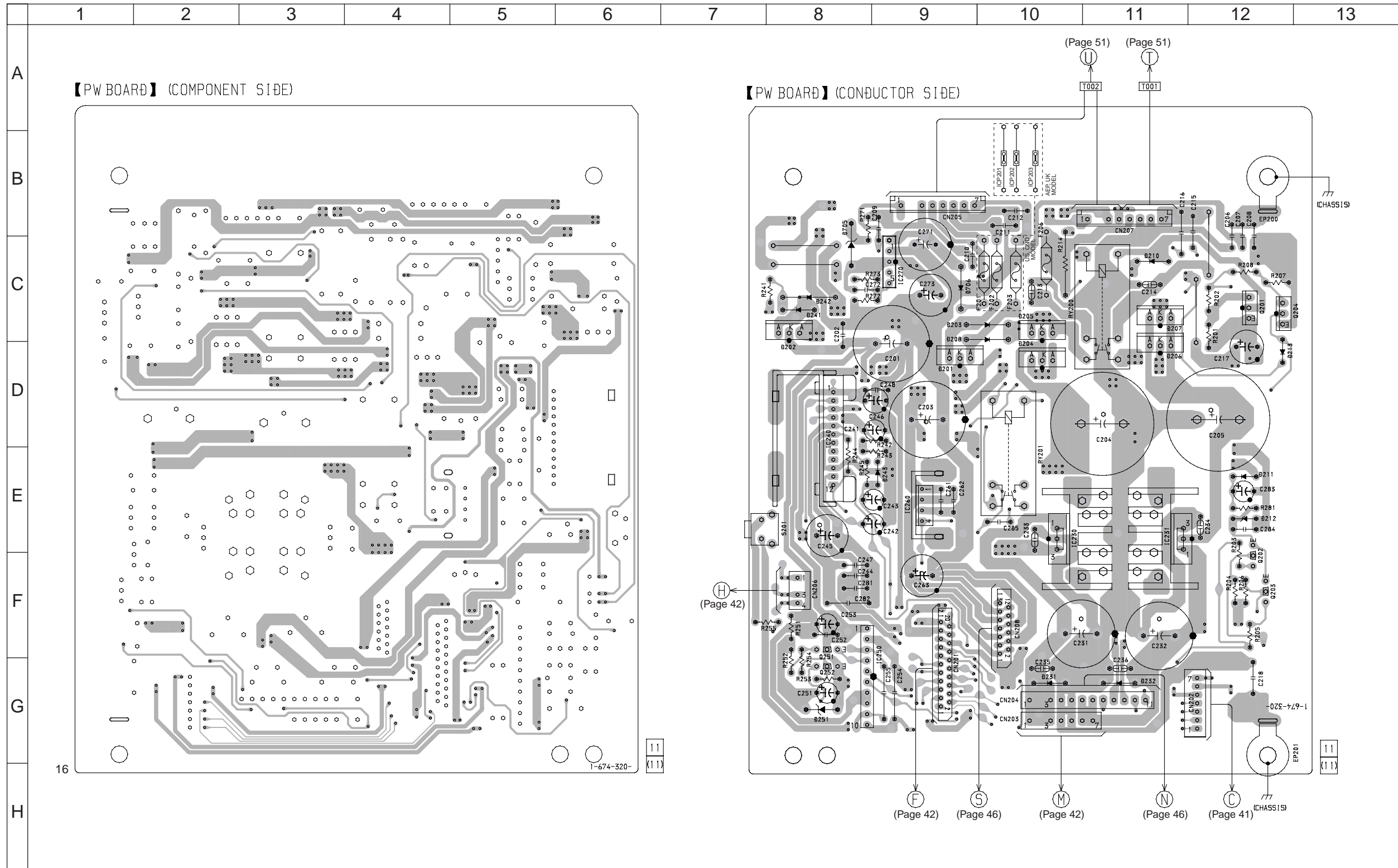

• Semiconductor Location

| Ref. No. | Location |
|----------|----------|
| D201     | D-9      |
| D202     | C-8      |
| D203     | C-9      |
| D204     | D-10     |
| D205     | C-10     |
| D206     | D-11     |
| D207     | C-11     |
| D208     | C-9      |
| D210     | C-11     |
| D211     | E-11     |
| D212     | E-12     |
| D213     | D-12     |
| D231     | G-10     |
| D232     | G-11     |
| D241     | C-8      |
| D242     | C-8      |
| D243     | E-9      |
| D251     | G-8      |
| D705     | B-8      |
| D706     | C-9      |
| IC230    | E-10     |
| IC231    | E-11     |
| IC240    | D-8      |
| IC250    | F-9      |
| IC260    | E-9      |
| IC270    | C-9      |
| Q201     | C-12     |
| Q202     | E-12     |
| Q203     | F-12     |
| Q204     | C-12     |
| Q251     | F-8      |
| Q252     | G-8      |

6-19. PRINTED WIRING BOARD PANEL SECTION • Refer to page 37 for Note on Printed Wiring Boards. • Refer to page 37 for Circuit Board Location.

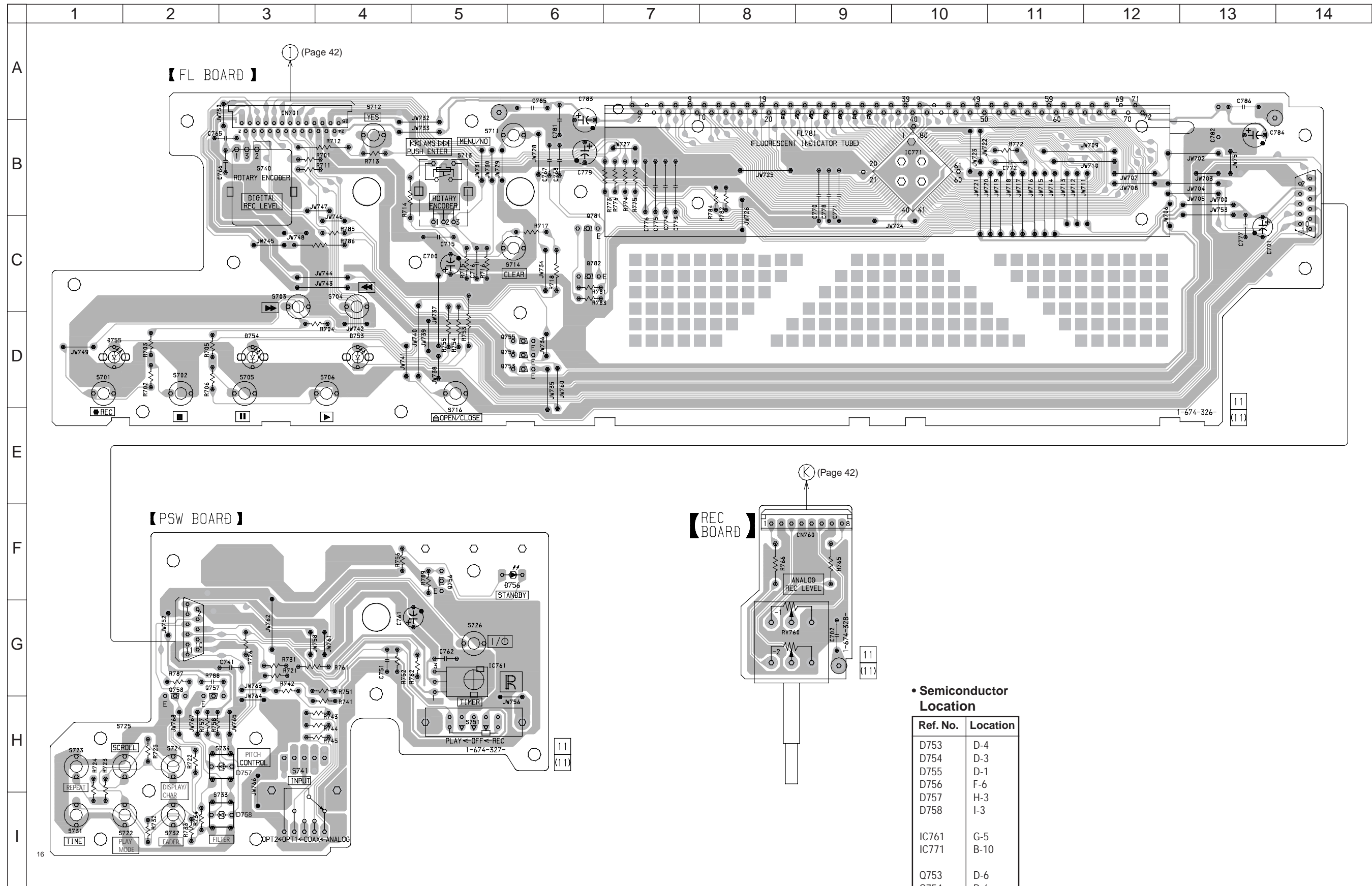

• Semiconductor Location

| Ref. No. | Location |
|----------|----------|
| D753     | D-4      |
| D754     | D-3      |
| D755     | D-1      |
| D756     | F-6      |
| D757     | H-3      |
| D758     | I-3      |
| IC761    | G-5      |
| IC771    | B-10     |
| Q753     | D-6      |
| Q754     | D-6      |
| Q755     | D-6      |
| Q756     | F-5      |
| Q757     | G-3      |
| Q758     | G-2      |
| Q781     | C-6      |
| Q782     | C-6      |

6-20. SCHEMATIC DIAGRAM PANEL SECTION • Refer to page 37 for Note on Schematic Diagrams. • Refer to page 56 for Waveforms.

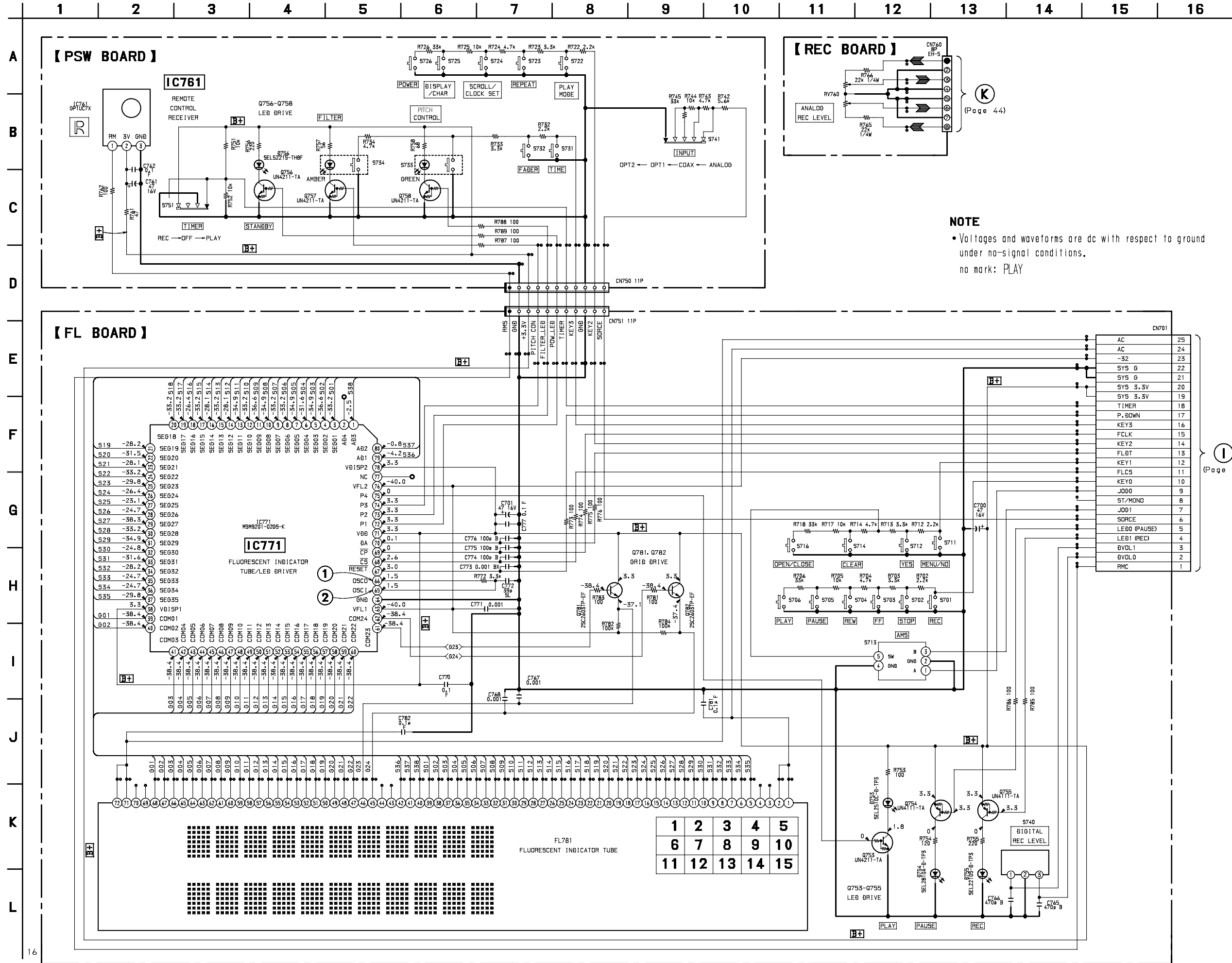

**NOTE**  
 • Voltages and waveforms are dc with respect to ground under no-signal conditions.  
 no mark: PLAY

(Page 43)

|    |    |    |    |    |
|----|----|----|----|----|
| 1  | 2  | 3  | 4  | 5  |
| 6  | 7  | 8  | 9  | 10 |
| 11 | 12 | 13 | 14 | 15 |

• Waveforms

**BD SECTION**

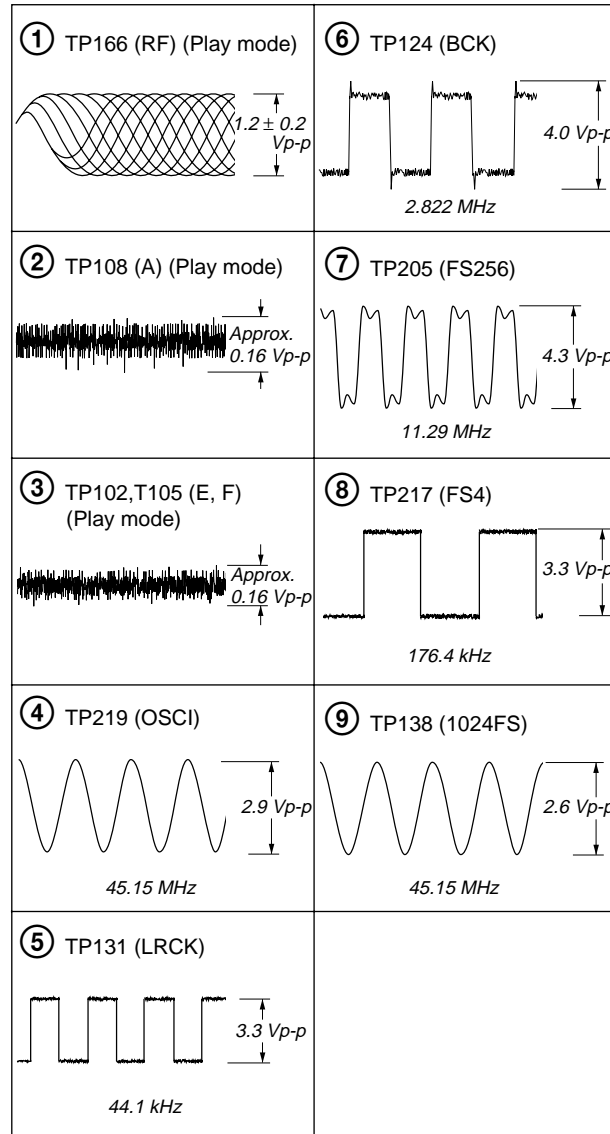

**AD SECTION**

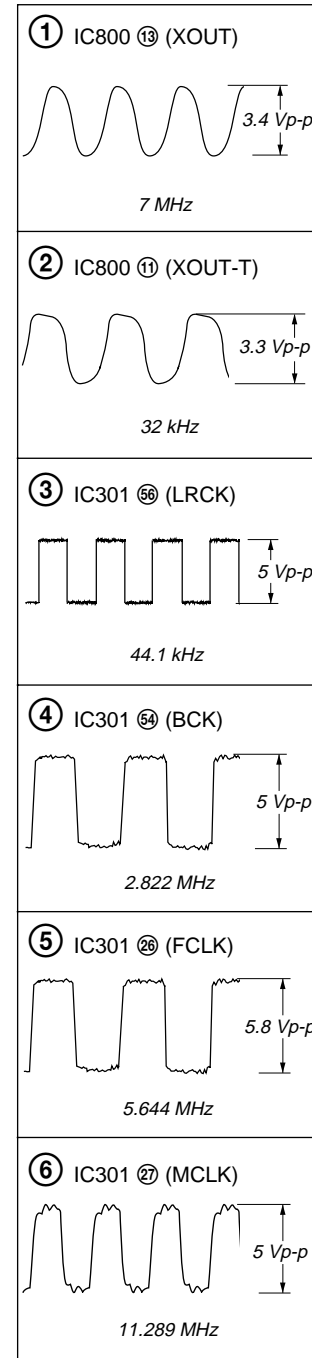

**DA SECTION**

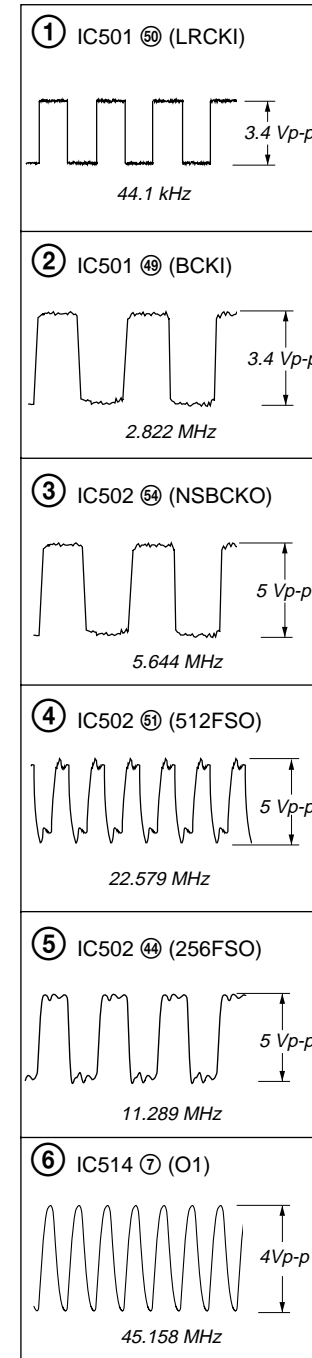

**FL SECTION**

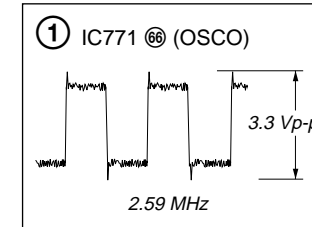



**6-21. IC BLOCK DIAGRAMS**  
**IC101 CXA2523AR (BD BOARD)**

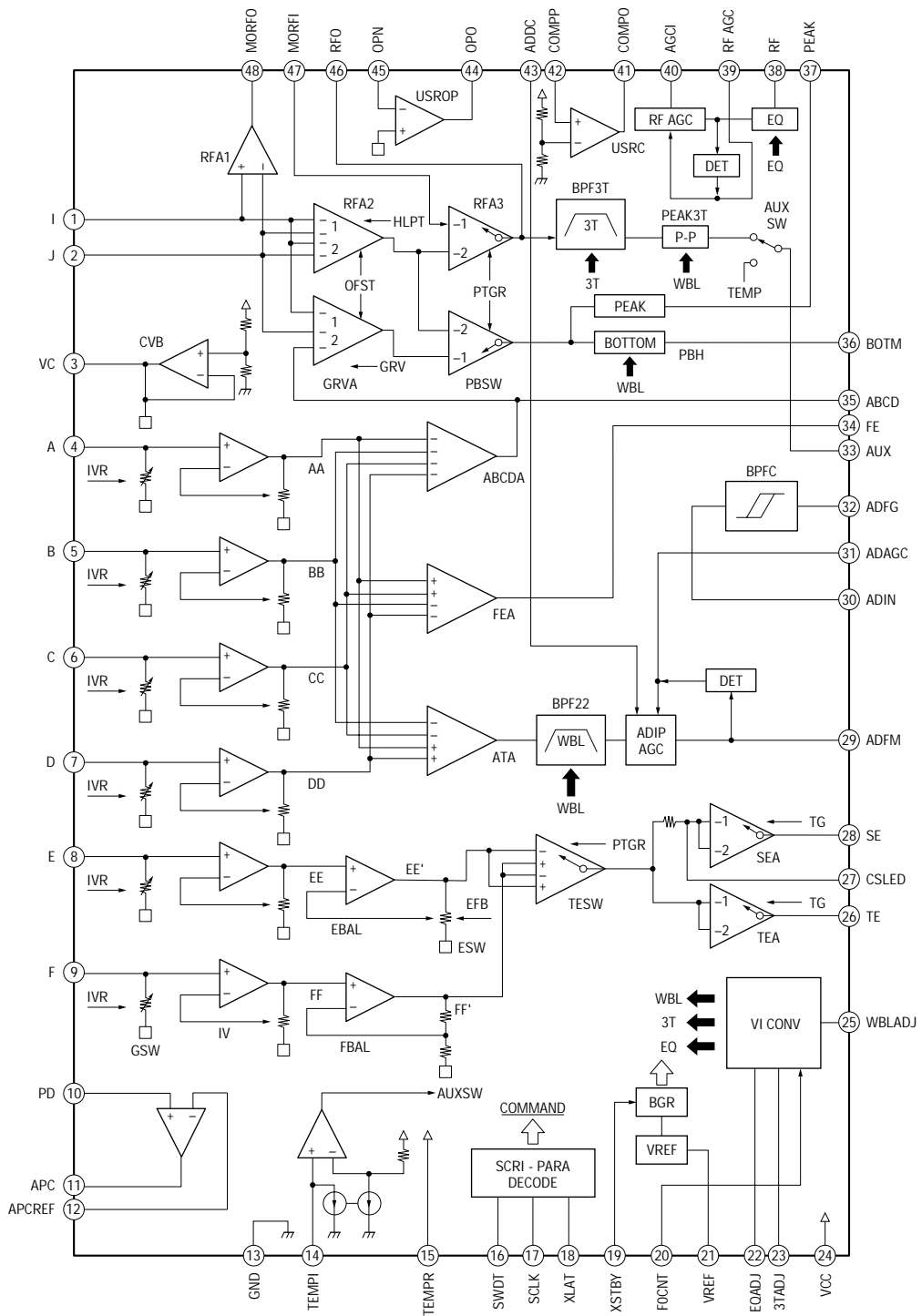

**IC121 CXD2656R (BD BOARD)**

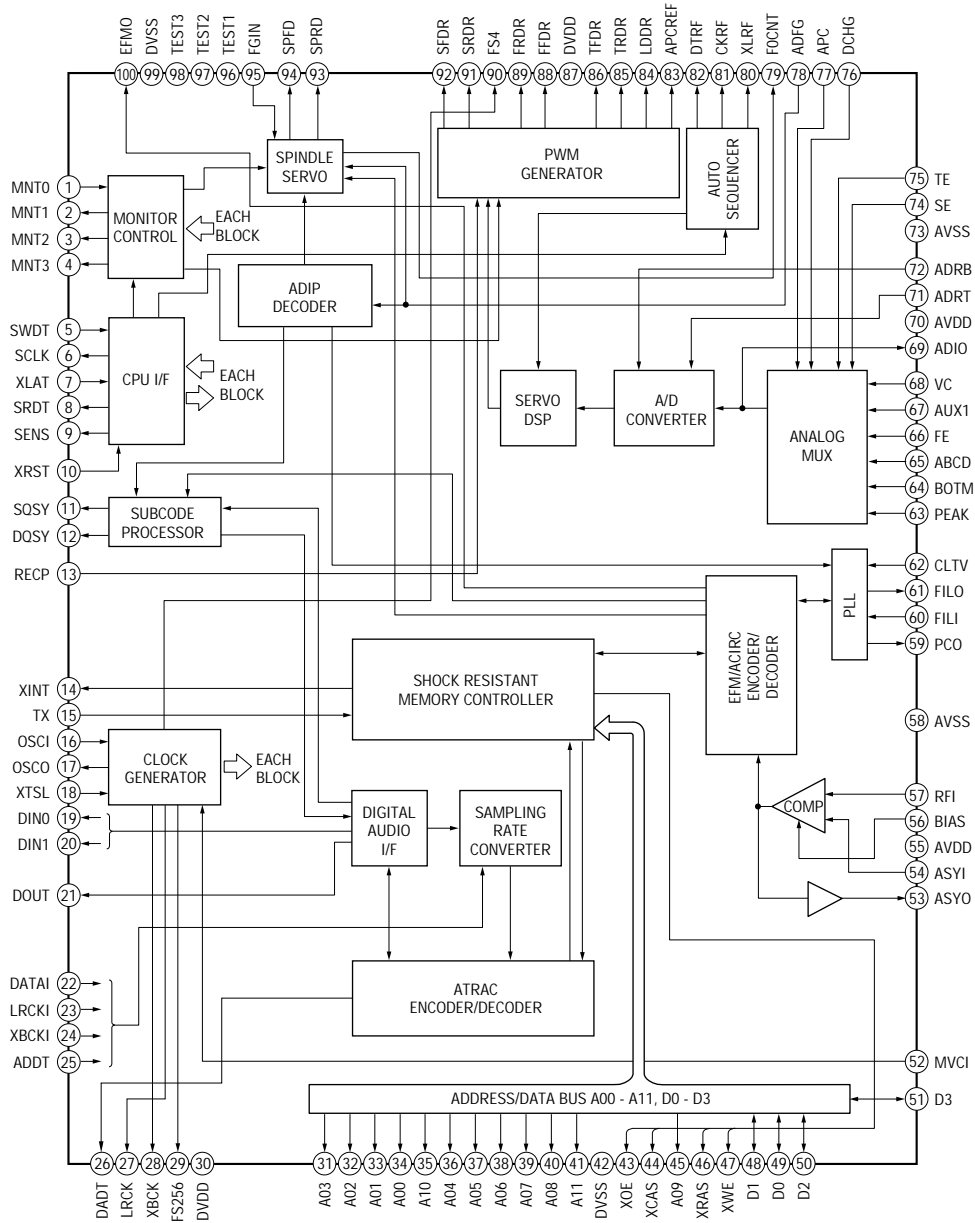

**IC152 BH6511FS (BD BOARD)**

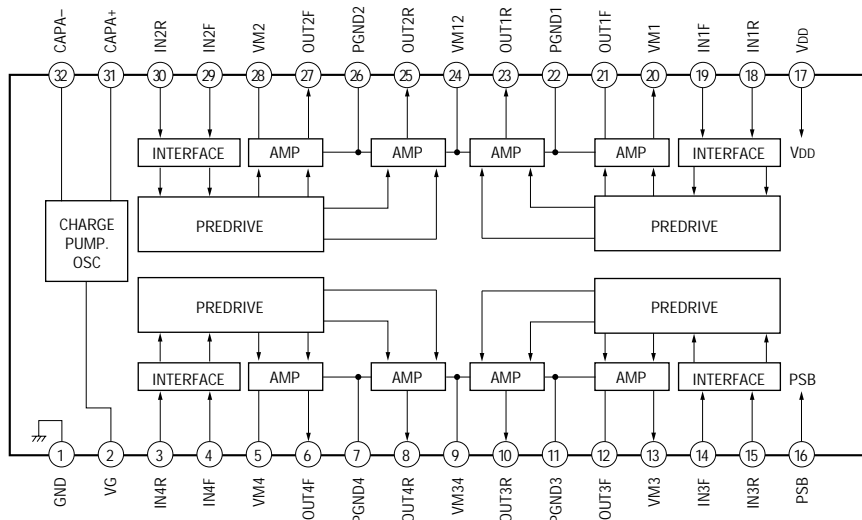

**IC302 CXD8493M-E1 (AD BOARD)**

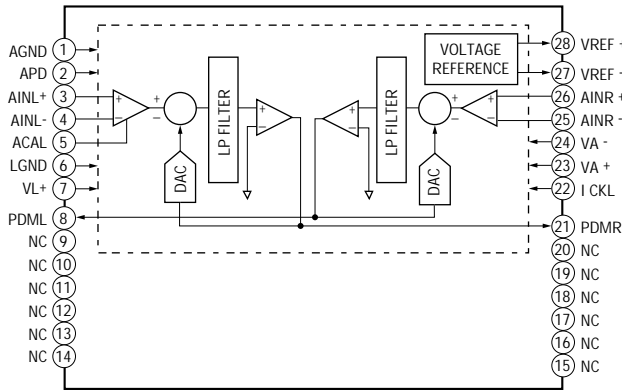

**IC803, 804 TC74VHCT244AF(EL) (AD BOARD)**

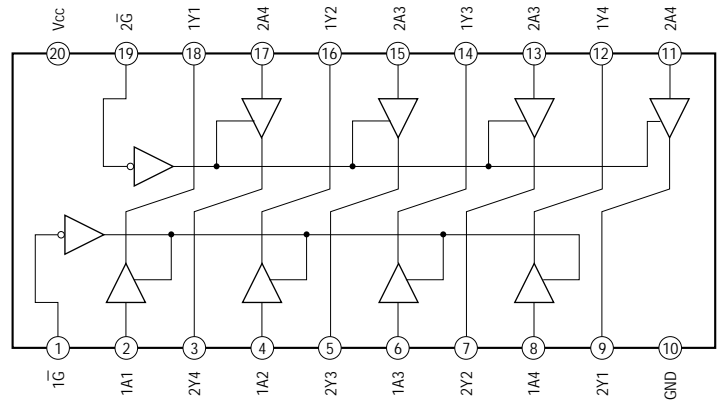

**IC501 CXD8762Q (DA BOARD)**

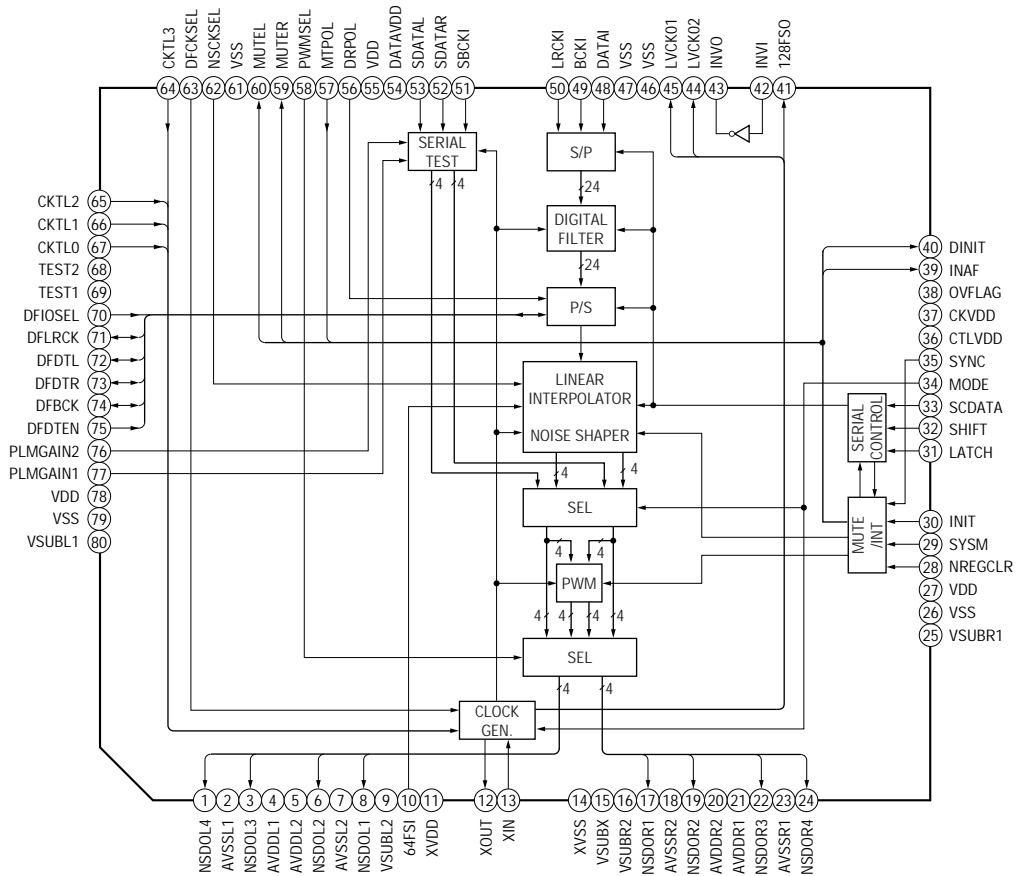

**IC502 CXD9521Q (DA BOARD)**

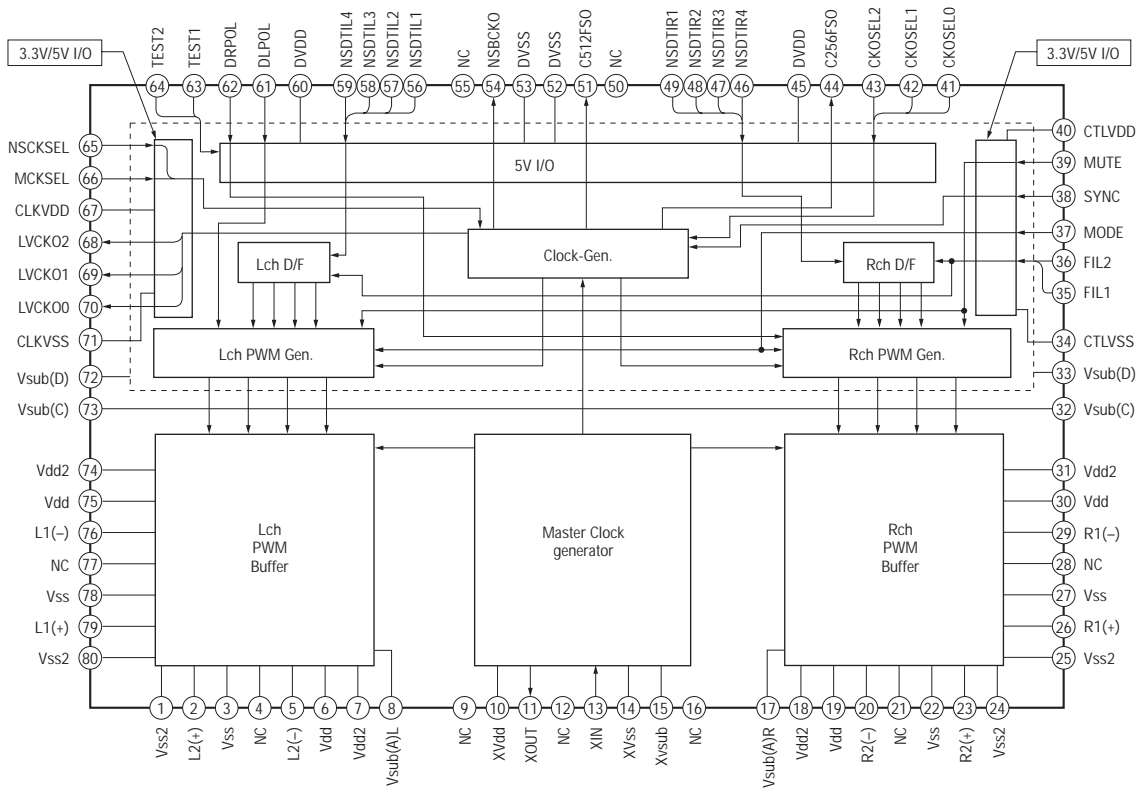

**IC504, 505 CXA8042AS (DA BOARD)**

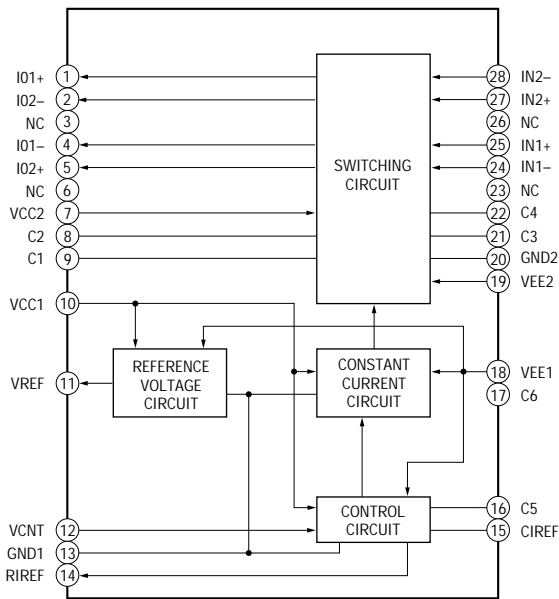

**IC405 SN74HC153ANS (DIGITAL BOARD)**

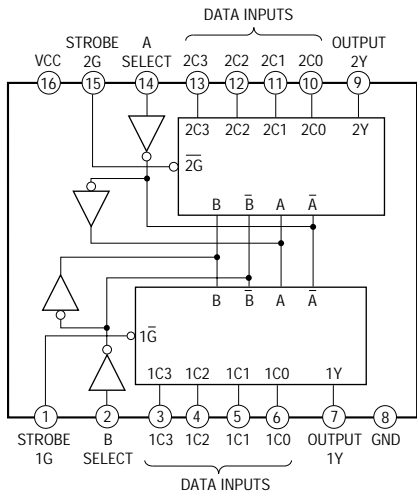

**IC240 LA5632 (PW BOARD)**

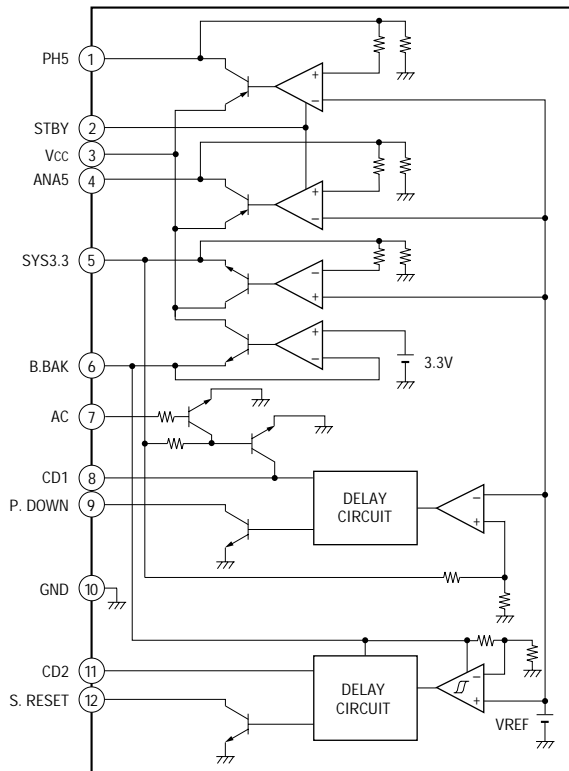

**IC250 LB1641 (PW BOARD)**

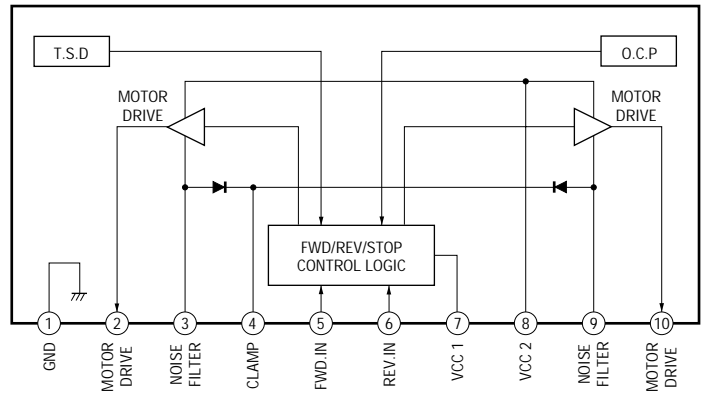

**IC270 M5293L (PW BOARD)**

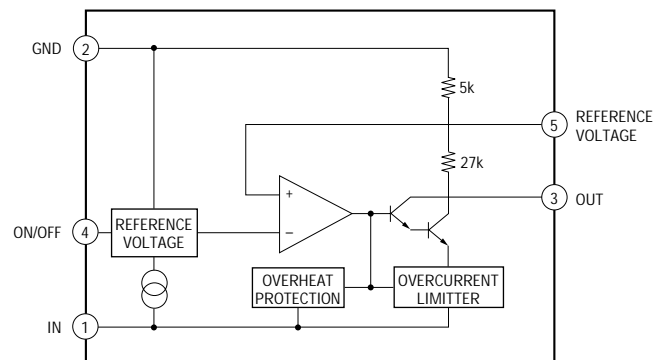

## 6-22. IC PIN FUNCTION DESCRIPTION

### • BD BOARD IC101 CXA2523AR (RF AMPLIFIER, FOCUS/TRACKING ERROR AMPLIFIER)

| Pin No. | Pin Name | I/O | Description  |
|---------|----------|-----|--|
| 1       | I        | I   | RF signal input (I) that is supplied from the optical pickup detector and has already been I-V converted                 |
| 2       | J        | I   | RF signal input (J) that is supplied from the optical pickup detector and has already been I-V converted                 |
| 3       | VC       | O   | Middle point voltage (+1.65 V) generation output   |
| 4 to 9  | A to F   | I   | Signal input from optical pick-up detector (A to F)  |
| 10      | PD       | I   | Light amount monitor input from laser diode of optical pick-up   |
| 11      | APC      | O   | Laser amplifier output to automatic power control circuit  |
| 12      | APCREF   | I   | Reference voltage input for setting laser power from CXD2656R (IC121)  |
| 13      | GND      | —   | Ground   |
| 14      | TEMPI    | I   | Temperature sensor connection pin  |
| 15      | TEMPR    | O   | Reference voltage output for temperature sensor  |
| 16      | SWDT     | I   | Write data signal input from CXD2656R (IC121)  |
| 17      | SCLK     | I   | Serial clock signal input from CXD2656R (IC121)  |
| 18      | XLAT     | I   | Serial latch signal input from CXD2656R (IC121)  |
| 19      | XSTBY    | I   | Standby signal input   |
| 20      | FOCNT    | I   | Control signal input of center frequency for internal circuit filter (BPF22, BPF3T, EQ) from CXD2656R (IC121)            |
| 21      | VREF     | O   | Reference voltage output Not used in this system (Blank terminal)  |
| 22      | EQADJ    | I   | Input pin for setting center frequency of internal circuit filter (EQ)   |
| 23      | 3TADJ    | I   | Input pin for setting center frequency of internal circuit filter (BPF3T)  |
| 24      | VCC      | —   | Power supply (+33 V)   |
| 25      | WBLADJ   | I   | Input pin for setting center frequency of internal circuit filter (BPF22)  |
| 26      | TE       | O   | Tracking error signal output to CXD2656R (IC121)   |
| 27      | CSLED    | I   | Connection pin of capacitor for low path filter of sled error  |
| 28      | SE       | O   | Sled error signal output to CXD2656R (IC121)   |
| 29      | ADFM     | O   | ADIP FM signal output  |
| 30      | ADIN     | I   | Inputs ADIP FM signal by AC coupling   |
| 31      | ADAGC    | I   | Connection pin of external capacitor for ADIP AGC  |
| 32      | ADFG     | O   | ADIP dual FM signal output to CXD2656R (IC121) (2205 kHz $\pm$ 1 kHz)  |
| 33      | AUX      | O   | Auxiliary signal (I3 signal/temperature signal) output to CXD2656R (IC121)   |
| 34      | FE       | O   | Focus error signal output to CXD2656R (IC121)  |
| 35      | ABCD     | O   | Light amount signal (ABCD) output to CXD2656R (IC121)  |
| 36      | BOTM     | O   | Bottom hold signal output of light amount signal (RF/ABCD) to CXD2656R (IC121)   |
| 37      | PEAK     | O   | Peak hold signal output of light amount signal (RF/ABCD) to CXD2656R (IC121)   |
| 38      | RF       | O   | Playback EFM RF signal output to CXD2656R (IC121)  |
| 39      | RFAGC    | I   | Connection pin of RF AGC circuit external capacitor  |
| 40      | AGCI     | I   | Inputs RF signal by AC coupling  |
| 41      | COMPO    | O   | Output terminal to user's comparator. Not used. (Blank terminal)   |
| 42      | COMPP    | I   | Inverted input terminal from user's comparator. Not used. (Fixed to "L")   |
| 43      | ADDC     | I   | The terminal to which external capacitor to cut off low frequency range of the ADIP amplifier, is going to be connected. |
| 44      | OPO      | O   | Output terminal to user's operational amplifier. Not used. (Blank terminal)  |
| 45      | OPN      | I   | Inverted input terminal from user's operational amplifier. Not used. (Fixed to "L")                                      |
| 46      | RFO      | O   | Output pin of RF signal  |
| 47      | MORFI    | I   | Inputs MO RF signal by AC coupling   |
| 48      | MORFO    | O   | Output pin of MO RF signal   |

• **BD BOARD IC121 CXD2656R (DIGITAL SIGNAL PROCESSOR, DIGITAL SERVO SIGNAL PROCESSOR, EFM/ACIR ENCODER/DECODER, SHOCK-PROOF REMOTE CONTROLLER, ATRAC ENCODER/DECODER)**

| Pin No.  | Pin Name                 | I/O   | Description   |
|----------|--------------------------|-------|---|
| 1        | MNT0 (FOK)               | O     | Focus OK signal output to system controller (IC800)<br>Outputs "H" when focus is set ("L": NG)  |
| 2        | MNT1 (SHOCK)             | O     | Track jump detection signal output to system controller (IC800)   |
| 3        | MNT2 (XBUSY)             | O     | Busy monitor signal output to system controller (IC800)   |
| 4        | MNT3                     | O     | Spindle servo lock status monitoring signal output to system controller (IC800)   |
| 5        | SWDT                     | I     | Inputs write data signal from system controller (IC800)   |
| 6        | SCLK                     | I (S) | Inputs serial clock signal from system controller (IC800)   |
| 7        | XLAT                     | I (S) | Inputs serial latch signal from system controller (IC800)   |
| 8        | SRDT                     | O (3) | Outputs read data signal to system controller (IC800)   |
| 9        | SENS                     | O (3) | Outputs internal status (SENSE) signal to system controller (IC800)   |
| 10       | $\overline{\text{XRST}}$ | I (S) | Inputs reset signal input from system controller (IC800) "L": Reset   |
| 11       | SQSY                     | O     | Sub code Q sync (SCOR) output to system controller (IC800)<br>Outputs "L" every 133 msec. Outputs "H" mostly  |
| 12       | DQSY                     | O     | Outputs digital-in U-bit CD format sub code Q sync (SCOR) to system controller (IC800)<br>Outputs "L" every 133 msec. Outputs "H" mostly                              |
| 13       | RECP                     | I     | Laser power switching signal input from system controller (IC800)<br>"L": Playback, "H": Recording  |
| 14       | XINT                     | O     | Interrupt status output to system controller (IC800)  |
| 15       | TX                       | I     | Recording data output enable signal input from system controller (IC800).<br>Transmission timing of the write signal is input. (Used also as ON/OFF of magnetic head) |
| 16       | OSCI                     | I     | System clock (1024Fs = 451584 MHz) input  |
| 17       | OSCO                     | O     | System clock (1024Fs = 451584 MHz) output. Not used in this system (Blank terminal)   |
| 18       | XTSL                     | I     | System clock frequency setting input.<br>"L": 451584 MHz, "H": 22.5792 kHz  |
| 19       | DIN0                     | I     | Recording system digital audio signal input (for digital optical -1/2 input and coaxial input)  |
| 20       | DIN1                     | I     | Recording system digital audio signal input. Not used (Fix at "L")  |
| 21       | DOUT                     | O     | Playback system digital audio signal output (for digital optical output and coaxial input)  |
| 22       | DATAI                    | I     | Serial data input Not used (Fix at "L")   |
| 23       | LRCKI                    | I     | L/R sampling clock signal input (44.1 kHz)<br>Not used in this system (Fixed at "L")  |
| 24       | XBCKI                    | I     | Bit clock signal input of serial input/output (2.8224 kHz)<br>Not used in this system (Fixed at "L")  |
| 25       | ADDT                     | I     | Recording data signal input from CXD8512Q (IC301)   |
| 26       | DADT                     | O     | Playback data signal output from CXD8512Q (IC301)   |
| 27       | LRCK                     | O     | L/R sampling clock signal output (44.1 kHz) to CXD8512Q (IC301) and CXD8762Q (IC501)  |
| 28       | XBCK                     | O     | Bit clock signal output of serial input/output data (44.1 kHz) to CXD8512Q (IC301) and CXD8762Q (IC501)   |
| 29       | FS256                    | O     | 11.2896 MHz clock signal output Not used (Blank terminal)   |
| 30       | DVDD                     | —     | Power supply (+5 V) (Digital)   |
| 31 to 34 | A03 to A00               | O     | Address signal output to D-RAM (IC124)  |
| 35       | A10                      | O     | Address signal output to external D-RAM Not used (Blank terminal)   |
| 36 to 40 | A04 to A08               | O     | Address signal output to D-RAM (IC124)  |

\* I (S) of I/O is schmitt input, I (A) is analog input, O (3) is 3-state output, O (A) is analog output

| Pin No. | Pin Name                 | I/O   | Description  |
|---------|--------------------------|-------|--|
| 41      | A11                      | O     | Address signal output to external D-RAM Not used (Blank terminal)  |
| 42      | DVSS                     | —     | Ground (Digital)   |
| 43      | $\overline{\text{XOE}}$  | O     | Output enable signal output to D-RAM (IC124) "L": Active   |
| 44      | $\overline{\text{XCAS}}$ | O     | Column address strobe signal output to D-RAM (IC124) "L": Active   |
| 45      | A09                      | O     | Address signal output to D-RAM (IC124)   |
| 46      | $\overline{\text{XRAS}}$ | O     | Low address strobe signal output to D-RAM (IC124) "L": Active  |
| 47      | $\overline{\text{XWE}}$  | O     | Write enable signal output to D-RAM (IC124) "L": Active  |
| 48      | D1                       | I/O   | Bi-directional data bus with D-RAM (IC124)   |
| 49      | D0                       | I/O   |  |
| 50      | D2                       | I/O   |  |
| 51      | D3                       | I/O   |  |
| 52      | MVCI                     | I (S) | Input to digital-in PLL oscillation from external VCO. Not used (Fix at "L")   |
| 53      | ASYO                     | O     | Playback EFM full-swing output   |
| 54      | ASYI                     | I (A) | Playback EFM asymmetry compare voltage input   |
| 55      | AVDD                     | —     | Power supply (+3.3 V) (Analog)   |
| 56      | BIAS                     | I (A) | Constant current input to playback EFM asymmetry circuit   |
| 57      | RFI                      | I (A) | Playback EFM RF signal input from CXA2523AR (IC101)  |
| 58      | AVSS                     | —     | Ground (+3.3 V) (Analog)   |
| 59      | PCO                      | O (3) | Phase comparator output to master clock of the master PLL of the record/playback EFM system                          |
| 60      | FILI                     | I (A) | Filter input to master clock of the master PLL of the record/playback EFM system                                     |
| 61      | FILO                     | O (A) | Filter output to master clock of the master PLL of the record/playback EFM system                                    |
| 62      | CLTV                     | I (A) | Internal VCO control voltage input to the master PLL of the record/playback EFM system                               |
| 63      | PEAK                     | I (A) | Peak hold signal input of light amount signal (RF/ABCD) from CXD2523AR (IC101)                                       |
| 64      | BOTM                     | I (A) | Bottom hold signal input of light amount signal (RF/ABCD) from CXD2523AR (IC101)                                     |
| 65      | ABCD                     | I (A) | Light amount signal (ABCD) from CXD2523AR (IC101)  |
| 66      | FE                       | I (A) | Focus error signal input from CXD2523AR (IC101)  |
| 67      | AUX1                     | I (A) | Auxiliary signal (I3 signal/temperature signal) output from CXD2523AR (IC101)  |
| 68      | VC                       | I (A) | Middle point voltage (+1.65 V) output from CXD2523AR (IC101)   |
| 69      | ADIO                     | O (A) | Monitor output of A/D converter input signal. Not used in this system (Blank terminal)                               |
| 70      | AVDD                     | —     | Power supply (+3.3 V) (Analog)   |
| 71      | ADRT                     | I (A) | A/D converter operation range upper limit voltage input. (Fixed to "H")  |
| 72      | ADRB                     | I (A) | A/D converter operation range lower limit voltage input. (Fixed to "L")  |
| 73      | AVSS                     | —     | Ground (Analog)  |
| 74      | SE                       | I (A) | Sled error signal input from CXD2523AR (IC101)   |
| 75      | TE                       | I (A) | Tracking error signal input from CXD2523AR (IC101)   |
| 76      | DCHG                     | I (A) | Connected to power line (+3.3 V)   |
| 77      | APC                      | I (A) | Error signal input to laser automatic power control. Not used in this system (Fixed to "H")                          |
| 78      | ADFG                     | I (S) | ADIP dual FM signal input from CXD2523AR (IC101) (22.05 kHz $\pm$ 1 kHz)   |
| 79      | F0CNT                    | O     | Filter f0 control signal output to CXD2523AR (IC101)   |
| 80      | XLRF                     | O     | Serial latch signal output to CXD2523AR (IC101)  |
| 81      | CKRF                     | O     | Serial clock signal output to CXD2523AR (IC101)  |
| 82      | DTRF                     | O     | Write data signal output to CXD2523AR (IC101)  |
| 83      | APCREF                   | O     | Control signal output for reference voltage generation circuit of laser automatic power control to CXD2523AR (IC101) |
| 84      | LDDR                     | O     | PWM signal output for laser automatic power control<br>Not used in this system (Blank terminal)                      |
| 85      | TRDR                     | O     | Tracking servo drive PWM signal output to BH6511FS (IC152) (-)   |

\* I (S) of I/O is schmitt input, I (A) is analog input, O (3) is 3-state output, O (A) is analog output



| Pin No. | Pin Name | I/O   | Description   |
|---------|----------|-------|---|
| 86      | TFDR     | O     | Tracking servo drive PWM signal output to BH6511FS (IC152)                            |
| 87      | DVDD     | —     | Power supply (+3.3 V) (Digital)   |
| 88      | FFDR     | O     | Focus servo drive PWM signal output to BH6511FS (IC152) (+)                           |
| 89      | FRDR     | O     | Focus servo drive PWM signal output to BH6511FS (IC152) (-)                           |
| 90      | FS4      | O     | 176.4 kHz clock signal output (X'tal system) Not used in this system (Blank terminal) |
| 91      | SRDR     | O     | Sled servo drive PWM signal output to BH6511FS (IC152) (-)                            |
| 92      | SFDR     | O     | Sled servo drive PWM signal output to BH6511FS (IC152) (+)                            |
| 93      | SPRD     | O     | Spindle servo drive PWM signal output to BH6511FS (IC152) (-)                         |
| 94      | SPFD     | O     | Spindle servo drive PWM signal output to BH6511FS (IC152) (+)                         |
| 95      | FGIN     | I (S) | Input pin for test (Fixed at "L")   |
| 96      | TEST1    | I     | Input pin for test (Fixed at "L")   |
| 97      | TEST2    | I     | Input pin for test (Fixed at "L")   |
| 98      | TEST3    | I     | Input pin for test (Fixed at "L")   |
| 99      | DVSS     | —     | Ground (Digital)  |
| 100     | EFMO     | O     | EFM signal output for recording to overwrite head driver (IC181)                      |

\* I (S) of I/O is schmitt input, I (A) is analog input, O (3) is 3-state output, O (A) is analog output

• AD BOARD IC301 CXD8512Q (DIGITAL FILTER)

| Pin No.       | Pin Name    | I/O  | Description   |               |     |     |     |     |    |     |     |      |
|---------------|-------------|------|---|---------------|-----|-----|-----|-----|----|-----|-----|------|
| 1             | TEST        | I    | Input pin for test (Fixed at "L")   |               |     |     |     |     |    |     |     |      |
| 2             | NC          | —    | Not used in this system (Blank terminal)  |               |     |     |     |     |    |     |     |      |
| 3             | SYNC        | I    | Sync mode selector input. "L": Slave mode. "H": Master mode. Fixed to "L"   |               |     |     |     |     |    |     |     |      |
| 4             | INIT        | I    | Reset signal input from the system controller (IC800) "L": Reset  |               |     |     |     |     |    |     |     |      |
| 5             | NC          | —    | Not used in this system (Blank terminal)  |               |     |     |     |     |    |     |     |      |
| 6             | CLFG        | O    | Flag output terminal for calibration. Not used in this system (Blank terminal)  |               |     |     |     |     |    |     |     |      |
| 7, 8          | VDD         | —    | Power supply (+5 V)   |               |     |     |     |     |    |     |     |      |
| 9             | LRKI        | I    | L/R sampling clock signal input Not used (Fixed at "L")   |               |     |     |     |     |    |     |     |      |
| 10            | BKI         | I    | Bit clock signal input of serial input/output data. Not used in this system (Fixed at "L")  |               |     |     |     |     |    |     |     |      |
| 11            | NC          | —    | Not used in this system (Blank terminal)  |               |     |     |     |     |    |     |     |      |
| 12            | DLI         | I    | L channel data input (when 8Fs, 2Fs, and FS) Not used in this system (Fixed at "L")   |               |     |     |     |     |    |     |     |      |
| 13            | DRI         | I    | R channel data input (8FS and 2FS) FSYNC input when FS Not used in this system (Fixed at "L")   |               |     |     |     |     |    |     |     |      |
| 14            | IFLG        | O    | Sync flag output terminal to the input side. Not used in this system (Blank terminal)   |               |     |     |     |     |    |     |     |      |
| 15, 16        | NC          | —    | Not used in this system (Blank terminal)  |               |     |     |     |     |    |     |     |      |
| 17            | LR          | I    | FE selection IBIT (Ⓢ-pin) "L" LR selection when "H"<br>Fixed at "L" in this system  |               |     |     |     |     |    |     |     |      |
| 18            | AL2         | I    | 64FS data (L channel data) input Not used in this system (Fixed at "L")   |               |     |     |     |     |    |     |     |      |
| 19            | AR2         | I    | 64FS data (R channel data) input Not used in this system (Fixed at "L")   |               |     |     |     |     |    |     |     |      |
| 20            | AL1         | I    | 64FS data input from A/D converter (IC302) (L channel data)   |               |     |     |     |     |    |     |     |      |
| 21            | AR1         | I    | 64FS data input from A/D converter (IC302) (R channel data)   |               |     |     |     |     |    |     |     |      |
| 22, 23        | VSS         | —    | Ground  |               |     |     |     |     |    |     |     |      |
| 24, 25        | VSS         | —    | Ground (For oscillator circuit)   |               |     |     |     |     |    |     |     |      |
| 26            | FCLK        | O    | FE clock signal output to A/D converter (IC302) (128FS)   |               |     |     |     |     |    |     |     |      |
| 27            | MCLK        | I    | Master clock signal input to D/A converter (IC502) (256FS)  |               |     |     |     |     |    |     |     |      |
| 28            | VDD         | —    | Power supply (+5 V) (For oscillator circuit)  |               |     |     |     |     |    |     |     |      |
| 29            | NC          | —    | Not used in this system (Blank terminal)  |               |     |     |     |     |    |     |     |      |
| 30            | IBIT        | I    | Input terminal to set the input data word length during 64 FS. "L": 1 bit, "H": 4 bits. (Fixed at "L")  |               |     |     |     |     |    |     |     |      |
| 31            | NC          | —    | Not used in this system (Blank terminal)  |               |     |     |     |     |    |     |     |      |
| 32            | VSS         | —    | Ground  |               |     |     |     |     |    |     |     |      |
| 33            | SCALE       | I    | Input terminal to set the scaling amount during 64 FS. "L": x5, "H": x4. (Fixed at "L")   |               |     |     |     |     |    |     |     |      |
| 34, 35        | ISET1,ISET2 | I    | Input terminal to set the input sampling frequency. (Fixed both terminals to "L" = 64 FS)<br><table border="1" style="margin-left: 20px;"> <tr> <td style="text-align: center;">ISET1 \ ISET2</td> <td style="text-align: center;">"H"</td> <td style="text-align: center;">"L"</td> </tr> <tr> <td style="text-align: center;">"H"</td> <td style="text-align: center;">8FS</td> <td style="text-align: center;">FS</td> </tr> <tr> <td style="text-align: center;">"L"</td> <td style="text-align: center;">2FS</td> <td style="text-align: center;">64FS</td> </tr> </table> | ISET1 \ ISET2 | "H" | "L" | "H" | 8FS | FS | "L" | 2FS | 64FS |
| ISET1 \ ISET2 | "H"         | "L"  |   |               |     |     |     |     |    |     |     |      |
| "H"           | 8FS         | FS   |   |               |     |     |     |     |    |     |     |      |
| "L"           | 2FS         | 64FS |   |               |     |     |     |     |    |     |     |      |
| 36            | NC          | —    | Not used in this system (Blank terminal)  |               |     |     |     |     |    |     |     |      |
| 37            | DITH        | I    | Input terminal to set the dither mode. "L": OFF, "H": ON. (Fixed at "H")  |               |     |     |     |     |    |     |     |      |
| 38            | BOOST       | I    | Input terminal to set the frequency compensation function. "L": OFF, "H": ON. (Fixed at "H")  |               |     |     |     |     |    |     |     |      |
| 39            | VDD         | —    | Power supply terminal (+5V)   |               |     |     |     |     |    |     |     |      |
| 40            | MODE        | I    | Mode data input Not used in this system (Fixed at "H")  |               |     |     |     |     |    |     |     |      |
| 41            | SHIFT       | I    | Serial data shift clock signal input Not used in this system (Fixed at "H")   |               |     |     |     |     |    |     |     |      |
| 42            | LATCH       | I    | Serial data shift latch pulse input Not used in this system (Fixed at "H")  |               |     |     |     |     |    |     |     |      |

| Pin No. | Pin Name | I/O | Description   |
|---------|----------|-----|---|
| 43      | NC       | —   | Not used in this system (Blank terminal)  |
| 44      | LC       | I   | Input terminal to set the low-cut function. “L”: OFF, “H”: ON. (Fixed at “H”)                                     |
| 45      | NS       | I   | Input terminal to set the noise shaving function. “L”: OFF, “H”: ON. (Fixed at “H”)                               |
| 46      | NC       | —   | Not used in this system. (Blank terminal)   |
| 47      | OSEL     | I   | Input pin for setting output sampling frequency<br>“L”: FS, “H”: 2FS (Fixed at “L” in this system)                |
| 48      | OBIT     | I   | Input terminal to set the output data word length. “L”: 16 bit, “H”: 24 bits. (Fixed at “H”)                      |
| 49      | DRO      | O   | Data output during the 8FS and 2FS modes. WCK output during FS mode.<br>Not used in this system. (Blank terminal) |
| 50      | DLO      | O   | Recording data output to CXD2656R (IC121) of the MD mechanism deck  |
| 51      | NC       | —   | Not used in this system (Blank terminal)  |
| 52, 53  | VSS      | —   | Ground  |
| 54      | BCK      | I   | Bit clock signal input (2.8224 MHz) from MD mechanism deck block CXD2656R (IC121)                                 |
| 55      | NC       | —   | Not used in this system (Blank terminal)  |
| 56      | LRCK     | I   | L/R sampling clock signal input (44.1 kHz) from MD mechanism deck block CXD2656R (IC121)                          |
| 57      | OFLG     | O   | Sync flag output terminal of output side. Not used in this system (Blank terminal)                                |
| 58      | VDD      | —   | Power supply (+5 V)   |
| 59      | OVR      | O   | Overflow flag output of R channel. Not used in this system (Blank terminal)                                       |
| 60      | OVL      | O   | Overflow flag output of L channel. Not used in this system (Blank terminal)                                       |

• AD BOARD IC800 M30624MG-215FP (SYSTEM CONTROLLER)

| Pin No.  | Pin Name             | I/O | Description  |
|----------|----------------------|-----|--|
| 1        | JOG1                 | I   | Jog dial pulse input from rotary encoder (S713 ◀◀AMS▶▶) (phase B input)  |
| 2        | JOG0                 | I   | Jog dial pulse input from rotary encoder (S713 ◀◀AMS▶▶) (phase A input)  |
| 3        | C1ERO                | O   | C1 error rate output during test mode (Blank terminal)   |
| 4        | ADERO                | O   | ADER output during test mode (Blank terminal)  |
| 5        | SQSY                 | I   | Sub code Q sync (SCOR) input from CXD2656R (IC121) Input "L" every 13.3 msec "H" is input mostly   |
| 6        | RMC                  | I   | Remote control receiving signal input form remote control receiver (IC761)   |
| 7        | A1IN                 | I   | SIRCS remote control signal input for the S-LINK control A1  |
| 8        | BYTE                 | I   | Input terminal to select the external data bus width. "L": 16 bit, "H": 8 bits. (Fixed at "L")   |
| 9        | CNVSS                | —   | Ground   |
| 10       | XIN-T                | I   | Sub system clock input (32.768 kHz)  |
| 11       | XOUT-T               | O   | Sub system clock input (32.768 kHz)  |
| 12       | $\overline{S.RST}$   | I   | System reset signal input from reset signal generator (IC240) "L": Reset. Input "L" during the several 100 ms after the power startup then change to the "H" input |
| 13       | XOUT                 | O   | Main system clock output (7 MHz)   |
| 14       | GND                  | —   | Ground   |
| 15       | XIN                  | I   | Main system clock input (7 MHz)  |
| 16       | + 3.3 V              | —   | Power supply (+3.3 V)  |
| 17       | NMI                  | I   | Non-maskable interrupt input terminal. Fixed at "H")   |
| 18       | DQSY                 | I   | Sub code Q sync (SCOR) input of digital-in U-bit CD format from CXD2656R (IC121) Input "L" every 13.3 msec "H" is input mostly                                     |
| 19       | $\overline{P.DOWN}$  | I   | Power down detection input. Input "L" when power down is detected  |
| 20       | XINT                 | I   | Interrupt status input from CXD2656R (IC121)   |
| 21       | DVOL1                | I   | Jog dial pulse input from rotary encoder (S740 REC LEVEL DEGITAL) (phase B input)  |
| 22       | DVOL0                | I   | Jog dial pulse input from rotary encoder (S740 REC LEVEL DEGITAL) (phase A input)  |
| 23       | $\overline{ADRST}$   | O   | Reset signal output to A/D converter (IC302) "L": Reset  |
| 24 to 30 | NC                   | O   | Not used in this system (Blank terminal)   |
| 31       | SWDT                 | O   | Write data output to CXD2656R (IC121) and CXD8762Q (IC501)   |
| 32       | SRDT                 | I   | Read data input from CXD2656R (IC121)  |
| 33       | SCLK                 | O   | Serial clock signal output to CXD2656R (IC121) and CXD8762Q (IC501)  |
| 34       | FLCS                 | O   | Chip select signal output to fluorescent display tube/LED drive IC (IC771) "L": Active   |
| 35       | FLDATA               | O   | Serial data output for display to fluorescent display tube/LED drive IC (IC771)  |
| 36       | NC                   | I   | Not used in this system (Fixed at "L")   |
| 37       | FLCLK                | O   | Serial data transfer clock signal output for display to fluorescent display tube/LED drive IC (IC771)  |
| 38 to 47 | NC                   | O   | Not used in this system (Blank terminal)   |
| 48       | CSET0                | I   | Initial data input terminal for the watch setting in local time. Fixed to "H"  |
| 49       | CSET1                | I   | Initial data input terminal for the watch setting in local time. Fixed to "H"  |
| 50       | 20/X720              | I   | Initial data input terminal for the loading control method. "H": IN switch is not used. (Fixed at "H")   |
| 51       | NC                   | I   | Not used in this system (Fixed at "L")   |
| 52       | MNT2 (XBUSY)         | I   | Busy monitor signal input from CXD2656R (IC121)  |
| 53       | $\overline{DIG-RST}$ | O   | Reset signal output to CXD2656R (IC121), BH6511FS (IC152), CXD8512Q (IC301) "L": Reset   |

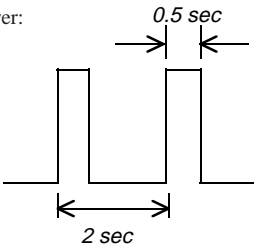
| Pin No. | Pin Name     | I/O | Description  |
|---------|--------------|-----|--|
| 54      | MNT1 (SHOCK) | I   | Track jump detection signal input from CXD2656R (IC121)  |
| 55      | SENS         | I   | Internal status (SENSE) input from CXD2656R (IC121)  |
| 56      | LDON         | O   | Laser diode ON/OFF control signal output to automatic power control circuit<br>“H”: Laser ON   |
| 57      | REFLECT      | I   | Disc reflection rate detection input from the reflect detection switch (S102). “L”: High reflection disc.<br>“H”: Low reflection disc  |
| 58      | PROTECT      | I   | Write protect detection input from the protect detection switch (S102). “H”: Write protected   |
| 59      | WR-PWR       | O   | Laser power switching signal output to CXD2656R (IC121) and HF module switch circuit<br>“L”: Playback “H”: Recording   |
| 60      | MNT3 (SLOCK) | I   | Monitor signal input of spindle servo lock from CXD2656R (IC121)   |
| 61      | SDA          | I/O | Bi-directional data bus with non-volatile memory (IC171)   |
| 62      | + 3.3 V      | O   | Power supply (+3.3 V)  |
| 63      | NC           | —   | Not used in this system (Blank terminal)   |
| 64      | GND          | O   | Ground   |
| 65      | SCTX         | O   | Recording data output enable signal output to CXD2656 (IC121).<br>The transmission timing of the writing data is output. (Used as ON/OFF of magnetic head too)   |
| 66      | SCL          | I   | Clock signal output to non-volatile memory (IC171)   |
| 67      | MNT0 (FOK)   | I   | Focus OK signal is input from CXD2656R (IC121). “H” is input when focus is locked. (“L”: NG)   |
| 68      | LIMIT-IN     | O   | Input signal from the sled limit in detection switch (S101).<br>“L”: Sled limit in (when optical pickup comes to the innermost circumference)  |
| 69      | MOD          | O   | Laser modulation selector signal output to the HP module switch circuit.<br>During playback power: “H”, During stop: “L”,<br>During recording power:<br> |
| 70      | XLATCH       | O   | Serial data latch pulse output to CXD2656R (IC121)   |
| 71      | REC/PB       | O   | Not used in this system (Blank terminal)   |
| 72      | TECONT       | I   | Not used in this system (Fixed at “L”)   |
| 73      | XTSL         | I   | Not used in this system (Fixed at “L”)   |
| 74      | PB-P         | I   | Playback position detection switch (S10) input “L”: Active   |
| 75      | CHACK IN     | I   | Input signal from the playback switch position detect switch (S10). “L”: active.   |
| 76      | PACK-OUT     | I   | Input signal from disc chucking in detection switch (S11). “L”: active   |
| 77      | REC-P        | I   | Recording position detection switch (S13) input “L”: Active  |
| 78      | LDIN         | O   | Loading motor control signal output to motor drive IC (IC250)  |
| 79      | LDOUT        | O   | “L”: Active *1   |
| 80      | LD-LOW       | O   | Loading motor drive voltage control signal output to motor drive IC (IC250)<br>“H”: Active   |
| 81      | NC           | O   | Not used in this system (Blank terminal)   |

\* 1 Loading motor (M10) control

| Pin            | Mode    |       |      |       |
|----------------|---------|-------|------|-------|
|                | Loading | Eject | Stop | Brake |
| LDIN (78-pin)  | “L”     | “H”   | “H”  | “L”   |
| LDOUT (79-pin) | “H”     | “L”   | “H”  | “L”   |

| Pin No. | Pin Name   | I/O | Description  |
|---------|------------|-----|--|
| 82      | A1OUT      | O   | SIRCS remote control signal input for the S-LINK control A1  |
| 83      | MUTE       | O   | Audio line muting control signal output<br>“L”: Line muting ON   |
| 84      | STB        | O   | Strobe control signal output to power supply circuit<br>“L”: Standby mode, “H”: Power ON   |
| 85      | COAX/XOPT  | O   | Selection signal output of optical 1/2 input or coaxial input to digital input signal selector (IC405)<br>L: Digital optical 1/2 input, “H”: Coaxial input |
| 86      | OPT2/XOPT1 | O   | Selection signal output of optical 1/2 input to digital input signal selector (IC405)<br>L: Digital optical 1 input, “H”: Digital optical 2 input          |
| 87      | DALATCH    | O   | Serial data latch pulse output to CXD8762Q (IC501)   |
| 88      | DARST      | O   | Reset signal output to CXD8762Q (IC501) “L”: Reset   |
| 89      | LED0       | O   | Drive signal output to ■ (PAUSE) LED (D754) “L”: LED ON  |
| 90      | LED1       | O   | Drive signal output to ● REC LED (D755) “L”: LED ON  |
| 91      | TIMER      | I   | Timer switch (S751) input (A/D input)<br>“L”: PLAY, “H”: REC (middle point voltage: OFF)   |
| 92      | SOURCE     | I   | INPUT switch (S741) input (A/D input)  |
| 93      | KEY3       | I   | Key input (A/D input)<br>S731 to S734 (TIME, FADER, FILTER, MEGA CONTROL key input)  |
| 94      | KEY2       | I   | Key input (A/D input)<br>S722 to S726 (PLAY/MODE, REPEAT, SCROLL/CLOCK SET, DISPLAY/CHAR, I/⏻ key input)   |
| 95      | KEY1       | I   | Key input (A/D input)<br>S711 to S714, S716 (MENU/NO, YES, PUSH ENTER, CLEAR, ≡ OPEN/CLOSE key input)  |
| 96      | AVSS       | —   | Ground (for A/D converter)   |
| 97      | KEY0       | I   | Key input (A/D input) S701 to S706 (REC ●, ■, ▶▶, ◀◀, ■■, ▶ key input)   |
| 98      | VREF       | I   | Reference voltage (+3.3 V) input (for A/D converter)   |
| 99      | + 3.3V     | —   | Power supply (+3.3 V)  |
| 100     | MONO/ST    | I   | Recording mode switch input “L”: MONO, “H”: STEREO<br>Not used in this system (Fixed at “H”)   |

## SECTION 7 EXPLODED VIEWS

**NOTE:**

- -XX, -X mean standardized parts, so they may have some differences from the original one.
- Items marked “\*” are not stocked since they are seldom required for routine service. Some delay should be anticipated when ordering these items.
- Color Indication of Appearance Parts Example:  
 KNOB, BALANCE (WHITE) . . . (RED)  
   ↑  ↑  
   Parts of Color Cabinet's Color

- The mechanical parts with no reference number in the exploded views are not supplied.
- Hardware (# mark) list and accessories and packing materials are given in the last of this parts list.
- Abbreviation  
 CND : Canadian model

The components identified by mark  $\Delta$  or dotted line with mark  $\Delta$  are critical for safety. Replace only with part number specified.

Les composants identifiés par une marque  $\Delta$  sont critiques pour la sécurité. Ne les remplacer que par une pièce portant le numéro spécifié.

### 7-1. UPPER CASE ASSEMBLY

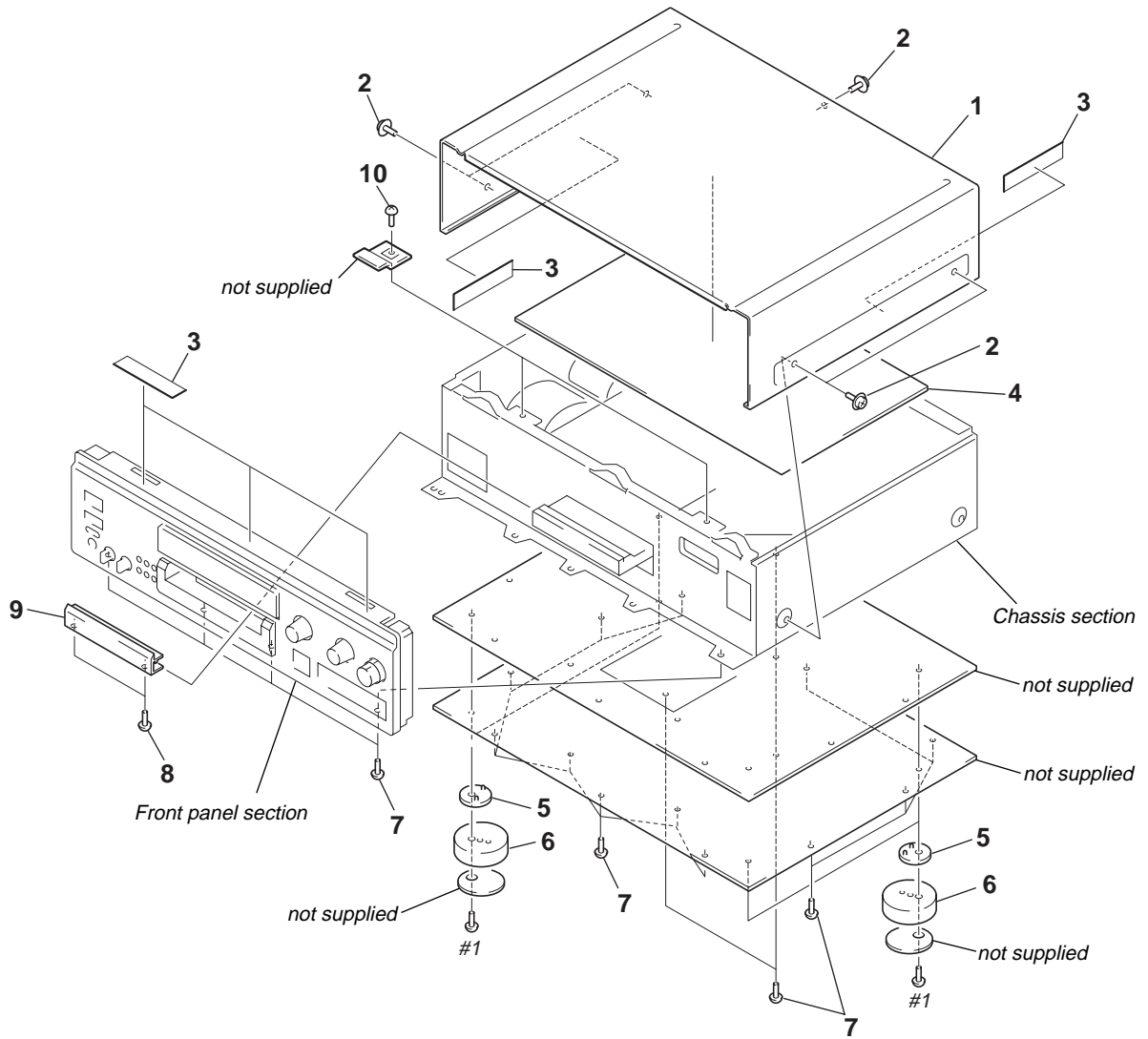

| Ref. No. | Part No.     | Description               | Remarks | Ref. No. | Part No.     | Description            | Remarks |
|----------|--------------|---------------------------|---------|----------|--------------|------------------------|---------|
| 1        | 4-220-301-01 | CASE (GOLD)               |         | 6        | 4-970-487-01 | FOOT (F50180S)         |         |
| 1        | 4-220-301-11 | CASE (BLACK)              |         | 7        | 4-929-074-01 | SCREW (3 × 8)          |         |
| 2        | 4-210-291-01 | SCREW (CASE 3 TP2)(BLACK) |         | 8        | 3-946-435-11 | SCREW (M2.6)(GOLD)     |         |
| 2        | 4-210-291-11 | SCREW (CASE 3 TP2)(GOLD)  |         | 8        | 3-946-435-21 | SCREW (M2.6)(BLACK)    |         |
| * 3      | 4-615-354-01 | SPACER                    |         | 9        | 4-220-290-01 | PANEL, LOADING (GOLD)  |         |
| * 4      | 4-974-014-01 | REINFORCEMENT (CASE)      |         | 9        | 4-220-290-11 | PANEL, LOADING (BLACK) |         |
| 5        | 4-970-488-01 | SPACER (F50180S)          |         | 10       | 4-974-510-01 | SCREW (+BW 3 × 8 CU)   |         |

## 7-2. FRONT PANEL ASSEMBLY

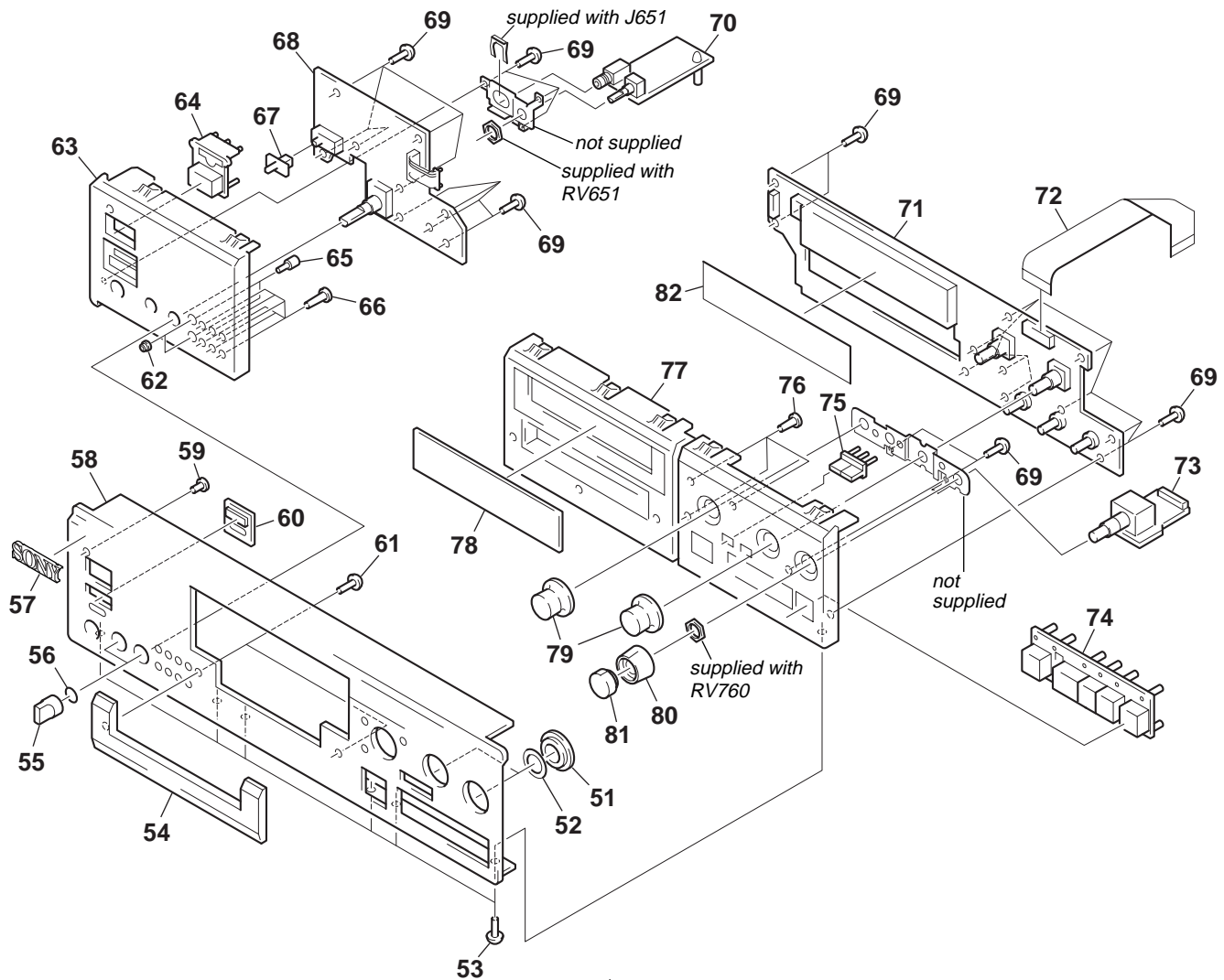

| Ref. No. | Part No.     | Description                    | Remarks | Ref. No. | Part No.     | Description                 | Remarks |
|----------|--------------|--------------------------------|---------|----------|--------------|-----------------------------|---------|
| 51       | 4-220-295-01 | RING (REC), ORNAMENTAL (GOLD)  |         | 68       | A-4724-792-A | PSW BOARD, COMPLETE(AEP,UK) |         |
| 51       | 4-220-295-11 | RING (REC), ORNAMENTAL (BLACK) |         | 68       | A-4724-793-A | PSW BOARD, COMPLETE(US,CND) |         |
| 52       | 4-220-312-01 | SHEET (RING), ADHESIVE         |         | 69       | 4-951-620-01 | SCREW (2.6 × 8), +BVTP      |         |
| 53       | 4-929-074-01 | SCREW (3 × 8)                  |         | 70       | 1-674-323-11 | HP BOARD                    |         |
| 54       | 4-220-291-01 | ESCUTCHEON (MD)(GOLD)          |         | 71       | A-4724-789-A | FL BOARD, COMPLETE (AEP,UK) |         |
| 54       | 4-220-291-11 | ESCUTCHEON (MD)(BLACK)         |         | 71       | A-4724-790-A | FL BOARD, COMPLETE (US,CND) |         |
| 55       | 4-992-539-01 | KNOB (VOL)(GOLD)               |         | 72       | 1-791-547-11 | WIRE (FLAT TYPE) (25CORE)   |         |
| 55       | 4-992-539-11 | KNOB (VOL)(BLACK)              |         | 73       | 1-674-328-11 | REC BOARD                   |         |
| 56       | 3-354-981-01 | SPRING (SUS), RING             |         | 74       | X-4951-690-1 | BUTTON (PLAY) ASSY (GOLD)   |         |
| 57       | 4-942-568-41 | EMBLEM (NO.5), SONY(BLACK)     |         | 74       | X-4951-691-1 | BUTTON (PLAY) ASSY (BLACK)  |         |
| 58       | 4-220-325-01 | PANEL, FRONT (GOLD)            |         | 75       | 4-220-321-01 | BUTTON (FR)(GOLD)           |         |
| 58       | 4-220-325-11 | PANEL, FRONT (BLACK) (AEP,UK)  |         | 75       | 4-220-321-11 | BUTTON (FR)(BLACK)          |         |
| 58       | 4-220-325-21 | PANEL, FRONT (BLACK) (US,CND)  |         | 76       | 4-220-320-01 | BUTTON (EDIT)(GOLD)         |         |
| 59       | 4-987-519-01 | INDICATOR (D2)                 |         | 76       | 4-220-320-11 | BUTTON (EDIT)(BLACK)        |         |
| 60       | 4-987-520-01 | WINDOW (REMOTE CONTROL)(GOLD)  |         | 77       | 4-220-316-01 | BASE(R), PANEL (GOLD)       |         |
| 60       | 4-987-520-11 | WINDOW (REMOTE CONTROL)(BLACK) |         | 77       | 4-220-316-11 | BASE(R), PANEL (BLACK)      |         |
| 61       | 3-701-428-31 | SCREW, +B 2.6 CLAW             |         | 78       | 4-220-323-01 | WINDOW (FL)(GOLD)           |         |
| 62       | 4-220-711-01 | INDICATOR (FILTER)             |         | 78       | 4-220-323-11 | WINDOW (FL)(BLACK)          |         |
| 63       | 4-220-315-01 | BASE (L), PANEL (GOLD)         |         | 79       | 4-220-292-01 | KNOB (AMS)(GOLD)            |         |
| 63       | 4-220-315-11 | BASE (L), PANEL (BLACK)        |         | 79       | 4-220-292-11 | KNOB (AMS)(BLACK)           |         |
| 64       | 4-998-737-01 | BUTTON (POWER)(GOLD)           |         | 80       | 4-220-293-01 | KNOB (REC-L)(GOLD)          |         |
| 64       | 4-998-737-11 | BUTTON (POWER)(BLACK)          |         | 80       | 4-220-293-11 | KNOB (REC-L)(BLACK)         |         |
| 66       | 4-220-319-01 | BUTTON (MODE)(GOLD)            |         | 81       | 4-220-294-01 | KNOB (REC-R)(GOLD)          |         |
| 66       | 4-220-319-11 | BUTTON (MODE)(BLACK)           |         | 81       | 4-220-294-11 | KNOB (REC-R)(BLACK)         |         |
| 67       | 4-971-774-01 | KNOB (TIMER)(BLACK)            |         | 82       | 4-220-324-01 | FILTER (FL)(UK,AEP)         |         |
| 67       | 4-971-774-21 | KNOB (TIMER)(GOLD)             |         |          |              |                             |         |



### 7-3. CHASSIS ASSEMBLY

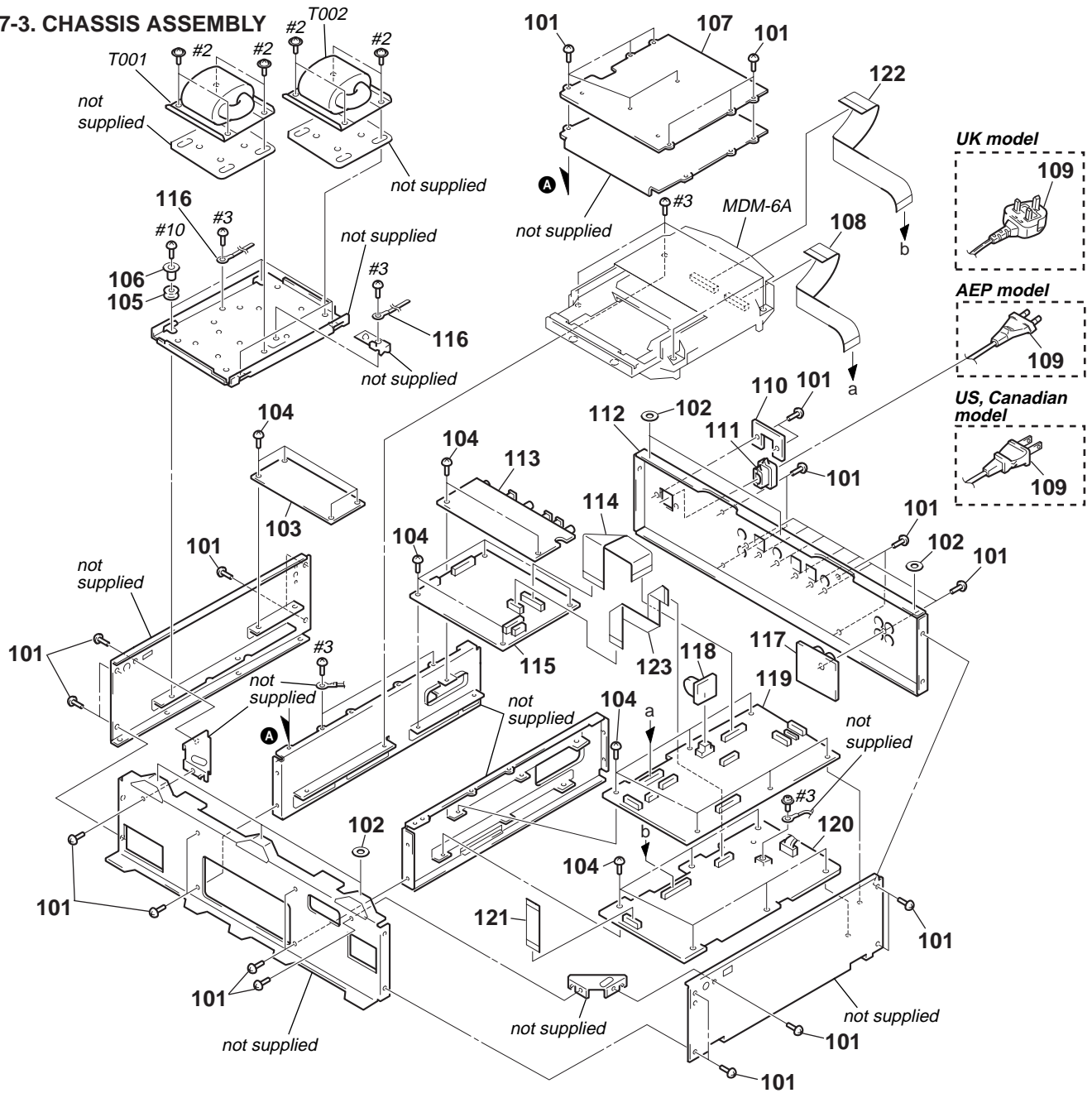

| Ref. No. | Part No.     | Description                 | Remarks | Ref. No. | Part No.     | Description                | Remarks |
|----------|--------------|-----------------------------|---------|----------|--------------|----------------------------|---------|
| 101      | 4-929-074-01 | SCREW (3 × 8)               |         | 115      | A-4724-804-A | PW BOARD, COMPLETE(AEP,UK) |         |
| 102      | 4-971-099-01 | WASHER (P)                  |         | 115      | A-4724-805-A | PW BOARD, COMPLETE(US,CND) |         |
| 103      | 1-674-321-11 | AC BOARD                    |         | * 116    | 3-703-150-11 | CLAMP                      |         |
| 104      | 4-974-510-01 | SCREW (+BV 3 × 8 CU)        |         | 117      | 1-674-324-11 | PJ BOARD                   |         |
| * 105    | 4-888-798-00 | BUSHING, RUBBER             |         | 118      | 1-674-325-11 | BT BOARD                   |         |
| 106      | 4-928-032-01 | COLLAR (A)                  |         | 119      | A-4724-798-A | AD BOARD, COMPLETE(AEP,UK) |         |
| 107      | 4-214-292-11 | COVER (MDM-T)               |         | 119      | A-4724-799-A | AD BOARD, COMPLETE(US,CND) |         |
| 108      | 1-790-202-11 | WIRE (FLAT TYPE) (23 CORE)  |         | 120      | A-4724-801-A | DA BOARD, COMPLETE(AEP,UK) |         |
| △ 109    | 1-558-568-21 | CORD, POWER(AEP)            |         | 120      | A-4724-802-A | DA BOARD, COMPLETE(US,CND) |         |
| △ 109    | 1-559-583-21 | CORD, POWER(US,CND)         |         | 121      | 1-790-205-11 | WIRE (FLAT TYPE) (17 CORE) |         |
| △ 109    | 1-696-586-11 | CORD, POWER(UK)             |         | 122      | 1-791-168-11 | WIRE(FLAT TYPE) (27 CORE)  |         |
| * 110    | 4-923-873-01 | BRACKET, CORD STOPPER       |         | 123      | 1-791-167-11 | WIRE(FLAT TYPE) (13 CORE)  |         |
| 111      | 3-703-244-00 | BUSHING (2104), CORD        |         | △ T001   | 1-433-987-11 | TRANSFORMER, POWER(US,CND) |         |
| 112      | 4-220-300-11 | PANEL, BACK(UK,AEP)         |         | △ T001   | 1-433-989-11 | TRANSFORMER, POWER(UK,AEP) |         |
| 112      | 4-220-300-21 | PANEL, BACK(US)             |         | △ T002   | 1-433-988-11 | TRANSFORMER, POWER(US,CND) |         |
| 112      | 4-220-300-31 | PANEL, BACK(CND)            |         | △ T002   | 1-433-990-11 | TRANSFORMER, POWER(UK,AEP) |         |
| 113      | A-4724-810-A | DIG BOARD, COMPLETE(AEP,UK) |         |          |              |                            |         |
| 113      | A-4724-811-A | DIG BOARD, COMPLETE(US,CND) |         |          |              |                            |         |
| 114      | 1-791-166-11 | WIRE(FLAT TYPE) (21 CORE)   |         |          |              |                            |         |

The components identified by mark △ or dotted line with mark △ are critical for safety. Replace only with part number specified.

Les composants identifiés par une marque △ sont critiques pour la sécurité. Ne les remplacer que par une pièce portant le numéro spécifié.

## 7-4. MECHANISM DECK ASSEMBLY-1 (MDM-6A)

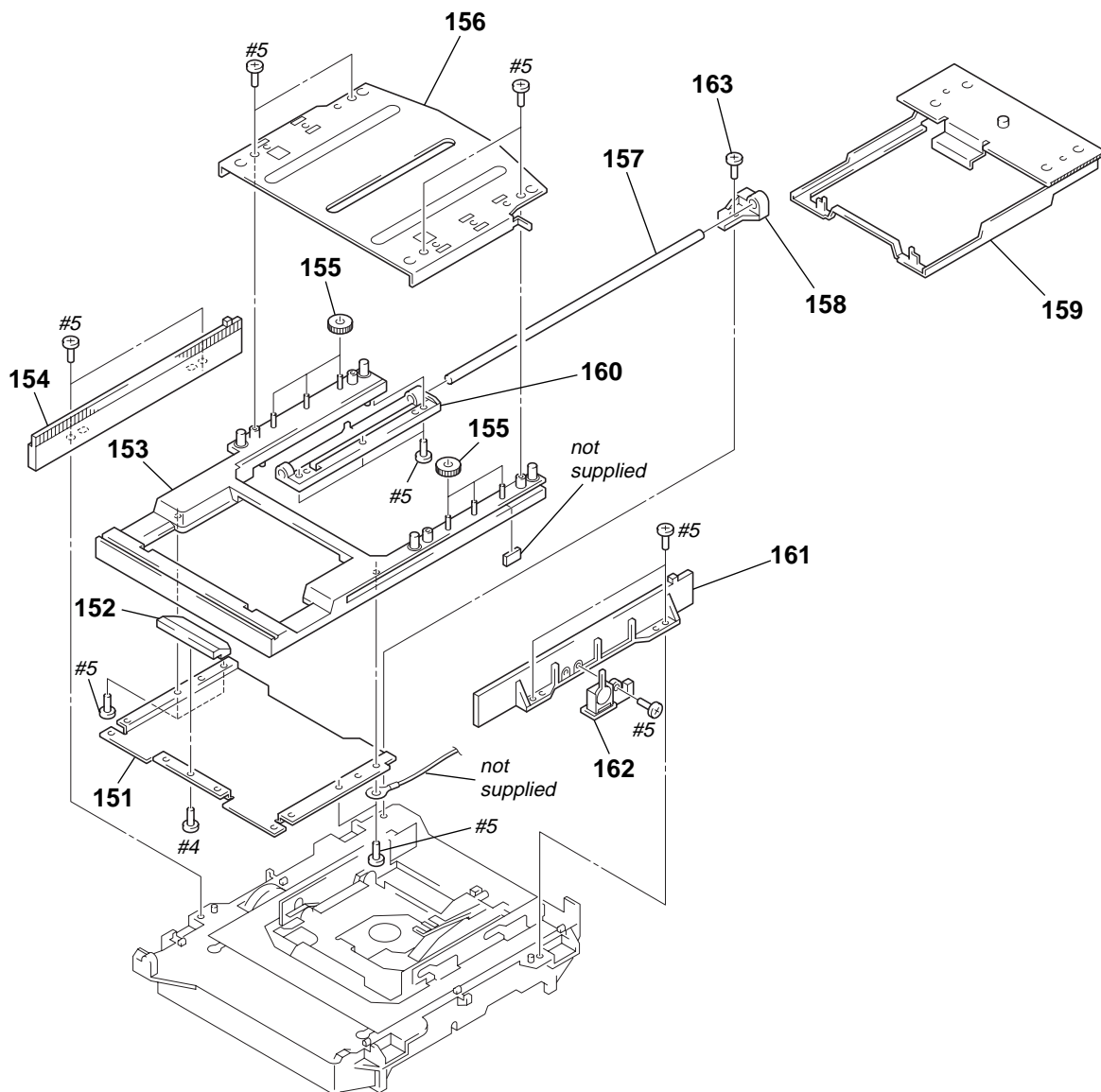

| Ref. No. | Part No.     | Description    | Remarks | Ref. No. | Part No.     | Description        | Remarks |
|----------|--------------|----------------|---------|----------|--------------|--------------------|---------|
| * 151    | 4-999-519-01 | BRACKET (TRAY) |         | 158      | 4-987-271-01 | STOPPER (SHAFT B)  |         |
| * 152    | 4-987-267-01 | TABLE (EJECT)  |         | 159      | X-4949-787-1 | SLIDER (D) ASSY    |         |
| 153      | 4-999-509-01 | TRAY           |         | 160      | 4-999-512-01 | GUIDE (SHAFT)      |         |
| 154      | 4-999-528-01 | RACK (L)       |         | 161      | 4-999-529-01 | RACK (R)           |         |
| 155      | 4-999-544-01 | GEAR (TOP)     |         | * 162    | 1-669-050-11 | OUT SWITCH BOARD   |         |
| * 156    | 4-999-532-01 | BRACKET (TOP)  |         | 163      | 4-951-620-41 | SCREW (2.6), +BVTP |         |
| 157      | 4-999-535-01 | SHAFT          |         |          |              |                    |         |

### 7-5. MECHANISM DECK ASSEMBLY-2 (MDM-6A)

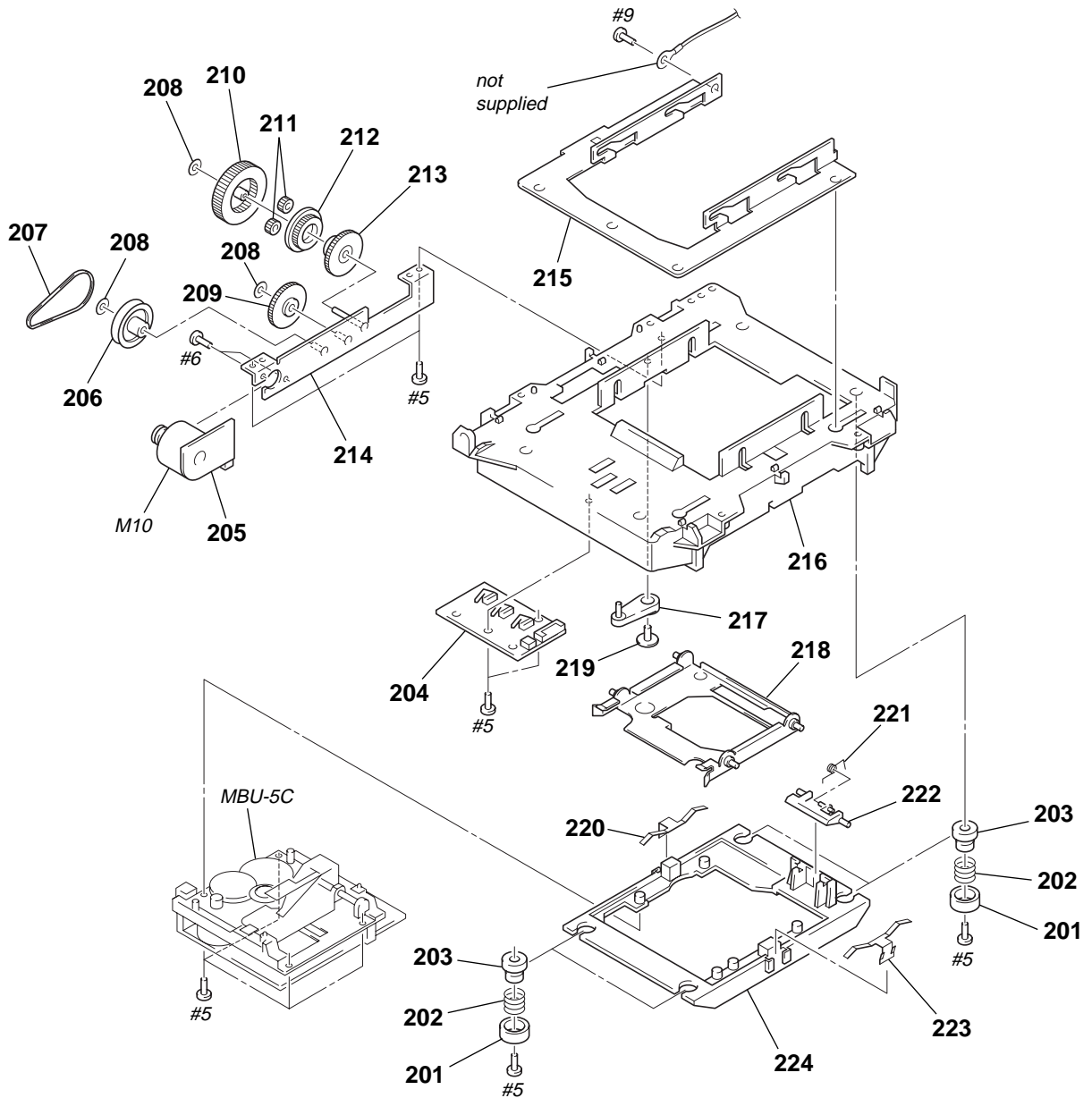

| Ref. No. | Part No.     | Description           | Remarks | Ref. No. | Part No.     | Description             | Remarks |
|----------|--------------|-----------------------|---------|----------|--------------|-------------------------|---------|
| 201      | 4-999-541-01 | COLLAR (DAMPER)       |         | 213      | 4-999-516-01 | GEAR (B), PLANET        |         |
| 202      | 4-999-539-01 | SPRING, COMPRESSION   |         | * 214    | X-4949-788-1 | BRACKET (MOTOR) ASSY    |         |
| 203      | 4-999-540-01 | INSULATOR (MD)        |         | 215      | X-4949-786-5 | SLIDER ASSY             |         |
| * 204    | 1-669-051-11 | POSITION SWITCH BOARD |         | 216      | 4-999-527-01 | CHASSIS, MECHANICAL     |         |
| * 205    | 1-669-049-11 | MOTOR BOARD           |         | 217      | X-4949-790-1 | LEVER (LOCK) ASSY       |         |
| 206      | 4-999-513-01 | GEAR, PULLEY          |         | 218      | X-4949-789-1 | HOLDER ASSY             |         |
| 207      | 4-999-537-01 | BELT (LOADING)        |         | 219      | 4-933-134-01 | SCREW (+PTPWH M2.6 × 6) |         |
| 208      | 4-968-919-31 | WASHER, STOPPER       |         | 220      | 4-999-533-01 | SPRING (UDL), LEAF      |         |
| 209      | 4-999-514-01 | GEAR                  |         | 221      | 4-999-524-01 | SPRING (OWH), TORSION   |         |
| 210      | 4-999-515-01 | GEAR (A), PLANET      |         | 222      | 4-999-511-01 | LEVER (OWH)             |         |
| 211      | 4-999-518-01 | GEAR (D), PLANET      |         | 223      | 4-999-534-01 | SPRING (UDR), LEAF      |         |
| 212      | 4-999-517-01 | GEAR (C), PLANET      |         | 224      | 4-999-510-01 | HOLDER, BU              |         |
|          |              |                       |         | M10      | X-4949-791-1 | MOTOR (LOADING) ASSY    |         |

## 7-6. BASE UNIT (MBU-5C)

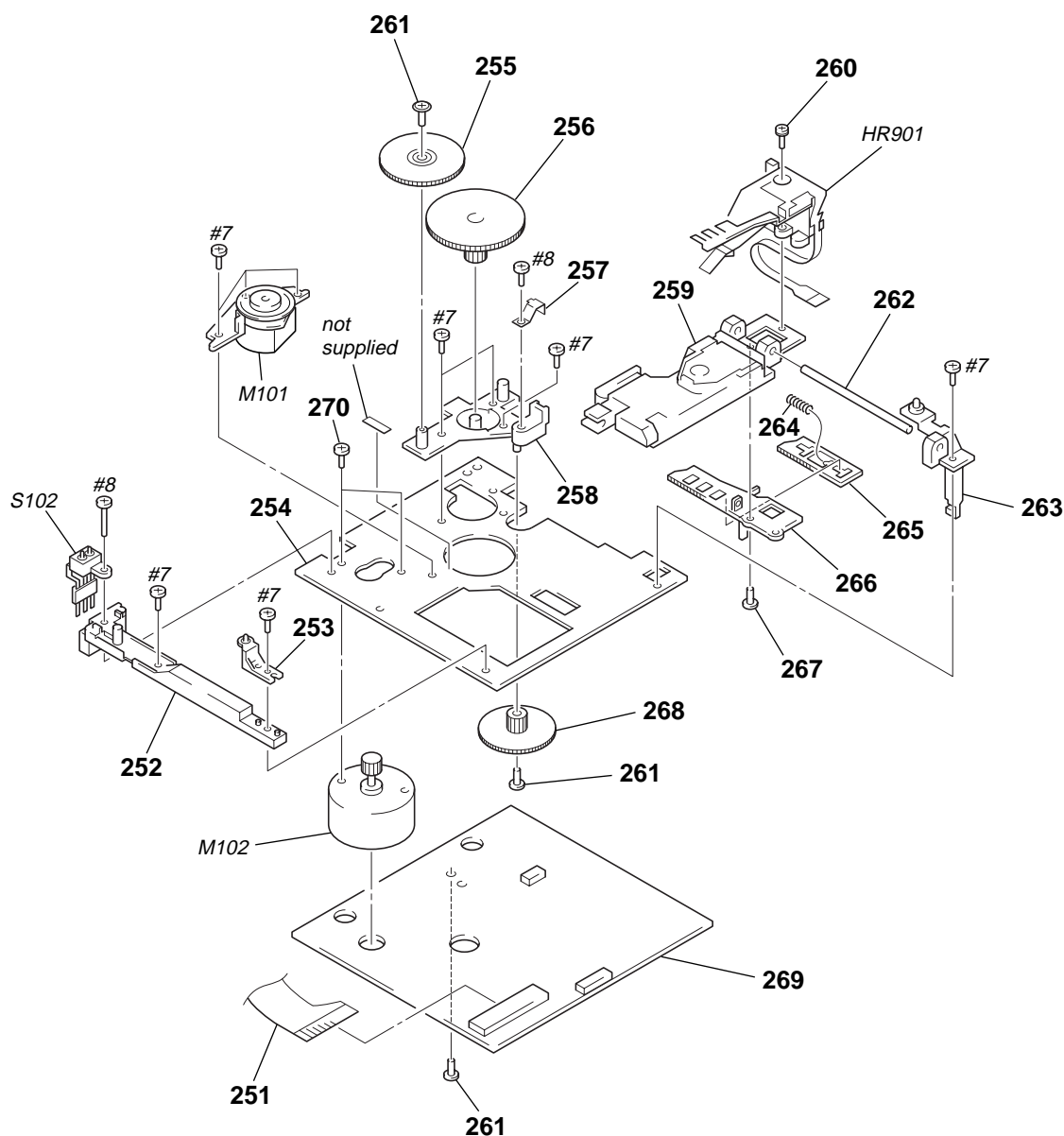

| Ref. No. | Part No.     | Description                  | Remarks | Ref. No. | Part No.     | Description             | Remarks |
|----------|--------------|------------------------------|---------|----------|--------------|-------------------------|---------|
| 251      | 1-667-954-11 | PC BOARD, FLEXIBLE           |         | * 263    | 4-210-664-01 | BASE (BU-A)             |         |
| * 252    | 4-996-255-01 | BASE (BU-C)                  |         | 264      | 4-996-258-01 | SPRING, COMPRESSION     |         |
| * 253    | 4-996-267-01 | BASE (BU-D)                  |         | 265      | 4-996-257-01 | RACK (SL)               |         |
| * 254    | 4-996-252-01 | CHASSIS, BU                  |         | 266      | 4-996-256-01 | SL (BASE)               |         |
| 255      | 4-996-260-01 | GEAR (SL-A)                  |         | 267      | 4-900-590-01 | SCREW, PRECISION SMALL  |         |
| 256      | 4-996-261-01 | GEAR (SL-B)                  |         | 268      | 4-996-262-01 | GEAR (SL-C)             |         |
| 257      | 4-996-263-01 | SPRING (CLV), TORSION        |         | * 269    | A-4724-285-A | BD BOARD, COMPLETE      |         |
| * 258    | 4-996-254-01 | BASE (BU-B)                  |         | 270      | 4-211-036-01 | SCREW (1.7 x 2.5), +PWH |         |
| △ 259    | A-4672-541-A | OPTICAL PICK UP KMS-260B/J1N |         | HR901    | 1-500-565-11 | HEAD, OVER LIGHT        |         |
| 260      | 4-988-560-01 | SCREW (+P 1.7 x 6)           |         | M101     | A-4672-475-A | MOTOR ASSY, SPINDLE     |         |
| 261      | 3-372-761-01 | SCREW (M1.7), TAPPING        |         | M102     | A-4672-474-A | MOTOR ASSY, SLED        |         |
| 262      | 4-996-265-01 | SHAFT, MAIN                  |         | S102     | 1-762-148-21 | SWITCH, PUSH (2 KEY)    |         |

(REFLECT/PROTECT DET.)

The components identified by mark  $\Delta$  or dotted line with mark  $\Delta$  are critical for safety. Replace only with part number specified.

Les composants identifiés par une marque  $\Delta$  sont critiques pour la sécurité. Ne les remplacer que par une pièce portant le numéro spécifié.

## SECTION 8 ELECTRICAL PARTS LIST

AC

AD

**NOTE:**

- Due to standardization, replacements in the parts list may be different from the parts specified in the diagrams or the components used on the set.
- -XX, -X mean standardized parts, so they may have some difference from the original one.
- Items marked "\*" are not stocked since they are seldom required for routine service. Some delay should be anticipated when ordering these items.
- Abbreviation  
CND : Canadian model

- CAPACITORS:  
uF:  $\mu$ F
- RESISTORS  
All resistors are in ohms.  
METAL: metal-film resistor  
METAL OXIDE: Metal Oxide-film resistor  
F: nonflammable
- COILS  
uH:  $\mu$ H

- SEMICONDUCTORS  
In each case, u:  $\mu$ , for example:  
uA...:  $\mu$ A..., uPA...,  $\mu$ PA...,  
uPB...,  $\mu$ PB..., uPC...,  $\mu$ PC...,  
uPD...,  $\mu$ PD...

The components identified by mark  $\Delta$  or dotted line with mark  $\Delta$  are critical for safety. Replace only with part number specified.

Les composants identifiés par une marque  $\Delta$  sont critiques pour la sécurité. Ne les remplacer que par une pièce portant le numéro spécifié.

When indicating parts by reference number, please include the board name.

| Ref. No.       | Part No.     | Description                         | Remarks           | Ref. No. | Part No.     | Description  | Remarks         |
|----------------|--------------|-------------------------------------|-------------------|----------|--------------|--------------|-----------------|
|                | 1-674-321-11 | AC BOARD<br>*****                   |                   |          |              |              |                 |
|                |              | < CAPACITOR >                       |                   |          |              |              |                 |
| $\Delta$ C002  | 1-113-920-11 | CERAMIC                             | 0.0022uF 20% 250V | C318     | 1-164-732-11 | CERAMIC      | 0.1uF 20% 50V   |
| $\Delta$ C003  | 1-113-920-11 | CERAMIC                             | 0.0022uF 20% 250V | C319     | 1-110-495-11 | ELECT        | 220uF 20% 25V   |
| $\Delta$ C004  | 1-113-920-11 | CERAMIC                             | 0.0022uF 20% 250V | C320     | 1-164-732-11 | CERAMIC      | 0.1uF 20% 50V   |
| $\Delta$ C005  | 1-113-925-11 | CERAMIC                             | 0.01uF 20% 250V   | C321     | 1-126-103-11 | ELECT        | 470uF 20% 16V   |
| $\Delta$ C006  | 1-113-925-11 | CERAMIC                             | 0.01uF 20% 250V   | C322     | 1-126-103-11 | ELECT        | 470uF 20% 16V   |
| $\Delta$ C007  | 1-113-925-11 | CERAMIC                             | 0.01uF 20% 250V   | C323     | 1-164-732-11 | CERAMIC      | 0.1uF 20% 50V   |
| $\Delta$ C008  | 1-113-925-11 | CERAMIC                             | 0.01uF 20% 250V   | C324     | 1-164-732-11 | CERAMIC      | 0.1uF 20% 50V   |
|                |              | < CONNECTOR >                       |                   | C325     | 1-164-732-11 | CERAMIC      | 0.1uF 20% 50V   |
| * CN002        | 1-580-230-11 | PIN, CONNECTOR (PC BOARD) 2P        |                   | C326     | 1-164-732-11 | CERAMIC      | 0.1uF 20% 50V   |
| CN003          | 1-564-321-00 | PIN, CONNECTOR 2P                   |                   | C327     | 1-128-201-11 | ELECT        | 100uF 20% 50V   |
| * CN004        | 1-564-321-21 | PIN, CONNECTOR 2P                   |                   | C328     | 1-128-201-11 | ELECT        | 100uF 20% 50V   |
|                |              | < PLATE >                           |                   | C329     | 1-124-698-81 | ELECT        | 100uF 20% 25V   |
| * EP001        | 4-870-539-00 | PLATE, GROUND                       |                   | C330     | 1-124-698-81 | ELECT        | 100uF 20% 25V   |
|                |              | < LINE FILTER >                     |                   | C331     | 1-124-698-81 | ELECT        | 100uF 20% 25V   |
| $\Delta$ LF001 | 1-424-485-11 | FILTER, LINE                        |                   | C332     | 1-124-698-81 | ELECT        | 100uF 20% 25V   |
| $\Delta$ LF002 | 1-424-485-11 | FILTER, LINE                        |                   | C333     | 1-110-495-11 | ELECT        | 220uF 20% 25V   |
| *****          |              |                                     |                   | C334     | 1-110-495-11 | ELECT        | 220uF 20% 25V   |
|                | A-4724-798-A | AD BOARD, COMPLETE(AEP,UK)<br>***** |                   | C335     | 1-124-698-81 | ELECT        | 100uF 20% 25V   |
|                | A-4724-799-A | AD BOARD, COMPLETE(US,CND)<br>***** |                   | C336     | 1-124-698-81 | ELECT        | 100uF 20% 25V   |
|                |              | < CAPACITOR >                       |                   | C338     | 1-162-199-31 | CERAMIC      | 10PF 5% 50V     |
| C302           | 1-164-159-11 | CERAMIC                             | 0.1uF 50V         | C340     | 1-126-022-11 | ELECT        | 47uF 20% 25V    |
| C303           | 1-164-159-11 | CERAMIC                             | 0.1uF 50V         | C800     | 1-163-251-11 | CERAMIC CHIP | 100PF 5% 50V    |
| C304           | 1-126-934-11 | ELECT                               | 220uF 20% 10V     | C801     | 1-163-251-11 | CERAMIC CHIP | 100PF 5% 50V    |
| C305           | 1-164-159-11 | CERAMIC                             | 0.1uF 50V         | C802     | 1-163-009-11 | CERAMIC CHIP | 0.001uF 10% 50V |
| C306           | 1-162-294-31 | CERAMIC                             | 0.001uF 10% 50V   | C803     | 1-163-251-11 | CERAMIC CHIP | 100PF 5% 50V    |
| C307           | 1-164-159-11 | CERAMIC                             | 0.1uF 50V         | C804     | 1-163-251-11 | CERAMIC CHIP | 100PF 5% 50V    |
| C308           | 1-164-159-11 | CERAMIC                             | 0.1uF 50V         | C805     | 1-163-009-11 | CERAMIC CHIP | 0.001uF 10% 50V |
| C309           | 1-164-159-11 | CERAMIC                             | 0.1uF 50V         | C806     | 1-163-038-91 | CERAMIC CHIP | 0.1uF 25V       |
| C310           | 1-164-159-11 | CERAMIC                             | 0.1uF 50V         | C807     | 1-163-038-91 | CERAMIC CHIP | 0.1uF 25V       |
| C311           | 1-164-159-11 | CERAMIC                             | 0.1uF 50V         | C808     | 1-163-038-91 | CERAMIC CHIP | 0.1uF 25V       |
| C313           | 1-164-732-11 | CERAMIC                             | 0.1uF 20% 50V     | C809     | 1-163-231-11 | CERAMIC CHIP | 15PF 5% 50V     |
| C314           | 1-164-732-11 | CERAMIC                             | 0.1uF 20% 50V     | C810     | 1-163-231-11 | CERAMIC CHIP | 15PF 5% 50V     |
| C315           | 1-164-732-11 | CERAMIC                             | 0.1uF 20% 50V     | C811     | 1-163-038-91 | CERAMIC CHIP | 0.1uF 25V       |
| C316           | 1-136-820-11 | FILM                                | 0.01uF 5% 100V    | C812     | 1-163-038-91 | CERAMIC CHIP | 0.1uF 25V       |
| C317           | 1-136-820-11 | FILM                                | 0.01uF 5% 100V    | C813     | 1-163-009-11 | CERAMIC CHIP | 0.001uF 10% 50V |
|                |              |                                     |                   | C814     | 1-163-009-11 | CERAMIC CHIP | 0.001uF 10% 50V |
|                |              |                                     |                   | C815     | 1-163-009-11 | CERAMIC CHIP | 0.001uF 10% 50V |
|                |              |                                     |                   | C816     | 1-163-009-11 | CERAMIC CHIP | 0.001uF 10% 50V |
|                |              |                                     |                   | C817     | 1-131-347-00 | TANTALUM     | 1uF 10% 35V     |
|                |              |                                     |                   | C818     | 1-163-038-91 | CERAMIC CHIP | 0.1uF 25V       |
|                |              |                                     |                   | C819     | 1-126-925-11 | ELECT        | 470uF 20% 10V   |
|                |              |                                     |                   | C820     | 1-163-038-91 | CERAMIC CHIP | 0.1uF 25V       |
|                |              |                                     |                   | C824     | 1-163-251-11 | CERAMIC CHIP | 100PF 5% 50V    |
|                |              |                                     |                   | C825     | 1-163-038-91 | CERAMIC CHIP | 0.1uF 25V       |
|                |              |                                     |                   | C850     | 1-126-925-11 | ELECT        | 470uF 20% 10V   |

| Ref. No. | Part No.     | Description                    | Remarks | Ref. No. | Part No. | Description    | Remarks                  |                |
|----------|--------------|--------------------------------|---------|----------|----------|----------------|--------------------------|----------------|
| C851     | 1-163-038-91 | CERAMIC CHIP                   | 0.1uF   | 25V      |          | < COIL >       |                          |                |
| C852     | 1-131-347-00 | TANTALUM                       | 1uF     | 10%      | 35V      |                |                          |                |
| C853     | 1-126-934-11 | ELECT                          | 220uF   | 20%      | 10V      |                |                          |                |
| C854     | 1-163-038-91 | CERAMIC CHIP                   | 0.1uF   | 25V      | L301     | 1-408-599-31   | INDUCTOR 4.7uH           |                |
| C855     | 1-126-022-11 | ELECT                          | 47uF    | 20%      | 25V      | L302           | 1-408-599-31             | INDUCTOR 4.7uH |
| C856     | 1-163-038-91 | CERAMIC CHIP                   | 0.1uF   | 25V      | L850     | 1-408-599-31   | INDUCTOR 4.7uH           |                |
| C858     | 1-163-038-91 | CERAMIC CHIP                   | 0.1uF   | 25V      | L851     | 1-408-599-31   | INDUCTOR 4.7uH           |                |
| C859     | 1-163-038-91 | CERAMIC CHIP                   | 0.1uF   | 25V      | L852     | 1-414-235-22   | INDUCTOR CHIP OUH        |                |
| C860     | 1-163-038-91 | CERAMIC CHIP                   | 0.1uF   | 25V      |          | < TRANSISTOR > |                          |                |
| C861     | 1-163-038-91 | CERAMIC CHIP                   | 0.1uF   | 25V      | Q880     | 8-729-027-23   | TRANSISTOR RT1P141C-TP-1 |                |
|          |              | < CONNECTOR >                  |         |          | Q881     | 8-729-027-43   | TRANSISTOR RT1N141C-TP-1 |                |
| CN302    | 1-691-768-11 | PLUG (MICRO CONNECTOR) 6P      |         |          |          | < RESISTOR >   |                          |                |
| CN303    | 1-691-770-11 | PLUG (MICRO CONNECTOR) 8P      |         |          | R301     | 1-259-404-11   | CARBON 100 5% 1/6W       |                |
| CN304    | 1-691-766-11 | PLUG (MICRO CONNECTOR) 4P      |         |          | R304     | 1-259-380-11   | CARBON 10 5% 1/6W        |                |
| CN800    | 1-770-653-11 | CONNECTOR, FFC/FPC 25P         |         |          | R308     | 1-259-404-11   | CARBON 100 5% 1/6W       |                |
| CN801    | 1-568-440-11 | SOCKET, CONNECTOR 17P          |         |          | R309     | 1-216-025-91   | RES,CHIP 100 5% 1/10W    |                |
| CN803    | 1-770-651-11 | CONNECTOR, FFC/FPC 23P         |         |          | R310     | 1-259-404-11   | CARBON 100 5% 1/6W       |                |
| CN804    | 1-779-289-11 | CONNECTOR,FFC(LIF(NON-ZIF))21P |         |          | R311     | 1-249-504-11   | CARBON 10 5% 1/4W        |                |
| CN806    | 1-569-490-11 | SOCKET, CONNECTOR 3P           |         |          | R312     | 1-249-504-11   | CARBON 10 5% 1/4W        |                |
| * CN807  | 1-770-639-11 | CONNECTOR, FFC/FPC 8P          |         |          | R313     | 1-249-504-11   | CARBON 10 5% 1/4W        |                |
| * CN808  | 1-564-709-11 | PIN, CONNECTOR (SMALL TYPE) 7P |         |          | R314     | 1-249-504-11   | CARBON 10 5% 1/4W        |                |
| * CN809  | 1-564-705-11 | PIN, CONNECTOR (SMALL TYPE) 3P |         |          | R315     | 1-249-576-11   | CARBON 10K 5% 1/4W       |                |
|          |              | < DIODE >                      |         |          | R316     | 1-249-576-11   | CARBON 10K 5% 1/4W       |                |
| D301     | 8-719-911-19 | DIODE 1SS133T-72               |         |          | R317     | 1-249-576-11   | CARBON 10K 5% 1/4W       |                |
| D302     | 8-719-911-19 | DIODE 1SS133T-72               |         |          | R318     | 1-249-576-11   | CARBON 10K 5% 1/4W       |                |
| D303     | 8-719-911-19 | DIODE 1SS133T-72               |         |          | R319     | 1-249-576-11   | CARBON 10K 5% 1/4W       |                |
| D304     | 8-719-911-19 | DIODE 1SS133T-72               |         |          | R320     | 1-249-576-11   | CARBON 10K 5% 1/4W       |                |
| D305     | 8-719-911-19 | DIODE 1SS133T-72               |         |          | R321     | 1-249-588-91   | CARBON 33K 5% 1/4W       |                |
| D306     | 8-719-911-19 | DIODE 1SS133T-72               |         |          | R322     | 1-249-588-91   | CARBON 33K 5% 1/4W       |                |
| D307     | 8-719-911-19 | DIODE 1SS133T-72               |         |          | R323     | 1-249-941-11   | CARBON 5.6K 5% 1/4W      |                |
| D308     | 8-719-911-19 | DIODE 1SS133T-72               |         |          | R324     | 1-249-941-11   | CARBON 5.6K 5% 1/4W      |                |
| D309     | 8-719-210-39 | DIODE EC10QS-04-TE12L          |         |          | R325     | 1-249-469-11   | CARBON 100K 5% 1/4W      |                |
| D310     | 8-719-210-39 | DIODE EC10QS-04-TE12L          |         |          | R326     | 1-249-469-11   | CARBON 100K 5% 1/4W      |                |
| D802     | 8-719-911-19 | DIODE 1SS133T-72               |         |          | R327     | 1-249-923-11   | CARBON 1K 5% 1/4W        |                |
| D803     | 8-719-911-19 | DIODE 1SS133T-72               |         |          | R328     | 1-249-923-11   | CARBON 1K 5% 1/4W        |                |
| D805     | 8-719-210-21 | DIODE 11EQS04-TA2B             |         |          | R329     | 1-249-995-11   | CARBON 1M 5% 1/4W        |                |
| D806     | 8-719-200-82 | DIODE 11ES2-TA2B               |         |          | R330     | 1-249-995-11   | CARBON 1M 5% 1/4W        |                |
|          |              | < IC >                         |         |          | R331     | 1-249-995-11   | CARBON 1M 5% 1/4W        |                |
| IC301    | 8-759-280-17 | IC CXD8512Q                    |         |          | R332     | 1-249-995-11   | CARBON 1M 5% 1/4W        |                |
| IC302    | 8-759-330-53 | IC CXD8493M-E1                 |         |          | R800     | 1-216-073-00   | METAL CHIP 10K 5% 1/10W  |                |
| IC303    | 8-759-701-65 | IC M5F79M05L                   |         |          | R801     | 1-216-073-00   | METAL CHIP 10K 5% 1/10W  |                |
| IC304    | 8-759-604-35 | IC M5F78M05L                   |         |          | R802     | 1-216-073-00   | METAL CHIP 10K 5% 1/10W  |                |
| IC305    | 8-759-712-02 | IC NJM2114D                    |         |          | R803     | 1-216-073-00   | METAL CHIP 10K 5% 1/10W  |                |
| IC306    | 8-759-712-02 | IC NJM2114D                    |         |          | R804     | 1-216-073-00   | METAL CHIP 10K 5% 1/10W  |                |
| IC307    | 8-759-712-02 | IC NJM2114D                    |         |          | R806     | 1-216-097-91   | RES,CHIP 100K 5% 1/10W   |                |
| IC308    | 8-759-712-02 | IC NJM2114D                    |         |          | R807     | 1-216-097-91   | RES,CHIP 100K 5% 1/10W   |                |
| IC800    | 8-759-596-80 | IC M30624MG-215FP              |         |          | R808     | 1-216-073-00   | METAL CHIP 10K 5% 1/10W  |                |
| IC801    | 8-759-242-70 | IC TC7WU04F-TE12L              |         |          | R809     | 1-216-097-91   | RES,CHIP 100K 5% 1/10W   |                |
| IC802    | 8-759-572-68 | IC L88MS33T-MA                 |         |          | R810     | 1-216-097-91   | RES,CHIP 100K 5% 1/10W   |                |
| IC803    | 8-759-491-36 | IC TC74VHCT244AF(EL)           |         |          | R811     | 1-216-073-00   | METAL CHIP 10K 5% 1/10W  |                |
| IC804    | 8-759-174-16 | IC TC74VHC244F(EL)             |         |          | R812     | 1-216-073-00   | METAL CHIP 10K 5% 1/10W  |                |
| IC805    | 8-759-242-70 | IC TC7WU04F-TE12L              |         |          | R813     | 1-216-073-00   | METAL CHIP 10K 5% 1/10W  |                |
|          |              | < JUMPER RESISTOR >            |         |          | R814     | 1-216-073-00   | METAL CHIP 10K 5% 1/10W  |                |
| JR803    | 1-216-295-91 | SHORT 0                        |         |          | R815     | 1-216-073-00   | METAL CHIP 10K 5% 1/10W  |                |
| JR804    | 1-216-295-91 | SHORT 0                        |         |          | R816     | 1-216-073-00   | METAL CHIP 10K 5% 1/10W  |                |
|          |              |                                |         |          | R819     | 1-216-109-00   | METAL CHIP 330K 5% 1/10W |                |
|          |              |                                |         |          | R820     | 1-216-073-00   | METAL CHIP 10K 5% 1/10W  |                |

| Ref. No. | Part No.     | Description                 | Remarks |     |
|----------|--------------|-----------------------------|---------|-----|
| R822     | 1-216-073-00 | METAL CHIP 10K 5%           | 1/10W   |     |
| R823     | 1-216-097-91 | RES,CHIP 100K 5%            | 1/10W   |     |
| R824     | 1-216-097-91 | RES,CHIP 100K 5%            | 1/10W   |     |
| R826     | 1-216-073-00 | METAL CHIP 10K 5%           | 1/10W   |     |
| R827     | 1-216-073-00 | METAL CHIP 10K 5%           | 1/10W   |     |
| R829     | 1-216-073-00 | METAL CHIP 10K 5%           | 1/10W   |     |
| R830     | 1-216-073-00 | METAL CHIP 10K 5%           | 1/10W   |     |
| R832     | 1-216-073-00 | METAL CHIP 10K 5%           | 1/10W   |     |
| R833     | 1-216-073-00 | METAL CHIP 10K 5%           | 1/10W   |     |
| R834     | 1-216-025-91 | RES,CHIP 100 5%             | 1/10W   |     |
| R835     | 1-216-025-91 | RES,CHIP 100 5%             | 1/10W   |     |
| R836     | 1-216-073-00 | METAL CHIP 10K 5%           | 1/10W   |     |
| R837     | 1-216-073-00 | METAL CHIP 10K 5%           | 1/10W   |     |
| R838     | 1-216-091-00 | METAL CHIP 56K 5%           | 1/10W   |     |
| R839     | 1-216-049-91 | RES,CHIP 1K 5%              | 1/10W   |     |
| R840     | 1-216-073-00 | METAL CHIP 10K 5%           | 1/10W   |     |
| R841     | 1-216-073-00 | METAL CHIP 10K 5%           | 1/10W   |     |
| R842     | 1-216-073-00 | METAL CHIP 10K 5%           | 1/10W   |     |
| R843     | 1-216-073-00 | METAL CHIP 10K 5%           | 1/10W   |     |
| R844     | 1-216-073-00 | METAL CHIP 10K 5%           | 1/10W   |     |
| R845     | 1-216-073-00 | METAL CHIP 10K 5%           | 1/10W   |     |
| R846     | 1-216-073-00 | METAL CHIP 10K 5%           | 1/10W   |     |
| R847     | 1-216-073-00 | METAL CHIP 10K 5%           | 1/10W   |     |
| R848     | 1-216-073-00 | METAL CHIP 10K 5%           | 1/10W   |     |
| R851     | 1-214-917-00 | METAL CHIP 10K 1%           | 0.60W   |     |
| R854     | 1-216-073-00 | METAL CHIP 10K 5%           | 1/10W   |     |
| R855     | 1-216-073-00 | METAL CHIP 10K 5%           | 1/10W   |     |
| R856     | 1-216-025-91 | RES,CHIP 100 5%             | 1/10W   |     |
| R857     | 1-216-025-91 | RES,CHIP 100 5%             | 1/10W   |     |
| R858     | 1-216-025-91 | RES,CHIP 100 5%             | 1/10W   |     |
| R863     | 1-216-025-91 | RES,CHIP 100 5%             | 1/10W   |     |
| R864     | 1-216-097-91 | RES,CHIP 100K 5%            | 1/10W   |     |
| R874     | 1-216-025-91 | RES,CHIP 100 5%             | 1/10W   |     |
| R876     | 1-216-025-91 | RES,CHIP 100 5%             | 1/10W   |     |
| R877     | 1-259-404-11 | CARBON 100 5%               | 1/6W    |     |
| R878     | 1-216-025-91 | RES,CHIP 100 5%             | 1/10W   |     |
| R880     | 1-216-073-00 | METAL CHIP 10K 5%           | 1/10W   |     |
| R881     | 1-216-073-00 | METAL CHIP 10K 5%           | 1/10W   |     |
| R882     | 1-259-404-11 | CARBON 100 5%               | 1/6W    |     |
| R883     | 1-259-404-11 | CARBON 100 5%               | 1/6W    |     |
| R884     | 1-259-404-11 | CARBON 100 5%               | 1/6W    |     |
|          |              | < VIBRATOR >                |         |     |
| X800     | 1-767-778-21 | VIBRATOR, CERAMIC 7MHZ      |         |     |
| X801     | 1-567-098-41 | VIBRATOR, CRYSTAL 32.768KHZ |         |     |
| *****    |              |                             |         |     |
| *        | A-4724-285-A | BD BOARD, COMPLETE          |         |     |
|          |              | *****                       |         |     |
|          |              | < CAPACITOR >               |         |     |
| C101     | 1-125-822-11 | TANTALUM 10uF 20%           | 10V     |     |
| C102     | 1-163-038-91 | CERAMIC CHIP 0.1uF          | 25V     |     |
| C103     | 1-125-822-11 | TANTALUM 10uF 20%           | 10V     |     |
| C104     | 1-125-822-11 | TANTALUM 10uF 20%           | 10V     |     |
| C105     | 1-163-021-91 | CERAMIC CHIP 0.01uF         | 50V     |     |
| C106     | 1-163-275-11 | CERAMIC CHIP 0.001uF        | 5%      | 50V |
| C107     | 1-163-038-91 | CERAMIC CHIP 0.1uF          | 25V     |     |
| C108     | 1-163-038-91 | CERAMIC CHIP 0.1uF          | 25V     |     |
| C109     | 1-163-037-11 | CERAMIC CHIP 0.022uF        | 10%     | 25V |
| C111     | 1-164-344-11 | CERAMIC CHIP 0.068uF        | 10%     | 25V |

| Ref. No. | Part No.     | Description                    | Remarks |     |
|----------|--------------|--------------------------------|---------|-----|
| C112     | 1-163-017-00 | CERAMIC CHIP 0.0047uF 5%       | 50V     |     |
| C113     | 1-109-982-11 | CERAMIC CHIP 1uF 10%           | 10V     |     |
| C115     | 1-164-489-11 | CERAMIC CHIP 0.22uF 10%        | 16V     |     |
| C116     | 1-163-037-11 | CERAMIC CHIP 0.022uF 10%       | 25V     |     |
| C117     | 1-163-809-11 | CERAMIC CHIP 0.047uF 10%       | 25V     |     |
| C118     | 1-163-038-91 | CERAMIC CHIP 0.1uF             | 25V     |     |
| C119     | 1-125-822-11 | TANTALUM 10uF 20%              | 10V     |     |
| C121     | 1-125-822-11 | TANTALUM 10uF 20%              | 10V     |     |
| C122     | 1-163-021-91 | CERAMIC CHIP 0.01uF 10%        | 50V     |     |
| C123     | 1-163-038-91 | CERAMIC CHIP 0.1uF             | 25V     |     |
| C124     | 1-163-038-91 | CERAMIC CHIP 0.1uF             | 25V     |     |
| C127     | 1-163-038-91 | CERAMIC CHIP 0.1uF             | 25V     |     |
| C128     | 1-163-021-91 | CERAMIC CHIP 0.01uF            | 10%     | 50V |
| C129     | 1-107-823-11 | CERAMIC CHIP 0.47uF            | 10%     | 16V |
| C130     | 1-163-251-11 | CERAMIC CHIP 100PF 5%          | 50V     |     |
| C131     | 1-163-023-00 | CERAMIC CHIP 0.015uF 5%        | 50V     |     |
| C132     | 1-107-823-11 | CERAMIC CHIP 0.47uF 10%        | 16V     |     |
| C133     | 1-163-017-00 | CERAMIC CHIP 0.0047uF 5%       | 50V     |     |
| C134     | 1-163-038-91 | CERAMIC CHIP 0.1uF             | 25V     |     |
| C135     | 1-163-038-91 | CERAMIC CHIP 0.1uF             | 25V     |     |
| C136     | 1-126-206-11 | ELECT CHIP 100uF 20%           | 6.3V    |     |
| C142     | 1-163-251-11 | CERAMIC CHIP 100PF 5%          | 50V     |     |
| C143     | 1-163-251-11 | CERAMIC CHIP 100PF 5%          | 50V     |     |
| C144     | 1-163-251-11 | CERAMIC CHIP 100PF 5%          | 50V     |     |
| C146     | 1-163-038-91 | CERAMIC CHIP 0.1uF             | 25V     |     |
| C151     | 1-126-206-11 | ELECT CHIP 100uF 20%           | 6.3V    |     |
| C152     | 1-163-038-91 | CERAMIC CHIP 0.1uF             | 25V     |     |
| C153     | 1-163-021-91 | CERAMIC CHIP 0.01uF            | 10%     | 50V |
| C156     | 1-163-038-91 | CERAMIC CHIP 0.1uF             | 25V     |     |
| C158     | 1-163-019-00 | CERAMIC CHIP 0.0068uF 10%      | 50V     |     |
| C160     | 1-104-601-11 | ELECT CHIP 10uF 20%            | 10V     |     |
| C161     | 1-104-601-11 | ELECT CHIP 10uF 20%            | 10V     |     |
| C163     | 1-163-021-91 | CERAMIC CHIP 0.01uF            | 10%     | 50V |
| C164     | 1-163-021-91 | CERAMIC CHIP 0.01uF            | 10%     | 50V |
| C167     | 1-163-038-91 | CERAMIC CHIP 0.1uF             | 25V     |     |
| C168     | 1-163-038-91 | CERAMIC CHIP 0.1uF             | 25V     |     |
| C169     | 1-125-822-11 | TANTALUM 10uF 20%              | 10V     |     |
| C171     | 1-163-038-91 | CERAMIC CHIP 0.1uF             | 25V     |     |
| C181     | 1-104-913-11 | TANTAL. CHIP 10uF 20%          | 16V     |     |
| C183     | 1-163-038-91 | CERAMIC CHIP 0.1uF             | 25V     |     |
| C184     | 1-117-970-11 | ELECT CHIP 22uF 20%            | 10V     |     |
| C185     | 1-164-611-11 | CERAMIC CHIP 0.001uF 10%       | 500V    |     |
| C187     | 1-104-913-11 | TANTAL. CHIP 10uF 20%          | 16V     |     |
| C188     | 1-163-021-91 | CERAMIC CHIP 0.01uF 10%        | 50V     |     |
| C189     | 1-163-989-11 | CERAMIC CHIP 0.033uF 10%       | 25V     |     |
| C190     | 1-126-206-11 | ELECT CHIP 100uF 20%           | 6.3V    |     |
| C191     | 1-163-038-91 | CERAMIC CHIP 0.1uF             | 25V     |     |
| C196     | 1-163-038-91 | CERAMIC CHIP 0.1uF             | 25V     |     |
| C197     | 1-163-038-91 | CERAMIC CHIP 0.1uF             | 25V     |     |
|          |              | < CONNECTOR >                  |         |     |
| CN101    | 1-569-479-21 | CONNECTOR, FPC 21P             |         |     |
| CN102    | 1-784-835-21 | CONNECTOR,FFC(LIF(NON-ZIF))27P |         |     |
| CN103    | 1-784-834-21 | CONNECTOR,FFC(LIF(NON-ZIF))23P |         |     |
| CN104    | 1-770-687-11 | CONNECTOR, FFC/FPC 4P          |         |     |
| CN110    | 1-695-440-21 | PIN, CONNECTOR (PC BOARD) 6P   |         |     |
|          |              | < DIODE >                      |         |     |
| D101     | 8-719-988-61 | DIODE 1SS355TE-17              |         |     |
| D181     | 8-719-046-86 | DIODE F1J6TP                   |         |     |
| D183     | 8-719-046-86 | DIODE F1J6TP                   |         |     |

| Ref. No. | Part No.     | Description                 | Remarks  | Ref. No. | Part No.     | Description     | Remarks  |
|----------|--------------|-----------------------------|----------|----------|--------------|-----------------|----------|
|          |              | < IC >                      |          |          |              |                 |          |
| IC101    | 8-752-080-95 | IC CXA2523AR                |          | R115     | 1-216-049-91 | RES,CHIP 1K     | 5% 1/10W |
| IC103    | 8-729-903-10 | TRANSISTOR FMW1-T-148       |          | R117     | 1-216-113-00 | METAL CHIP 470K | 5% 1/10W |
| IC121    | 8-752-390-16 | IC CXD2656R                 |          | R120     | 1-216-025-91 | RES,CHIP 100    | 5% 1/10W |
| IC123    | 8-759-096-87 | IC TC7WU04FU(TE12R)         |          | R121     | 1-216-097-91 | RES,CHIP 100K   | 5% 1/10W |
| IC124    | 8-759-498-44 | IC MSM51V4400-70TS-K        |          | R123     | 1-216-295-91 | SHORT 0         |          |
| IC124    | 8-759-334-38 | IC MN41V4400TT-08           |          | R124     | 1-216-025-91 | RES,CHIP 100    | 5% 1/10W |
| IC152    | 8-759-430-25 | IC BH6511FS-E2              |          | R125     | 1-216-295-91 | SHORT 0         |          |
| IC171    | 8-759-487-04 | IC BR24C02F-E2              |          | R127     | 1-216-025-91 | RES,CHIP 100    | 5% 1/10W |
| IC181    | 8-759-481-17 | IC MC74ACT08DTR2            |          | R129     | 1-216-295-91 | SHORT 0         |          |
| IC192    | 8-759-460-72 | IC BA033FP-E2               |          | R130     | 1-216-295-91 | SHORT 0         |          |
|          |              | < COIL >                    |          |          |              |                 |          |
| L101     | 1-414-813-11 | FERRITE 0uH                 |          | R131     | 1-216-073-00 | METAL CHIP 10K  | 5% 1/10W |
| L102     | 1-414-813-11 | FERRITE 0uH                 |          | R132     | 1-216-097-91 | RES,CHIP 100K   | 5% 1/10W |
| L103     | 1-414-813-11 | FERRITE 0uH                 |          | R133     | 1-216-117-00 | METAL CHIP 680K | 5% 1/10W |
| L105     | 1-414-813-11 | FERRITE 0uH                 |          | R134     | 1-216-049-91 | RES,CHIP 1K     | 5% 1/10W |
| L106     | 1-414-813-11 | FERRITE 0uH                 |          | R135     | 1-216-061-00 | METAL CHIP 3.3K | 5% 1/10W |
| L121     | 1-414-813-11 | FERRITE 0uH                 |          | R136     | 1-216-049-91 | RES,CHIP 1K     | 5% 1/10W |
| L122     | 1-414-813-11 | FERRITE 0uH                 |          | R137     | 1-216-295-91 | SHORT 0         |          |
| L151     | 1-412-029-11 | INDUCTOR CHIP 10uH          |          | R140     | 1-216-029-00 | METAL CHIP 150  | 5% 1/10W |
| L152     | 1-412-029-11 | INDUCTOR CHIP 10uH          |          | R142     | 1-216-073-00 | METAL CHIP 10K  | 5% 1/10W |
| L153     | 1-412-032-11 | INDUCTOR CHIP 100uH         |          | R143     | 1-216-073-00 | METAL CHIP 10K  | 5% 1/10W |
| L154     | 1-412-032-11 | INDUCTOR CHIP 100uH         |          | R144     | 1-216-295-91 | SHORT 0         |          |
| L161     | 1-414-813-11 | FERRITE 0uH                 |          | R145     | 1-216-073-00 | METAL CHIP 10K  | 5% 1/10W |
| L162     | 1-414-813-11 | FERRITE 0uH                 |          | R146     | 1-216-037-00 | METAL CHIP 330  | 5% 1/10W |
| L181     | 1-216-295-91 | SHORT 0                     |          | R147     | 1-216-025-91 | RES,CHIP 100    | 5% 1/10W |
|          |              | < TRANSISTOR >              |          | R148     | 1-216-045-00 | METAL CHIP 680  | 5% 1/10W |
| Q101     | 8-729-403-35 | TRANSISTOR RN2304-TE85L     |          | R149     | 1-216-073-00 | METAL CHIP 10K  | 5% 1/10W |
| Q101     | 8-729-028-91 | TRANSISTOR RT1P441M-TP-1    |          | R150     | 1-216-295-91 | SHORT 0         |          |
| Q101     | 8-729-403-35 | TRANSISTOR UN5113-TX        |          | R151     | 1-216-073-00 | METAL CHIP 10K  | 5% 1/10W |
| Q101     | 8-729-905-12 | TRANSISTOR DTA144EUT106     |          | R152     | 1-216-073-00 | METAL CHIP 10K  | 5% 1/10W |
| Q102     | 8-729-026-53 | TRANSISTOR 2SA1576A-T106-QR |          | R158     | 1-216-097-91 | RES,CHIP 100K   | 5% 1/10W |
| Q103     | 8-729-028-99 | TRANSISTOR RN1307-TE85L     |          | R159     | 1-216-097-91 | RES,CHIP 100K   | 5% 1/10W |
| Q103     | 8-729-028-99 | TRANSISTOR RT1N144M-TP-1    |          | R160     | 1-216-295-91 | SHORT 0         |          |
| Q103     | 8-729-402-93 | TRANSISTOR UN5214-TX        |          | R161     | 1-216-057-00 | METAL CHIP 2.2K | 5% 1/10W |
| Q103     | 8-729-028-99 | TRANSISTOR DTC114YUT106     |          | R162     | 1-216-057-00 | METAL CHIP 2.2K | 5% 1/10W |
| Q104     | 8-729-028-99 | TRANSISTOR RN1307-TE85L     |          | R163     | 1-216-057-00 | METAL CHIP 2.2K | 5% 1/10W |
| Q104     | 8-729-028-99 | TRANSISTOR RT1N144M-TP-1    |          | R164     | 1-216-045-00 | METAL CHIP 680  | 5% 1/10W |
| Q104     | 8-729-402-93 | TRANSISTOR UN5214-TX        |          | R165     | 1-216-097-91 | RES,CHIP 100K   | 5% 1/10W |
| Q104     | 8-729-028-99 | TRANSISTOR DTC114YUT106     |          | R167     | 1-216-065-91 | RES,CHIP 4.7K   | 5% 1/10W |
| Q162     | 8-729-101-07 | TRANSISTOR 2SB798-T1DK      |          | R169     | 1-219-724-11 | METAL CHIP 1    | 1% 1/4W  |
| Q163     | 8-729-403-35 | TRANSISTOR RN2304-TE85L     |          | R170     | 1-216-073-00 | METAL CHIP 10K  | 5% 1/10W |
| Q163     | 8-729-028-91 | TRANSISTOR RT1P441M-TP-1    |          | R171     | 1-216-073-00 | METAL CHIP 10K  | 5% 1/10W |
| Q163     | 8-729-403-35 | TRANSISTOR UN5113-TX        |          | R173     | 1-216-121-91 | RES,CHIP 1M     | 5% 1/10W |
| Q163     | 8-729-905-12 | TRANSISTOR DTA144EUT106     |          | R175     | 1-216-065-91 | RES,CHIP 4.7K   | 5% 1/10W |
| Q181     | 8-729-018-75 | TRANSISTOR 2SJ278MYTR       |          | R177     | 1-216-061-00 | METAL CHIP 3.3K | 5% 1/10W |
| Q182     | 8-729-017-65 | TRANSISTOR 2SK1764KYTR      |          | R179     | 1-216-085-00 | METAL CHIP 33K  | 5% 1/10W |
|          |              | < RESISTOR >                |          |          |              |                 |          |
| R103     | 1-216-049-91 | RES,CHIP 1K                 | 5% 1/10W | R186     | 1-216-089-91 | RES,CHIP 47K    | 5% 1/10W |
| R104     | 1-216-073-00 | METAL CHIP 10K              | 5% 1/10W | R188     | 1-216-073-00 | METAL CHIP 10K  | 5% 1/10W |
| R105     | 1-216-065-91 | RES,CHIP 4.7K               | 5% 1/10W | R189     | 1-216-073-00 | METAL CHIP 10K  | 5% 1/10W |
| R106     | 1-216-133-00 | METAL CHIP 3.3M             | 5% 1/10W | R190     | 1-216-073-00 | METAL CHIP 10K  | 5% 1/10W |
| R107     | 1-216-113-00 | METAL CHIP 470K             | 5% 1/10W | R195     | 1-216-073-00 | METAL CHIP 10K  | 5% 1/10W |
| R109     | 1-216-295-91 | SHORT 0                     |          | R196     | 1-216-295-91 | SHORT 0         |          |
| R110     | 1-216-073-00 | METAL CHIP 10K              | 5% 1/10W | R197     | 1-216-295-91 | SHORT 0         |          |
| R111     | 1-216-295-91 | SHORT 0                     |          | R198     | 1-216-286-00 | RES,CHIP 4.7M   | 5% 1/8W  |
| R112     | 1-216-089-91 | RES,CHIP 47K                | 5% 1/10W | R198     | 1-216-296-91 | SHORT 0         |          |
| R113     | 1-216-049-91 | RES,CHIP 1K                 | 5% 1/10W |          |              |                 |          |



| Ref. No. | Part No.     | Description                    | Remarks         | Ref. No. | Part No.     | Description  | Remarks          |
|----------|--------------|--------------------------------|-----------------|----------|--------------|--------------|------------------|
|          |              | < SWITCH >                     |                 | C528     | 1-128-198-11 | ELECT        | 22uF 20% 63V     |
| S101     | 1-762-596-21 | SWITCH, PUSH (1 KEY)(LIMIT IN) |                 | C530     | 1-164-159-11 | CERAMIC      | 0.1uF 50V        |
| *****    |              |                                |                 | C531     | 1-136-960-11 | FILM         | 0.1uF 10% 160V   |
|          | 1-674-325-11 | BT BOARD                       |                 | C532     | 1-164-159-11 | CERAMIC      | 0.1uF 50V        |
|          |              | *****                          |                 | C535     | 1-164-159-11 | CERAMIC      | 0.1uF 50V        |
|          |              | < BATTERY >                    |                 | C537     | 1-126-052-11 | ELECT        | 100uF 20% 16V    |
| BT701    | 1-528-887-11 | BATTERY, LITHIUM SECONDARY     |                 | C541     | 1-126-052-11 | ELECT        | 100uF 20% 16V    |
|          |              | < CONNECTOR >                  |                 | C543     | 1-164-159-11 | CERAMIC      | 0.1uF 50V        |
| * CN703  | 1-569-499-11 | PIN, CONNECTOR 3P              |                 | C544     | 1-136-165-00 | FILM         | 0.1uF 5% 50V     |
| *****    |              |                                |                 | C545     | 1-136-165-00 | FILM         | 0.1uF 5% 50V     |
|          | A-4724-801-A | DA BOARD, COMPLETE(AEP,UK)     |                 | C547     | 1-124-724-11 | ELECT        | 47uF 20% 50V     |
|          |              | *****                          |                 | C548     | 1-124-724-11 | ELECT        | 47uF 20% 50V     |
|          | A-4724-802-A | DA BOARD, COMPLETE(US,CND)     |                 | C549     | 1-136-165-00 | FILM         | 0.1uF 5% 50V     |
|          |              | *****                          |                 | C550     | 1-136-165-00 | FILM         | 0.1uF 5% 50V     |
|          |              | < BUS BAR >                    |                 | C551     | 1-126-052-11 | ELECT        | 100uF 20% 16V    |
| * BB501  | 1-560-242-31 | BUS BAR 5P                     |                 | C553     | 1-126-052-11 | ELECT        | 100uF 20% 16V    |
|          |              | < CAPACITOR >                  |                 | C554     | 1-164-159-11 | CERAMIC      | 0.1uF 50V        |
| C430     | 1-124-699-11 | ELECT                          | 220uF 20% 10V   | C555     | 1-164-159-11 | CERAMIC      | 0.1uF 50V        |
| C431     | 1-164-159-11 | CERAMIC                        | 0.1uF 50V       | C556     | 1-136-820-11 | FILM         | 0.01uF 5% 100V   |
| C432     | 1-164-159-11 | CERAMIC                        | 0.1uF 50V       | C557     | 1-136-820-11 | FILM         | 0.01uF 5% 100V   |
| C433     | 1-124-724-11 | ELECT                          | 47uF 20% 50V    | C558     | 1-126-103-11 | ELECT        | 470uF 20% 16V    |
| C434     | 1-124-699-11 | ELECT                          | 220uF 20% 10V   | C559     | 1-126-103-11 | ELECT        | 470uF 20% 16V    |
| C435     | 1-164-159-11 | CERAMIC                        | 0.1uF 50V       | C560     | 1-164-159-11 | CERAMIC      | 0.1uF 50V        |
| C436     | 1-164-159-11 | CERAMIC                        | 0.1uF 50V       | C561     | 1-164-159-11 | CERAMIC      | 0.1uF 50V        |
| C437     | 1-124-724-11 | ELECT                          | 47uF 20% 50V    | C562     | 1-130-849-00 | FILM         | 0.039uF 3% 100V  |
| C442     | 1-164-159-11 | CERAMIC                        | 0.1uF 50V       | C563     | 1-130-849-00 | FILM         | 0.039uF 3% 100V  |
| C443     | 1-164-159-11 | CERAMIC                        | 0.1uF 50V       | C564     | 1-130-849-00 | FILM         | 0.039uF 3% 100V  |
| C501     | 1-124-995-11 | ELECT                          | 220uF 20% 10V   | C565     | 1-130-849-00 | FILM         | 0.039uF 3% 100V  |
| C502     | 1-162-294-31 | CERAMIC                        | 0.001uF 10% 50V | C566     | 1-136-233-11 | FILM         | 0.0047uF 3% 100V |
| C503     | 1-164-159-11 | CERAMIC                        | 0.1uF 50V       | C567     | 1-136-233-11 | FILM         | 0.0047uF 3% 100V |
| C504     | 1-124-995-11 | ELECT                          | 220uF 20% 10V   | C568     | 1-136-233-11 | FILM         | 0.0047uF 3% 100V |
| C505     | 1-164-159-11 | CERAMIC                        | 0.1uF 50V       | C569     | 1-136-233-11 | FILM         | 0.0047uF 3% 100V |
| C506     | 1-124-995-11 | ELECT                          | 220uF 20% 10V   | C570     | 1-136-356-11 | FILM         | 470PF 5% 100V    |
| C507     | 1-164-159-11 | CERAMIC                        | 0.1uF 50V       | C571     | 1-136-356-11 | FILM         | 470PF 5% 100V    |
| C508     | 1-164-159-11 | CERAMIC                        | 0.1uF 50V       | C572     | 1-136-356-11 | FILM         | 470PF 5% 100V    |
| C509     | 1-164-159-11 | CERAMIC                        | 0.1uF 50V       | C573     | 1-136-356-11 | FILM         | 470PF 5% 100V    |
| C510     | 1-164-159-11 | CERAMIC                        | 0.1uF 50V       | C574     | 1-163-251-11 | CERAMIC CHIP | 100PF 5% 50V     |
| C513     | 1-124-699-11 | ELECT                          | 220uF 20% 10V   | C575     | 1-163-251-11 | CERAMIC CHIP | 100PF 5% 50V     |
| C514     | 1-164-159-11 | CERAMIC                        | 0.1uF 50V       | C576     | 1-136-818-11 | FILM         | 0.0047uF 5% 100V |
| C515     | 1-164-159-11 | CERAMIC                        | 0.1uF 50V       | C577     | 1-136-818-11 | FILM         | 0.0047uF 5% 100V |
| C516     | 1-124-699-11 | ELECT                          | 220uF 20% 10V   | C578     | 1-163-251-11 | CERAMIC CHIP | 100PF 5% 50V     |
| C517     | 1-164-159-11 | CERAMIC                        | 0.1uF 50V       | C580     | 1-136-814-11 | FILM         | 0.001uF 5% 100V  |
| C518     | 1-164-159-11 | CERAMIC                        | 0.1uF 50V       | C581     | 1-136-814-11 | FILM         | 0.001uF 5% 100V  |
| C519     | 1-162-199-31 | CERAMIC                        | 10PF 5% 50V     | C588     | 1-128-554-11 | ELECT        | 330uF 20% 50V    |
| C520     | 1-162-199-31 | CERAMIC                        | 10PF 5% 50V     | C589     | 1-128-554-11 | ELECT        | 330uF 20% 50V    |
| C521     | 1-124-699-11 | ELECT                          | 220uF 20% 10V   | C590     | 1-162-294-31 | CERAMIC      | 0.001uF 10% 50V  |
| C522     | 1-124-699-11 | ELECT                          | 220uF 20% 10V   | C593     | 1-162-294-31 | CERAMIC      | 0.001uF 10% 50V  |
| C523     | 1-164-159-11 | CERAMIC                        | 0.1uF 50V       | C594     | 1-164-732-11 | CERAMIC      | 0.1uF 20% 50V    |
| C524     | 1-124-699-11 | ELECT                          | 220uF 20% 10V   | C601     | 1-136-259-11 | FILM         | 0.1uF 3% 100V    |
| C525     | 1-124-689-11 | ELECT                          | 1000uF 20% 16V  | C602     | 1-136-259-11 | FILM         | 0.1uF 3% 100V    |
| C526     | 1-128-198-11 | ELECT                          | 22uF 20% 63V    | C603     | 1-104-646-11 | CERAMIC      | 2.2uF 20% 50V    |
| C527     | 1-136-960-11 | FILM                           | 0.1uF 10% 160V  | C604     | 1-104-646-11 | CERAMIC      | 2.2uF 20% 50V    |
|          |              |                                |                 | C605     | 1-136-960-11 | FILM         | 0.1uF 10% 160V   |
|          |              |                                |                 | C606     | 1-136-960-11 | FILM         | 0.1uF 10% 160V   |
|          |              |                                |                 | C610     | 1-163-217-11 | CERAMIC CHIP | 1PF 0.25PF 50V   |
|          |              |                                |                 | C611     | 1-163-217-11 | CERAMIC CHIP | 1PF 0.25PF 50V   |
|          |              |                                |                 | C612     | 1-163-038-91 | CERAMIC CHIP | 0.1MF 25V        |
|          |              |                                |                 | C613     | 1-163-217-11 | CERAMIC CHIP | 1PF 0.25PF 50V   |
|          |              |                                |                 | C614     | 1-163-038-91 | CERAMIC CHIP | 0.1MF 25V        |
|          |              |                                |                 | C615     | 1-162-187-31 | CERAMIC CHIP | 0.1MF 25V        |

| Ref. No. | Part No.     | Description                    | Remarks | Ref. No. | Part No.     | Description       | Remarks |
|----------|--------------|--------------------------------|---------|----------|--------------|-------------------|---------|
|          |              | < CONNECTOR >                  |         |          |              | < RESISTOR >      |         |
| CN501    | 1-568-440-11 | SOCKET, CONNECTOR 17P          |         | R501     | 1-259-380-11 | CARBON 10 5%      | 1/6W    |
| CN502    | 1-770-655-11 | CONNECTOR, FFC/FPC 27P         |         | R502     | 1-259-380-11 | CARBON 10 5%      | 1/6W    |
| CN503    | 1-793-565-11 | CONNECTOR (FFC) 13P            |         | R503     | 1-259-380-11 | CARBON 10 5%      | 1/6W    |
| * CN504  | 1-564-709-11 | PIN, CONNECTOR (SMALL TYPE) 7P |         | R504     | 1-259-380-11 | CARBON 10 5%      | 1/6W    |
| * CN506  | 1-564-706-11 | PIN, CONNECTOR (SMALL TYPE) 4P |         | R505     | 1-259-404-11 | CARBON 100 5%     | 1/6W    |
| CN507    | 1-691-773-11 | PLUG (MICRO CONNECTOR) 11P     |         | R506     | 1-259-404-11 | CARBON 100 5%     | 1/6W    |
|          |              | < DIODE >                      |         | R507     | 1-259-404-11 | CARBON 100 5%     | 1/6W    |
| D501     | 8-719-210-21 | DIODE 11EQS04-TA2B             |         | R508     | 1-259-404-11 | CARBON 100 5%     | 1/6W    |
| D502     | 8-719-210-21 | DIODE 11EQS04-TA2B             |         | R510     | 1-259-380-11 | CARBON 10 5%      | 1/6W    |
| D503     | 8-719-911-19 | DIODE 1SS133T-72               |         | R511     | 1-259-380-11 | CARBON 10 5%      | 1/6W    |
| D505     | 8-719-210-21 | DIODE 11EQS04-TA2B             |         | R512     | 1-259-380-11 | CARBON 10 5%      | 1/6W    |
| D507     | 8-719-911-19 | DIODE 1SS133T-72               |         | R513     | 1-216-025-91 | RES,CHIP 100 5%   | 1/10W   |
| D508     | 8-719-911-19 | DIODE 1SS133T-72               |         | R514     | 1-259-404-11 | CARBON 100 5%     | 1/6W    |
|          |              | < TERMINAL >                   |         | R517     | 1-259-412-11 | CARBON 220 5%     | 1/6W    |
| ET501    | 4-924-264-01 | TERMINAL, MOUNT                |         | R518     | 1-216-025-91 | RES,CHIP 100 5%   | 1/10W   |
|          |              | < IC >                         |         | R519     | 1-259-404-11 | CARBON 100 5%     | 1/6W    |
| IC501    | 8-759-573-17 | IC CXD8762Q                    |         | R520     | 1-259-452-11 | CARBON 10K 5%     | 1/6W    |
| IC501    | 8-759-573-17 | IC CXD8762AQ                   |         | R521     | 1-259-416-11 | CARBON 330 5%     | 1/6W    |
| IC502    | 8-759-596-81 | IC CXD9521Q                    |         | R522     | 1-259-416-11 | CARBON 330 5%     | 1/6W    |
| IC503    | 8-759-604-35 | IC M5F78M05L                   |         | R523     | 1-259-416-11 | CARBON 330 5%     | 1/6W    |
| IC504    | 8-759-371-51 | IC CXA8042AS                   |         | R524     | 1-259-416-11 | CARBON 330 5%     | 1/6W    |
| IC505    | 8-759-371-51 | IC CXA8042AS                   |         | R525     | 1-259-416-11 | CARBON 330 5%     | 1/6W    |
| IC506    | 8-759-604-95 | IC M5F79M07L                   |         | R526     | 1-259-416-11 | CARBON 330 5%     | 1/6W    |
| IC507    | 8-759-605-00 | IC M5F78M07L                   |         | R527     | 1-259-416-11 | CARBON 330 5%     | 1/6W    |
| IC508    | 8-759-259-12 | IC OPA2604AP                   |         | R528     | 1-259-416-11 | CARBON 330 5%     | 1/6W    |
| IC509    | 8-759-259-12 | IC OPA2604AP                   |         | R529     | 1-259-416-11 | CARBON 330 5%     | 1/6W    |
| IC510    | 8-759-443-33 | IC OPA2132PA                   |         | R530     | 1-259-416-11 | CARBON 330 5%     | 1/6W    |
| IC511    | 8-759-443-33 | IC OPA2132PA                   |         | R531     | 1-249-504-11 | CARBON 10 5%      | 1/4W    |
| IC512    | 8-759-081-44 | IC TC74VHC04F(EL)              |         | R532     | 1-249-504-11 | CARBON 10 5%      | 1/4W    |
| IC513    | 8-759-053-07 | IC OP-27GP                     |         | R533     | 1-249-504-11 | CARBON 10 5%      | 1/4W    |
| IC514    | 8-759-242-70 | IC TC7WU04F-TE12L              |         | R534     | 1-249-504-11 | CARBON 10 5%      | 1/4W    |
| IC515    | 8-759-053-07 | IC OP-27GP                     |         | R535     | 1-249-504-11 | CARBON 10 5%      | 1/4W    |
|          |              | < COIL >                       |         | R536     | 1-249-504-11 | CARBON 10 5%      | 1/4W    |
| L501     | 1-408-599-31 | INDUCTOR 4.7uH                 |         | R537     | 1-249-504-11 | CARBON 10 5%      | 1/4W    |
| L502     | 1-408-599-31 | INDUCTOR 4.7uH                 |         | R538     | 1-249-504-11 | CARBON 10 5%      | 1/4W    |
| * L503   | 1-410-858-21 | INDUCTOR 0uH                   |         | R539     | 1-249-885-11 | CARBON 27 5%      | 1/4W    |
| L504     | 1-408-599-31 | INDUCTOR 4.7uH                 |         | R540     | 1-249-885-11 | CARBON 27 5%      | 1/4W    |
| L505     | 1-408-599-31 | INDUCTOR 4.7uH                 |         | R541     | 1-249-885-11 | CARBON 27 5%      | 1/4W    |
| L506     | 1-408-599-31 | INDUCTOR 4.7uH                 |         | R542     | 1-249-885-11 | CARBON 27 5%      | 1/4W    |
| L507     | 1-408-599-31 | INDUCTOR 4.7uH                 |         | R543     | 1-249-542-11 | CARBON 390 5%     | 1/4W    |
| L508     | 1-408-599-31 | INDUCTOR 4.7uH                 |         | R544     | 1-249-542-11 | CARBON 390 5%     | 1/4W    |
| L509     | 1-408-599-31 | INDUCTOR 4.7uH                 |         | R545     | 1-249-542-11 | CARBON 390 5%     | 1/4W    |
| L510     | 1-414-235-22 | INDUCTOR CHIP 0UH              |         | R546     | 1-249-542-11 | CARBON 390 5%     | 1/4W    |
| L511     | 1-414-235-22 | INDUCTOR CHIP 0UH              |         | R547     | 1-249-941-11 | CARBON 5.6K 5%    | 1/4W    |
| L513     | 1-412-776-11 | INDUCTOR 1UH                   |         | R548     | 1-249-941-11 | CARBON 5.6K 5%    | 1/4W    |
| L514     | 1-414-261-11 | INDUCTOR 1UH                   |         | R549     | 1-249-941-11 | CARBON 5.6K 5%    | 1/4W    |
|          |              | < TRANSISTOR >                 |         | R550     | 1-249-941-11 | CARBON 5.6K 5%    | 1/4W    |
| Q501     | 8-729-224-61 | TRANSISTOR 2SK246YGR-TPE2      |         | R551     | 1-249-941-11 | CARBON 5.6K 5%    | 1/4W    |
| Q502     | 8-729-224-61 | TRANSISTOR 2SK246YGR-TPE2      |         | R552     | 1-249-941-11 | CARBON 5.6K 5%    | 1/4W    |
| Q505     | 8-729-140-98 | TRANSISTOR 2SD773-T-34         |         | R553     | 1-249-941-11 | CARBON 5.6K 5%    | 1/4W    |
|          |              |                                |         | R554     | 1-249-941-11 | CARBON 5.6K 5%    | 1/4W    |
|          |              |                                |         | R555     | 1-249-923-11 | CARBON 1K 5%      | 1/4W    |
|          |              |                                |         | R556     | 1-249-923-11 | CARBON 1K 5%      | 1/4W    |
|          |              |                                |         | R559     | 1-249-923-11 | CARBON 1K 5%      | 1/4W    |
|          |              |                                |         | R560     | 1-249-923-11 | CARBON 1K 5%      | 1/4W    |
|          |              |                                |         | R561     | 1-216-037-00 | METAL CHIP 330 5% | 1/10W   |
|          |              |                                |         | R562     | 1-216-037-00 | METAL CHIP 330 5% | 1/10W   |
|          |              |                                |         | R563     | 1-216-037-00 | METAL CHIP 330 5% | 1/10W   |
|          |              |                                |         | R564     | 1-216-037-00 | METAL CHIP 330 5% | 1/10W   |
|          |              |                                |         | R565     | 1-216-037-00 | METAL CHIP 330 5% | 1/10W   |

| Ref. No.      | Part No.                              | Description                  | Remarks         |
|---------------|---------------------------------------|------------------------------|-----------------|
| R566          | 1-216-037-00                          | METAL CHIP                   | 330 5% 1/10W    |
| R567          | 1-216-037-00                          | METAL CHIP                   | 330 5% 1/10W    |
| R568          | 1-216-037-00                          | METAL CHIP                   | 330 5% 1/10W    |
| R577          | 1-249-520-11                          | CARBON                       | 47 5% 1/4W      |
| R578          | 1-249-520-11                          | CARBON                       | 47 5% 1/4W      |
| R581          | 1-259-452-11                          | CARBON                       | 10K 5% 1/6W     |
| R582          | 1-259-452-11                          | CARBON                       | 10K 5% 1/6W     |
| R583          | 1-259-452-11                          | CARBON                       | 10K 5% 1/6W     |
| R584          | 1-249-469-11                          | CARBON                       | 100K 5% 1/4W    |
| R585          | 1-249-469-11                          | CARBON                       | 100K 5% 1/4W    |
| R586          | 1-259-412-11                          | CARBON                       | 220 5% 1/6W     |
| R587          | 1-259-412-11                          | CARBON                       | 220 5% 1/6W     |
| R601          | 1-249-977-11                          | CARBON                       | 180K 1% 1/4W    |
| R602          | 1-249-977-11                          | CARBON                       | 180K 1% 1/4W    |
| R603          | 1-249-931-11                          | CARBON                       | 2K 5% 1/4W      |
| R604          | 1-249-931-11                          | CARBON                       | 2K 5% 1/4W      |
| R605          | 1-249-616-11                          | CARBON                       | 470K 5% 1/4W    |
| R606          | 1-249-616-11                          | CARBON                       | 470K 5% 1/4W    |
| R607          | 1-249-616-11                          | CARBON                       | 470K 5% 1/4W    |
| R608          | 1-249-616-11                          | CARBON                       | 470K 5% 1/4W    |
| R609          | 1-259-500-11                          | CARBON                       | 1M 5% 1/6W      |
| R610          | 1-259-500-11                          | CARBON                       | 1M 5% 1/6W      |
| R611          | 1-259-428-11                          | CARBON                       | 1K 5% 1/6W      |
| R612          | 1-259-428-11                          | CARBON                       | 1K 5% 1/6W      |
| < RELAY >     |                                       |                              |                 |
| RY501         | 1-515-802-11                          | RELAY                        |                 |
| < VIBRATOR >  |                                       |                              |                 |
| X501          | 1-577-686-11                          | VIBRATOR, CRYSTAL 45.1584MHZ |                 |
| *****         |                                       |                              |                 |
| A-4724-810-A  | DIG BOARD, COMPLETE (AEP,UK)<br>***** |                              |                 |
| A-4724-811-A  | DIG BOARD, COMPLETE (US,CND)<br>***** |                              |                 |
| < CAPACITOR > |                                       |                              |                 |
| C400          | 1-162-294-31                          | CERAMIC                      | 0.001uF 10% 50V |
| C401          | 1-164-159-11                          | CERAMIC                      | 0.1uF 50V       |
| C402          | 1-126-933-11                          | ELECT                        | 100uF 20% 16V   |
| C403          | 1-162-294-31                          | CERAMIC                      | 0.001uF 10% 50V |
| C404          | 1-164-159-11                          | CERAMIC                      | 0.1uF 50V       |
| C405          | 1-126-933-11                          | ELECT                        | 100uF 20% 16V   |
| C406          | 1-126-933-11                          | ELECT                        | 100uF 20% 16V   |
| C407          | 1-126-933-11                          | ELECT                        | 100uF 20% 16V   |
| C408          | 1-126-933-11                          | ELECT                        | 100uF 20% 16V   |
| C409          | 1-136-165-00                          | FILM                         | 0.1uF 5% 50V    |
| C410          | 1-136-165-00                          | FILM                         | 0.1uF 5% 50V    |
| C411          | 1-136-165-00                          | FILM                         | 0.1uF 5% 50V    |
| C412          | 1-164-159-11                          | CERAMIC                      | 0.1uF 50V       |
| C413          | 1-164-159-11                          | CERAMIC                      | 0.1uF 50V       |
| C414          | 1-164-159-11                          | CERAMIC                      | 0.1uF 50V       |
| C415          | 1-104-646-11                          | CERAMIC                      | 2.2uF 20% 50V   |
| C416          | 1-104-646-11                          | CERAMIC                      | 2.2uF 20% 50V   |
| C417          | 1-162-282-31                          | CERAMIC                      | 100PF 10% 50V   |
| C418          | 1-104-645-11                          | CERAMIC                      | 1uF 20% 50V     |
| C419          | 1-164-159-11                          | CERAMIC                      | 0.1uF 50V       |
| C421          | 1-126-176-11                          | ELECT                        | 220uF 20% 10V   |
| C422          | 1-164-159-11                          | CERAMIC                      | 0.1uF 50V       |
| C423          | 1-164-159-11                          | CERAMIC                      | 0.1uF 50V       |
| C424          | 1-124-589-11                          | ELECT                        | 47uF 20% 16V    |
| C450          | 1-164-159-11                          | CERAMIC                      | 0.1uF 50V       |

| Ref. No.       | Part No.     | Description                       | Remarks         |
|----------------|--------------|-----------------------------------|-----------------|
| C451           | 1-104-646-11 | CERAMIC                           | 2.2uF 20% 50V   |
| C453           | 1-164-159-11 | CERAMIC                           | 0.1uF 50V       |
| C454           | 1-164-159-11 | CERAMIC                           | 0.1uF 50V       |
| C455           | 1-164-159-11 | CERAMIC                           | 0.1uF 50V       |
| < DIODE >      |              |                                   |                 |
| D450           | 8-719-911-19 | DIODE 1SS133T-72                  |                 |
| < PLATE >      |              |                                   |                 |
| * EP301        | 4-870-539-00 | PLATE, GROUND                     |                 |
| * EP302        | 4-870-539-00 | PLATE, GROUND                     |                 |
| < IC >         |              |                                   |                 |
| IC401          | 8-749-012-70 | IC GP1F38R(OPT1 DIGITAL IN)       |                 |
| IC402          | 8-749-012-70 | IC GP1F38R(OPT2 DIGITAL IN)       |                 |
| IC403          | 8-749-012-69 | IC GP1F38T(OPT DIGITAL OUT)       |                 |
| IC404          | 8-759-269-92 | IC SN74HCU04ANSR                  |                 |
| IC405          | 8-759-926-17 | IC SN74HC153ANSR                  |                 |
| IC406          | 8-759-269-92 | IC SN74HCU04ANSR                  |                 |
| < JACK >       |              |                                   |                 |
| J400           | 1-784-432-11 | JACK, PIN 1P(COAXIAL DIGITAL IN)  |                 |
| J401           | 1-784-689-11 | JACK, PIN 1P(COAXIAL DIGITAL OUT) |                 |
| J450           | 1-779-655-21 | JACK (SMALL TYPE) (2 GANG)        | (CONTROL A1 II) |
| < COIL >       |              |                                   |                 |
| L400           | 1-408-599-31 | INDUCTOR 4.7uH                    |                 |
| L401           | 1-408-599-31 | INDUCTOR 4.7uH                    |                 |
| L402           | 1-408-599-31 | INDUCTOR 4.7uH                    |                 |
| L403           | 1-408-599-31 | INDUCTOR 4.7uH                    |                 |
| L404           | 1-408-599-31 | INDUCTOR 4.7uH                    |                 |
| L405           | 1-408-599-31 | INDUCTOR 4.7uH                    |                 |
| < TRANSISTOR > |              |                                   |                 |
| Q450           | 8-729-620-05 | TRANSISTOR 2SC2603TP-EF           |                 |
| < RESISTOR >   |              |                                   |                 |
| R400           | 1-247-807-31 | CARBON                            | 100 5% 1/4W     |
| R401           | 1-247-807-31 | CARBON                            | 100 5% 1/4W     |
| R402           | 1-247-807-31 | CARBON                            | 100 5% 1/4W     |
| R403           | 1-247-807-31 | CARBON                            | 100 5% 1/4W     |
| R404           | 1-247-807-31 | CARBON                            | 100 5% 1/4W     |
| R405           | 1-249-429-11 | CARBON                            | 10K 5% 1/4W     |
| R406           | 1-249-441-11 | CARBON                            | 100K 5% 1/4W    |
| R407           | 1-247-807-31 | CARBON                            | 100 5% 1/4W     |
| R408           | 1-249-429-11 | CARBON                            | 10K 5% 1/4W     |
| R409           | 1-247-903-00 | CARBON                            | 1M 5% 1/4W      |
| R410           | 1-247-807-31 | CARBON                            | 100 5% 1/4W     |
| R411           | 1-247-807-31 | CARBON                            | 100 5% 1/4W     |
| R412           | 1-247-807-31 | CARBON                            | 100 5% 1/4W     |
| R413           | 1-247-804-11 | CARBON                            | 75 5% 1/4W      |
| R414           | 1-249-409-11 | CARBON                            | 220 5% 1/4W F   |
| R415           | 1-247-804-11 | CARBON                            | 75 5% 1/4W      |
| R450           | 1-249-429-11 | CARBON                            | 10K 5% 1/4W     |
| R451           | 1-249-425-11 | CARBON                            | 4.7K 5% 1/4W F  |
| R452           | 1-249-393-11 | CARBON                            | 10 5% 1/4W F    |
| R453           | 1-247-807-31 | CARBON                            | 100 5% 1/4W     |
| R454           | 1-249-426-11 | CARBON                            | 5.6K 5% 1/4W    |

| Ref. No.                  | Part No.     | Description                   | Remarks |
|---------------------------|--------------|-------------------------------|---------|
| < TRANSFORMER >           |              |                               |         |
| T400                      | 1-416-701-11 | COIL (WITH CORE)              |         |
| *****                     |              |                               |         |
|                           | A-4724-789-A | FL BOARD, COMPLETE (AEP,UK)   |         |
|                           | A-4724-790-A | FL BOARD, COMPLETE (US,CND)   |         |
|                           | 2-389-320-01 | CUSHION                       |         |
| *                         | 3-362-478-11 | HOLDER (T), LED               |         |
| *                         | 3-362-478-11 | HOLDER (T), LED               |         |
| *                         | 4-996-686-11 | HOLDER (FL)                   |         |
| < CAPACITOR >             |              |                               |         |
| C700                      | 1-124-589-11 | ELECT 47uF 20%                | 16V     |
| C701                      | 1-124-589-11 | ELECT 47uF 20%                | 16V     |
| C765                      | 1-162-290-31 | CERAMIC 470PF 10%             | 50V     |
| C766                      | 1-162-290-31 | CERAMIC 470PF 10%             | 50V     |
| C767                      | 1-162-294-31 | CERAMIC 0.001uF 10%           | 50V     |
| C768                      | 1-162-294-31 | CERAMIC 0.001uF 10%           | 50V     |
| C770                      | 1-164-159-11 | CERAMIC 0.1MF                 | 50V     |
| C771                      | 1-162-294-31 | CERAMIC 0.001uF 10%           | 50V     |
| C772                      | 1-162-213-31 | CERAMIC 39PF 5%               | 50V     |
| C773                      | 1-162-294-31 | CERAMIC 0.001uF 10%           | 50V     |
| C774                      | 1-162-282-31 | CERAMIC 100PF 10%             | 50V     |
| C775                      | 1-162-282-31 | CERAMIC 100PF 10%             | 50V     |
| C776                      | 1-162-282-31 | CERAMIC 100PF 10%             | 50V     |
| C777                      | 1-164-159-11 | CERAMIC 0.1uF                 | 50V     |
| C778                      | 1-162-294-31 | CERAMIC 0.001uF 10%           | 50V     |
| C781                      | 1-164-159-11 | CERAMIC 0.1MF                 | 50V     |
| C782                      | 1-164-159-11 | CERAMIC 0.1MF                 | 50V     |
| < CONNECTOR >             |              |                               |         |
| CN701                     | 1-784-337-11 | CONNECTOR (FFC) 25P           |         |
| CN751                     | 1-784-642-11 | CONNECTOR, BOARD TO BOARD 11P |         |
| < LED >                   |              |                               |         |
| D753                      | 8-719-303-02 | LED SEL2510C-D-TP3(▶)         |         |
| D754                      | 8-719-301-52 | LED SEL2810A-D-TP3(■)         |         |
| D755                      | 8-719-301-39 | LED SEL2210S-D-TP3(● REC)     |         |
| < FLUORESCENT INDICATOR > |              |                               |         |
| FL781                     | 1-517-738-11 | INDICATOR TUBE, FLUORESCENT   |         |
| < IC >                    |              |                               |         |
| IC771                     | 8-759-525-49 | IC MSM9201-02GS-K             |         |
| < TRANSISTOR >            |              |                               |         |
| Q753                      | 8-729-900-80 | TRANSISTOR UN4211-TA          |         |
| Q754                      | 8-729-422-57 | TRANSISTOR UN4111-TA          |         |
| Q755                      | 8-729-422-57 | TRANSISTOR UN4111-TA          |         |
| Q781                      | 8-729-620-05 | TRANSISTOR 2SC2603TP-EF       |         |
| Q782                      | 8-729-620-05 | TRANSISTOR 2SC2603TP-EF       |         |
| < RESISTOR >              |              |                               |         |
| R702                      | 1-249-421-11 | CARBON 2.2K 5%                | 1/4W F  |
| R703                      | 1-247-843-11 | CARBON 3.3K 5%                | 1/4W    |
| R704                      | 1-249-425-11 | CARBON 4.7K 5%                | 1/4W F  |
| R705                      | 1-249-429-11 | CARBON 10K 5%                 | 1/4W    |
| R706                      | 1-249-435-11 | CARBON 33K 5%                 | 1/4W    |

| Ref. No.       | Part No.     | Description                        | Remarks |
|----------------|--------------|------------------------------------|---------|
| R712           | 1-249-421-11 | CARBON 2.2K 5%                     | 1/4W F  |
| R713           | 1-247-843-11 | CARBON 3.3K 5%                     | 1/4W    |
| R714           | 1-249-425-11 | CARBON 4.7K 5%                     | 1/4W F  |
| R717           | 1-249-429-11 | CARBON 10K 5%                      | 1/4W    |
| R718           | 1-249-435-11 | CARBON 33K 5%                      | 1/4W    |
| R753           | 1-247-807-31 | CARBON 100 5%                      | 1/4W    |
| R754           | 1-249-406-11 | CARBON 120 5%                      | 1/4W F  |
| R755           | 1-249-409-11 | CARBON 220 5%                      | 1/4W F  |
| R772           | 1-247-843-11 | CARBON 3.3K 5%                     | 1/4W    |
| R773           | 1-247-807-31 | CARBON 100 5%                      | 1/4W    |
| R774           | 1-247-807-31 | CARBON 100 5%                      | 1/4W    |
| R775           | 1-247-807-31 | CARBON 100 5%                      | 1/4W    |
| R776           | 1-247-807-31 | CARBON 100 5%                      | 1/4W    |
| R781           | 1-247-807-31 | CARBON 100 5%                      | 1/4W    |
| R782           | 1-249-441-11 | CARBON 100K 5%                     | 1/4W    |
| R783           | 1-247-807-31 | CARBON 100 5%                      | 1/4W    |
| R784           | 1-249-441-11 | CARBON 100K 5%                     | 1/4W    |
| R785           | 1-247-807-31 | CARBON 100 5%                      | 1/4W    |
| R786           | 1-247-807-31 | CARBON 100 5%                      | 1/4W    |
| < SWITCH >     |              |                                    |         |
| S701           | 1-762-875-21 | SWITCH, KEYBOARD(● REC)            |         |
| S702           | 1-762-875-21 | SWITCH, KEYBOARD(■)                |         |
| S703           | 1-762-875-21 | SWITCH, KEYBOARD(▶▶)               |         |
| S704           | 1-762-875-21 | SWITCH, KEYBOARD(◀◀)               |         |
| S705           | 1-762-875-21 | SWITCH, KEYBOARD(■)                |         |
| S706           | 1-762-875-21 | SWITCH, KEYBOARD(▶)                |         |
| S711           | 1-762-875-21 | SWITCH, KEYBOARD(MENU/NO)          |         |
| S712           | 1-762-875-21 | SWITCH, KEYBOARD(YES)              |         |
| S713           | 1-473-965-11 | ENCODER, ROTARY(AMS)               |         |
| S714           | 1-762-875-21 | SWITCH, KEYBOARD(CLEAR)            |         |
| S716           | 1-762-875-21 | SWITCH, KEYBOARD(△OPEN/CLOSE)      |         |
| S740           | 1-418-520-11 | ENCODER, ROTARY(DIGITAL REC LEVEL) |         |
| *****          |              |                                    |         |
|                | 1-674-323-11 | HP BOARD                           |         |
| *****          |              |                                    |         |
| < CAPACITOR >  |              |                                    |         |
| C651           | 1-162-207-31 | CERAMIC 22PF 5%                    | 50V     |
| C652           | 1-162-207-31 | CERAMIC 22PF 5%                    | 50V     |
| C653           | 1-126-013-11 | ELECT 1000uF 20%                   | 16V     |
| C654           | 1-126-023-11 | ELECT 100uF 20%                    | 25V     |
| C655           | 1-162-294-31 | CERAMIC 0.001uF 10%                | 50V     |
| C656           | 1-162-294-31 | CERAMIC 0.001uF 10%                | 50V     |
| C657           | 1-164-159-11 | CERAMIC 0.1uF                      | 50V     |
| C658           | 1-164-159-11 | CERAMIC 0.1uF                      | 50V     |
| < CONNECTOR >  |              |                                    |         |
| * CN651        | 1-564-709-11 | PIN, CONNECTOR (SMALL TYPE) 7P     |         |
| < IC >         |              |                                    |         |
| IC651          | 8-759-359-60 | IC NJM4556AD-D                     |         |
| < JACK >       |              |                                    |         |
| J651           | 1-770-307-11 | JACK (LARGE TYPE)(PHONES)          |         |
| < TRANSISTOR > |              |                                    |         |
| Q651           | 8-729-231-55 | TRANSISTOR 2SC2878AB-TPE2          |         |
| Q652           | 8-729-231-55 | TRANSISTOR 2SC2878AB-TPE2          |         |
| Q653           | 8-729-231-55 | TRANSISTOR 2SC2878AB-TPE2          |         |
| Q654           | 8-729-231-55 | TRANSISTOR 2SC2878AB-TPE2          |         |

|           |              |                   |           |                        |            |
|-----------|--------------|-------------------|-----------|------------------------|------------|
| <b>HP</b> | <b>MOTOR</b> | <b>OUT SWITCH</b> | <b>PJ</b> | <b>POSITION SWITCH</b> | <b>PSW</b> |
|-----------|--------------|-------------------|-----------|------------------------|------------|

| Ref. No. | Part No.     | Description                           |       |     | Remarks | Ref. No. | Part No.     | Description                    |  |  | Remarks |
|----------|--------------|---------------------------------------|-------|-----|---------|----------|--------------|--------------------------------|--|--|---------|
|          |              | < RESISTOR >                          |       |     |         | *        | 1-669-051-11 | POSITION SWITCH BOARD<br>***** |  |  |         |
| R651     | 1-259-460-11 | CARBON                                | 22K   | 5%  | 1/6W    |          |              | < CONNECTOR >                  |  |  |         |
| R652     | 1-259-460-11 | CARBON                                | 22K   | 5%  | 1/6W    |          |              |                                |  |  |         |
| R653     | 1-259-444-11 | CARBON                                | 4.7K  | 5%  | 1/6W    |          |              |                                |  |  |         |
| R654     | 1-259-458-11 | CARBON                                | 18K   | 5%  | 1/6W    |          |              |                                |  |  |         |
| R655     | 1-259-444-11 | CARBON                                | 4.7K  | 5%  | 1/6W    |          |              |                                |  |  |         |
| R656     | 1-259-458-11 | CARBON                                | 18K   | 5%  | 1/6W    |          |              |                                |  |  |         |
| R657     | 1-259-406-11 | CARBON                                | 120   | 5%  | 1/6W    |          |              |                                |  |  |         |
| R658     | 1-259-406-11 | CARBON                                | 120   | 5%  | 1/6W    |          |              |                                |  |  |         |
| R659     | 1-259-444-11 | CARBON                                | 4.7K  | 5%  | 1/6W    |          |              |                                |  |  |         |
| R660     | 1-259-444-11 | CARBON                                | 4.7K  | 5%  | 1/6W    |          |              |                                |  |  |         |
| R661     | 1-259-444-11 | CARBON                                | 4.7K  | 5%  | 1/6W    |          |              |                                |  |  |         |
| R662     | 1-259-444-11 | CARBON                                | 4.7K  | 5%  | 1/6W    |          |              |                                |  |  |         |
| R663     | 1-259-428-11 | CARBON                                | 1K    | 5%  | 1/6W    |          |              |                                |  |  |         |
| R664     | 1-259-428-11 | CARBON                                | 1K    | 5%  | 1/6W    |          |              |                                |  |  |         |
| R665     | 1-247-731-11 | CARBON                                | 22    | 5%  | 1/2W F  |          |              |                                |  |  |         |
| R666     | 1-247-727-11 | CARBON                                | 10    | 5%  | 1/2W F  |          |              |                                |  |  |         |
|          |              | < VARIABLE RESISTOR >                 |       |     |         |          |              |                                |  |  |         |
| RV651    | 1-225-492-11 | RES, VAR, CARBON 20K/20K(PHONE LEVEL) |       |     |         |          |              |                                |  |  |         |
| *****    |              |                                       |       |     |         |          |              |                                |  |  |         |
| *        | 1-669-049-11 | MOTOR BOARD<br>*****                  |       |     |         |          |              |                                |  |  |         |
|          |              | < CAPACITOR >                         |       |     |         |          |              |                                |  |  |         |
| C10      | 1-164-159-11 | CERAMIC                               | 0.1uF |     | 50V     |          |              |                                |  |  |         |
|          |              | < CONNECTOR >                         |       |     |         |          |              |                                |  |  |         |
| CN14     | 1-506-481-11 | PIN, CONNECTOR 2P                     |       |     |         |          |              |                                |  |  |         |
| *****    |              |                                       |       |     |         |          |              |                                |  |  |         |
| *        | 1-669-050-11 | OUT SWITCH BOARD<br>*****             |       |     |         |          |              |                                |  |  |         |
|          |              | < CONNECTOR >                         |       |     |         |          |              |                                |  |  |         |
| * CN10   | 1-568-951-11 | PIN, CONNECTOR 2P                     |       |     |         |          |              |                                |  |  |         |
|          |              | < SWITCH >                            |       |     |         |          |              |                                |  |  |         |
| S10      | 1-571-300-21 | SWITCH, ROTARY(PLAY POSITION)         |       |     |         |          |              |                                |  |  |         |
| *****    |              |                                       |       |     |         |          |              |                                |  |  |         |
|          | 1-674-324-11 | PJ BOARD<br>*****                     |       |     |         |          |              |                                |  |  |         |
|          |              | < CAPACITOR >                         |       |     |         |          |              |                                |  |  |         |
| C598     | 1-110-335-11 | MYLAR                                 | 100PF | 5%  | 50V     |          |              |                                |  |  |         |
| C599     | 1-110-335-11 | MYLAR                                 | 100PF | 5%  | 50V     |          |              |                                |  |  |         |
|          |              | < CONNECTOR >                         |       |     |         |          |              |                                |  |  |         |
| * CN581  | 1-564-519-11 | PLUG, CONNECTOR 4P                    |       |     |         |          |              |                                |  |  |         |
|          |              | < JACK >                              |       |     |         |          |              |                                |  |  |         |
| PJ501    | 1-568-101-11 | JACK, PIN 4P(LINE IN/OUT)             |       |     |         |          |              |                                |  |  |         |
|          |              | < RESISTOR >                          |       |     |         |          |              |                                |  |  |         |
| R591     | 1-249-504-11 | CARBON                                | 10    | 5%  | 1/4W    |          |              |                                |  |  |         |
| R592     | 1-249-504-11 | CARBON                                | 10    | 5%  | 1/4W    |          |              |                                |  |  |         |
| R593     | 1-249-528-91 | CARBON                                | 100   | 5%  | 1/4W    |          |              |                                |  |  |         |
| R594     | 1-249-528-91 | CARBON                                | 100   | 5%  | 1/4W    |          |              |                                |  |  |         |
| *****    |              |                                       |       |     |         |          |              |                                |  |  |         |
|          |              | < CAPACITOR >                         |       |     |         |          |              |                                |  |  |         |
| C761     | 1-124-589-11 | ELECT                                 | 47uF  | 20% | 16V     |          |              |                                |  |  |         |
| C762     | 1-164-159-11 | CERAMIC                               | 0.1uF |     | 50V     |          |              |                                |  |  |         |
|          |              | < CONNECTOR >                         |       |     |         |          |              |                                |  |  |         |
| CN750    | 1-784-641-11 | CONNECTOR, BOARD TO BOARD 11P         |       |     |         |          |              |                                |  |  |         |
|          |              | < LED >                               |       |     |         |          |              |                                |  |  |         |
| D756     | 8-719-046-46 | LED SEL5221S-TH8F(STANDBY)            |       |     |         |          |              |                                |  |  |         |
| D757     | 8-719-303-02 | LED SEL2510C-D-TP3(FILTER)            |       |     |         |          |              |                                |  |  |         |
| D758     | 8-719-301-52 | LED SEL2810A-D-TP3(PITCH CONTROL)     |       |     |         |          |              |                                |  |  |         |
|          |              | < IC >                                |       |     |         |          |              |                                |  |  |         |
| IC761    | 8-749-013-92 | IC GP1UC7X(REMOTE SENSOR)             |       |     |         |          |              |                                |  |  |         |
|          |              | < TRANSISTOR >                        |       |     |         |          |              |                                |  |  |         |
| Q756     | 8-729-900-80 | TRANSISTOR UN4211-TA                  |       |     |         |          |              |                                |  |  |         |
| Q757     | 8-729-900-80 | TRANSISTOR UN4211-TA                  |       |     |         |          |              |                                |  |  |         |
| Q758     | 8-729-900-80 | TRANSISTOR UN4211-TA                  |       |     |         |          |              |                                |  |  |         |
|          |              | < RESISTOR >                          |       |     |         |          |              |                                |  |  |         |
| R722     | 1-249-421-11 | CARBON                                | 2.2K  | 5%  | 1/4W F  |          |              |                                |  |  |         |
| R723     | 1-247-843-11 | CARBON                                | 3.3K  | 5%  | 1/4W    |          |              |                                |  |  |         |
| R724     | 1-249-425-11 | CARBON                                | 4.7K  | 5%  | 1/4W F  |          |              |                                |  |  |         |
| R725     | 1-249-429-11 | CARBON                                | 10K   | 5%  | 1/4W    |          |              |                                |  |  |         |
| R726     | 1-249-435-11 | CARBON                                | 33K   | 5%  | 1/4W    |          |              |                                |  |  |         |
| R732     | 1-249-421-11 | CARBON                                | 2.2K  | 5%  | 1/4W F  |          |              |                                |  |  |         |
| R733     | 1-247-843-11 | CARBON                                | 3.3K  | 5%  | 1/4W    |          |              |                                |  |  |         |
| R734     | 1-249-425-11 | CARBON                                | 4.7K  | 5%  | 1/4W F  |          |              |                                |  |  |         |
| R742     | 1-249-426-11 | CARBON                                | 5.6K  | 5%  | 1/4W    |          |              |                                |  |  |         |
| R743     | 1-249-425-11 | CARBON                                | 4.7K  | 5%  | 1/4W F  |          |              |                                |  |  |         |
| R744     | 1-249-429-11 | CARBON                                | 10K   | 5%  | 1/4W    |          |              |                                |  |  |         |
| R745     | 1-249-435-11 | CARBON                                | 33K   | 5%  | 1/4W    |          |              |                                |  |  |         |
| R751     | 1-249-429-11 | CARBON                                | 10K   | 5%  | 1/4W    |          |              |                                |  |  |         |
| R752     | 1-249-429-11 | CARBON                                | 10K   | 5%  | 1/4W    |          |              |                                |  |  |         |
| R756     | 1-249-409-11 | CARBON                                | 220   | 5%  | 1/4W F  |          |              |                                |  |  |         |
| R757     | 1-249-403-11 | CARBON                                | 68    | 5%  | 1/4W F  |          |              |                                |  |  |         |
| R758     | 1-249-402-11 | CARBON                                | 56    | 5%  | 1/4W F  |          |              |                                |  |  |         |
| R761     | 1-249-401-11 | CARBON                                | 47    | 5%  | 1/4W F  |          |              |                                |  |  |         |
| R762     | 1-247-807-31 | CARBON                                | 100   | 5%  | 1/4W    |          |              |                                |  |  |         |
| R787     | 1-247-807-31 | CARBON                                | 100   | 5%  | 1/4W    |          |              |                                |  |  |         |

| Ref. No.       | Part No.                    | Description                      | Remarks |
|----------------|-----------------------------|----------------------------------|---------|
| R788           | 1-247-807-31                | CARBON 100 5%                    | 1/4W    |
| R789           | 1-247-807-31                | CARBON 100 5%                    | 1/4W    |
| < SWITCH >     |                             |                                  |         |
| S722           | 1-762-875-21                | SWITCH, KEYBOARD(PLAY MODE)      |         |
| S723           | 1-762-875-21                | SWITCH, KEYBOARD(REPEAT)         |         |
| S724           | 1-762-875-21                | SWITCH, KEYBOARD(SCROLL)         |         |
| S725           | 1-762-875-21                | SWITCH, KEYBOARD(DISPLAY/CHAR)   |         |
| S726           | 1-762-875-21                | SWITCH, KEYBOARD(I/O)            |         |
| S731           | 1-762-875-21                | SWITCH, KEYBOARD(TIME)           |         |
| S732           | 1-762-875-21                | SWITCH, KEYBOARD(FADER)          |         |
| S733           | 1-570-101-51                | SWITCH, KEY BOARD(FILTER)        |         |
| S734           | 1-570-101-21                | SWITCH, KEY BOARD(PITCH CONTROL) |         |
| S741           | 1-771-171-11                | SWITCH, ROTARY(INPUT)            |         |
| S751           | 1-572-625-11                | SWITCH, SLIDE(TIMER)             |         |
| *****          |                             |                                  |         |
| A-4724-804-A   | PW BOARD, COMPLETE (AEP,UK) |                                  |         |
| *****          |                             |                                  |         |
| A-4724-805-A   | PW BOARD, COMPLETE (US,CND) |                                  |         |
| *****          |                             |                                  |         |
| * 4-363-146-71 | HEAT SINK, V.OUT            |                                  |         |
| * 4-941-237-11 | HEAT SINK                   |                                  |         |
| 7-685-646-79   | SCREW +BVTP 3 x 8 TYPE2 N-S |                                  |         |
| < CAPACITOR >  |                             |                                  |         |
| C201           | 1-117-850-11                | ELECT 15000MF 20%                | 16V     |
| C202           | 1-164-159-11                | CERAMIC 0.1uF                    | 50V     |
| C203           | 1-126-939-11                | ELECT 10000uF 20%                | 16V     |
| C204           | 1-127-941-11                | ELECT 6800uF 20%                 | 63V     |
| C205           | 1-127-941-11                | ELECT 6800uF 20%                 | 63V     |
| C206           | 1-164-159-11                | CERAMIC 0.1uF                    | 50V     |
| C207           | 1-164-159-11                | CERAMIC 0.1uF                    | 50V     |
| C208           | 1-164-159-11                | CERAMIC 0.1uF                    | 50V     |
| C209           | 1-164-159-11                | CERAMIC 0.1uF                    | 50V     |
| C210           | 1-164-159-11                | CERAMIC 0.1uF                    | 50V     |
| C213           | 1-136-153-00                | FILM 0.01uF 5%                   | 50V     |
| C214           | 1-136-153-00                | FILM 0.01uF 5%                   | 50V     |
| C217           | 1-126-935-11                | ELECT 470uF 20%                  | 16V     |
| C218           | 1-164-159-11                | CERAMIC 0.1uF                    | 50V     |
| C231           | 1-117-149-21                | ELECT 2200uF 20%                 | 25V     |
| C232           | 1-126-942-61                | ELECT 1000uF 20%                 | 25V     |
| C233           | 1-164-732-11                | CERAMIC 0.1uF 20%                | 50V     |
| C234           | 1-164-732-11                | CERAMIC 0.1uF 20%                | 50V     |
| C235           | 1-164-732-11                | CERAMIC 0.1uF 20%                | 50V     |
| C236           | 1-164-732-11                | CERAMIC 0.1uF 20%                | 50V     |
| C241           | 1-104-663-11                | ELECT 33uF 20%                   | 25V     |
| C242           | 1-126-963-11                | ELECT 4.7uF 20%                  | 50V     |
| C243           | 1-126-964-11                | ELECT 10uF 20%                   | 50V     |
| C244           | 1-164-159-11                | CERAMIC 0.1uF                    | 50V     |
| C245           | 1-126-916-11                | ELECT 1000uF 20%                 | 6.3V    |
| C246           | 1-126-925-11                | ELECT 470uF 20%                  | 10V     |
| C247           | 1-164-159-11                | CERAMIC 0.1uF                    | 50V     |
| C248           | 1-164-159-11                | CERAMIC 0.1uF                    | 50V     |
| C251           | 1-126-965-11                | ELECT 22uF 20%                   | 50V     |
| C252           | 1-164-159-11                | CERAMIC 0.1uF                    | 50V     |
| C253           | 1-126-933-11                | ELECT 100uF 20%                  | 16V     |
| C254           | 1-162-306-11                | CERAMIC 0.01uF 30%               | 16V     |
| C255           | 1-162-306-11                | CERAMIC 0.01uF 30%               | 16V     |
| C261           | 1-164-159-11                | CERAMIC 0.1uF                    | 50V     |
| C262           | 1-164-159-11                | CERAMIC 0.1uF                    | 50V     |

| Ref. No.      | Part No.     | Description                                 | Remarks |
|---------------|--------------|---|---------|
| C263          | 1-126-916-11 | ELECT 1000uF 20%                            | 6.3     |
| C271          | 1-107-935-11 | ELECT 330uF 20%                             | 100     |
| C272          | 1-164-159-11 | CERAMIC 0.1uF                               | 50V     |
| C273          | 1-126-969-11 | ELECT 220uF 20%                             | 50V     |
| C283          | 1-126-022-11 | ELECT 47uF 20%                              | 25V     |
| C284          | 1-164-159-11 | CERAMIC 0.1uF                               | 50V     |
| C285          | 1-164-159-11 | CERAMIC 0.1uF                               | 50V     |
| < CONNECTOR > |              |   |         |
| CN201         | 1-779-289-11 | CONNECTOR,FFC(LIF(NON-ZIF))21P              |         |
| * CN202       | 1-564-709-11 | PIN, CONNECTOR (SMALL TYPE) 7P              |         |
| CN205         | 1-691-769-11 | PLUG (MICRO CONNECTOR) 7P                   |         |
| CN207         | 1-691-769-11 | PLUG (MICRO CONNECTOR) 7P                   |         |
| CN208         | 1-779-281-11 | CONNECTOR,FFC(LIF(NON-ZIF))13P              |         |
| < DIODE >     |              |   |         |
| D201          | 8-719-210-29 | DIODE F10P10Q                               |         |
| D202          | 8-719-210-29 | DIODE F10P10Q                               |         |
| D203          | 8-719-200-77 | DIODE 10E2N-TA2B                            |         |
| D204          | 8-719-210-29 | DIODE F10P10Q                               |         |
| D205          | 8-719-210-29 | DIODE F10P10Q                               |         |
| D206          | 8-719-210-29 | DIODE F10P10Q                               |         |
| D207          | 8-719-210-29 | DIODE F10P10Q                               |         |
| D208          | 8-719-200-77 | DIODE 10E2N-TA2B                            |         |
| D210          | 8-719-911-19 | DIODE 1SS133T-72                            |         |
| D211          | 8-719-911-19 | DIODE 1SS133T-72                            |         |
| D212          | 8-719-983-62 | DIODE MTZJ-T-72-3.3A                        |         |
| D213          | 8-719-911-19 | DIODE 1SS133T-72                            |         |
| D231          | 8-719-210-21 | DIODE 11EQS04-TA2B                          |         |
| D232          | 8-719-210-21 | DIODE 11EQS04-TA2B                          |         |
| D241          | 8-719-200-82 | DIODE 11ES2-TA2B                            |         |
| D242          | 8-719-200-82 | DIODE 11ES2-TA2B                            |         |
| D243          | 8-719-911-19 | DIODE 1SS133T-72                            |         |
| D251          | 8-719-933-39 | DIODE HZS6C1LTA                             |         |
| D705          | 8-719-160-26 | DIODE HZ5.6BP-TK                            |         |
| D706          | 8-719-200-77 | DIODE 10E2N-TA2B                            |         |
| < PLATE >     |              |   |         |
| * EP200       | 4-870-539-00 | PLATE, GROUND                               |         |
| * EP201       | 4-870-539-00 | PLATE, GROUND                               |         |
| < FUSE >      |              |   |         |
| △ F201        | 1-532-776-21 | FUSE, MICRO (SECONDARY) 1A 125V(US,CND)     |         |
| △ F202        | 1-532-781-21 | FUSE, MICRO (SECONDARY) 3.15A 125V (US,CND) |         |
| △ F203        | 1-532-781-21 | FUSE, MICRO (SECONDARY) 3.15A 125V (US,CND) |         |
| < IC >        |              |   |         |
| IC230         | 8-759-604-39 | IC M5F78M12L                                |         |
| IC231         | 8-759-604-45 | IC M5F79M12L                                |         |
| IC240         | 8-759-525-48 | IC LA5632                                   |         |
| IC250         | 8-759-822-09 | IC LB1641                                   |         |
| IC260         | 8-759-513-71 | IC PQ05RF21                                 |         |
| IC270         | 8-759-633-42 | IC M5293L                                   |         |
| < IC LINK >   |              |   |         |
| △ ICP201      | 1-532-839-11 | IC LINK 1A 125V(AEP,UK)                     |         |
| △ ICP202      | 1-532-844-21 | IC LINK 3.15A 125V(AEP,UK)                  |         |
| △ ICP203      | 1-532-844-21 | IC LINK 3.15A 125V(AEP,UK)                  |         |

| Ref. No. | Part No.     | Description                | Remarks | Ref. No. | Part No.     | Description                                    | Remarks |
|----------|--------------|----------------------------|---------|----------|--------------|--|---------|
|          |              | < TRANSISTOR >             |         |          |              | MISCELLANEOUS<br>*****                         |         |
| Q201     | 8-729-140-98 | TRANSISTOR 2SD773-T-34     |         | 72       | 1-791-547-11 | WIRE (FLAT TYPE) (25 CORE)                     |         |
| Q202     | 8-729-902-80 | TRANSISTOR UN4114-TA       |         | 108      | 1-790-202-11 | WIRE (FLAT TYPE) (23 CORE)                     |         |
| Q203     | 8-729-902-80 | TRANSISTOR UN4114-TA       |         | △ 109    | 1-558-568-21 | CORD, POWER(AEP)                               |         |
| Q204     | 8-729-140-98 | TRANSISTOR 2SD773-T-34     |         | △ 109    | 1-559-583-21 | CORD, POWER(US,CND)                            |         |
| Q251     | 8-729-119-76 | TRANSISTOR 2SA1115TP-EF    |         | △ 109    | 1-696-586-11 | CORD, POWER(UK)                                |         |
| Q252     | 8-729-900-80 | TRANSISTOR UN4211-TA       |         | 114      | 1-791-166-11 | WIRE (FLAT TYPE) (21 CORE)                     |         |
|          |              | < RESISTOR >               |         | 121      | 1-790-205-11 | WIRE (FLAT TYPE) (17 CORE)                     |         |
| R201     | 1-249-437-11 | CARBON 47K 5% 1/4W         |         | 122      | 1-791-168-11 | WIRE (FLAT TYPE) (27 CORE)                     |         |
| R202     | 1-249-425-11 | CARBON 4.7K 5% 1/4W F      |         | 123      | 1-791-167-11 | WIRE (FLAT TYPE) (13 CORE)                     |         |
| R203     | 1-247-807-31 | CARBON 100 5% 1/4W         |         | 251      | 1-667-954-11 | PC BOARD, FLEXIBLE                             |         |
| R204     | 1-249-429-11 | CARBON 10K 5% 1/4W         |         | △ 259    | A-4672-541-A | OPTICAL PICK-UP KMS-260B/J1N                   |         |
| R205     | 1-247-807-31 | CARBON 100 5% 1/4W         |         | HR901    | 1-500-565-11 | HEAD, OVER LIGHT                               |         |
| R206     | 1-249-429-11 | CARBON 10K 5% 1/4W         |         | M10      | X-4949-791-1 | MOTOR (LOADING) ASSY                           |         |
| R207     | 1-249-437-11 | CARBON 47K 5% 1/4W         |         | M101     | A-4672-475-A | MOTOR ASSY, SPINDLE                            |         |
| R208     | 1-249-425-11 | CARBON 4.7K 5% 1/4W F      |         | M102     | A-4672-474-A | MOTOR ASSY, SLED                               |         |
| R241     | 1-247-807-31 | CARBON 100 5% 1/4W         |         | S102     | 1-762-148-21 | SWITCH, PUSH (2 KEY)<br>(REFLECT/PROTECT DET.) |         |
| R242     | 1-249-412-11 | CARBON 390 5% 1/4W F       |         | △ T001   | 1-433-987-11 | TRANSFORMER, POWER(US,CND)                     |         |
| R243     | 1-249-417-11 | CARBON 1K 5% 1/4W F        |         | △ T001   | 1-433-989-11 | TRANSFORMER, POWER(UK,AEP)                     |         |
| R244     | 1-249-429-11 | CARBON 10K 5% 1/4W         |         | △ T002   | 1-433-988-11 | TRANSFORMER, POWER(US,CND)                     |         |
| R245     | 1-249-433-11 | CARBON 22K 5% 1/4W         |         | △ T002   | 1-433-990-11 | TRANSFORMER, POWER(UK,AEP)                     |         |
| R251     | 1-249-417-11 | CARBON 1K 5% 1/4W F        |         |          |              | ACCESSORIES & PACKING MATERIALS<br>*****       |         |
| R252     | 1-249-433-11 | CARBON 22K 5% 1/4W         |         |          |              |  |         |
| R253     | 1-249-429-11 | CARBON 10K 5% 1/4W         |         |          |              |  |         |
| R254     | 1-249-429-11 | CARBON 10K 5% 1/4W         |         |          |              |  |         |
| R271     | 1-247-807-31 | CARBON 100 5% 1/4W         |         |          |              |  |         |
| R272     | 1-247-843-11 | CARBON 3.3K 5% 1/4W        |         |          |              |  |         |
| R273     | 1-249-434-11 | CARBON 27K 5% 1/4W         |         |          |              |  |         |
| R281     | 1-249-417-11 | CARBON 1K 5% 1/4W F        |         |          |              |  |         |
|          |              | < RELAY >                  |         |          |              |  |         |
| RY200    | 1-515-925-11 | RELAY                      |         |          |              |  |         |
| RY201    | 1-515-925-11 | RELAY                      |         |          |              |  |         |
| *****    |              |                            |         |          |              |  |         |
|          | 1-674-328-11 | REC BOARD<br>*****         |         |          |              |  |         |
|          |              | < CONNECTOR >              |         |          |              |  |         |
| CN760    | 1-564-511-11 | PLUG, CONNECTOR 8P         |         |          |              |  |         |
|          |              | < RESISTOR >               |         |          |              |  |         |
| R765     | 1-249-955-11 | CARBON 22K 5% 1/4W         |         |          |              |  |         |
| R766     | 1-249-955-11 | CARBON 22K 5% 1/4W         |         |          |              |  |         |
|          |              | < VARIABLE RESISTOR >      |         |          |              |  |         |
| RV760    | 1-225-883-11 | RES, VAR(ANALOG REC LEVEL) |         |          |              |  |         |
| *****    |              |                            |         |          |              |  |         |

|  |  |
|--|--|
| The components identified by mark △ or dotted line with mark △ are critical for safety. Replace only with part number specified. | Les composants identifiés par une marque △ sont critiques pour la sécurité. Ne les remplacer que par une pièce portant le numéro spécifié. |
|--|--|

